

of the University  
of Pardubice  
**Faculty of Economics  
and Administration**



**SCIENTIFIC PAPERS OF THE UNIVERSITY OF PARDUBICE**

**Series D**

**Faculty of Economics and Administration**

**No. 24 (2/2012)**

**Vol. XVIII**

# **SCIENTIFIC PAPERS OF THE UNIVERSITY OF PARDUBICE**

**Series D**

**Faculty of Economics and Administration**

**No. 24 (2/2012)**

**Vol. XVIII**

Registration MK ČR E 19548

ISSN 1211-555X (Print)

ISSN 1804-8048 (Online)

Contribution in the journal have been reviewed and approved by the editorial board.  
Contributions are not edited.

© University of Pardubice, 2012

## **ABOUT JOURNAL**

Scientific Papers of the University of Pardubice, Series D journal aims to be an open platform for publication of innovative results of theoretical, applied and empirical research across a broad range of disciplines such as economics, management, finance, social sciences, law, computer sciences and system engineering with the intention of publishing research results, primarily academics and students of doctoral study programmes in the Czech Republic and abroad.

The journal is published every year since 1996 and papers are submitted to review. The paper is included in the List of reviewed non-impacted periodicals published in the Czech Republic, it is also monitored by EBSCO Publishing and ProQuest and it is published 3x per year.

## **CONTENTS**

<b>APPLOVÁ, P.: A NEW PROCEDURE TO DEAL WITH THE MACROECONOMIC IMBALANCE IN THE EUROPEAN UNION</b> .....	5
<b>CENEK, J.: EVALUATION OF TRANSIT LINES PLAN</b> .....	14
<b>ČAPEK, J.: CLOUD COMPUTING AND INFORMATION SECURITY</b> .....	23
<b>ČERVINKA, M., TYKVA, T.: THE RELATION BETWEEN AIR TRANSPORT AND SELECTED ASPECTS OF THE REGIONAL ECONOMY</b> .....	31
<b>ČÍŽEK, P.: THE APPLICATION OF MASLOW'S HIEARCHY OF NEEDS TO THE ENTREPRENEUR'S MOTIVATION – THE EXAMPLE FROM REGION PARDUBICE</b> .....	43
<b>GARGULÁKOVÁ, M., BELÁS, J.: BANK STRESS TESTS, FINANCIAL STABILITY AND SIMULATION OF "FEEDBACK" EFFECT</b> .....	51
<b>GLETA, J., TEPLÝ, P.: AN INSTITUTIONAL ANALYSIS OF BANK REGULATION</b> .....	64
<b>HONKOVÁ, I.: FINANCIAL HEALTH AND THE COST OF CAPITAL OF TRAVEL AGENCIES BEFORE AND AFTER THE CRISIS</b> .....	77
<b>JONÁŠOVÁ, H., MICHÁLEK, K., PANUŠ, J.: USING CLUSTER ANALYSIS FOR THE STUDY OF GENERATION Y BEHAVIOR AT THE UNIVERSITY OF PARDUBICE</b> .....	90
<b>KOŽÁTKOVÁ STRÁNSKÁ, P., LELEK, T.: ANALYSIS OF EUROPEAN UNION COHESION</b> .....	102
<b>MANDYSOVÁ, I.: CREATING A CONTEXT AS THE BASE FOR ENTREPRENEURIAL SUPPORT POLICY</b> .....	114
<b>MELUZÍN, T., DOUBRAVSKÝ, K., DOHNAL, M.: DECISION-MAKING ON IPO IMPLEMENTATION UNDER CONDITIONS OF UNCERTAINTY</b> .....	124

<b>POÓR, J., VOLOŠIN, M., ENGLE, A., MACHOVÁ, R., KAROLINY, M.: HUMAN RESOURCE MANAGEMENT UNDER CHANGES AT FOREIGN SUBSIDIARIES IN SLOVAKIA IN LIGHT OF REGIONAL COMPARISON .....</b>	<b>137</b>
<b>POPRAWSKA, E., JEDRZYCHOWSKA, A.: SELECTED PROBLEMS ASSOCIATED WITH MODELING THE BIGGEST COMPENSATIONS IN NON-LIFE INSURANCE .....</b>	<b>152</b>
<b>SOBOTKA, M., SOBOTKOVÁ, L., ŘÍZEK, Z.: THE POTENTIAL OF ENLARGEMENT OF THE EUROPEAN UNION .....</b>	<b>161</b>
<b>SVEDAITE, E., TAMOSIUNAS, T.: TEMPORARY EMPLOYMENT AS AN ALTERNATIVE UNEMPLOYEMENT RATE REDUCING NEW EMPLOYMENT FORM ANALYSIS IN LITHUANIA AND CZECH REPUBLIC .....</b>	<b>174</b>
<b>SZAROWSKÁ, I.: THE CYCLICALITY OF GOVERNMENT EXPENDITURE AND WAGNER'S LAW – CASE OF CZECH REPUBLIC, SLOVAKIA, HUNGARY, BULGARIA AND ROMANIA .....</b>	<b>188</b>
<b>TICHÝ, O.: INFORMATION AND COMMUNICATION TECHNOLOGIES AND THEIR BENEFITS FOR MEDIUM AND LARGE-SIZED ENTERPRISES.....</b>	<b>199</b>
<b>URBANCOVÁ, H., KRŽÍŽ, J.: IMPROVING THE QUALITY OF PROCESSES BY USING KNOWLEDGE CONTINUITY ENSURING .....</b>	<b>212</b>
<b>Guidelines for paper writing .....</b>	<b>224</b>

# A NEW PROCEDURE TO DEAL WITH THE MACROECONOMIC IMBALANCE IN THE EUROPEAN UNION

Petra Applová

***Abstract:** The objective of the presented paper is, in the first place, to look into the solution of current serious macroeconomic problems of member states of the European Union by laying down a new enforcement mechanism described in the Alert Mechanism Report (AMR). In recent years distinctive and persistent macroeconomic imbalances have accumulated that are reflected in high and persistent external deficits and surpluses, in the persistent loss of competitiveness, in the dramatic increase in indebtedness and in the increase in real estate bubbles, which were one of the causes of the current financial crisis. Macroeconomic problems of the European Union's economies are dealt with in the very AMR, which defines a new procedure for the prevention and reformation of macroeconomic dysfunctions. Based on compliance with ten selected indicators according to determined threshold values those economies are identified that are liable to undergoing various macroeconomic imbalances in years to come. In the end the paper uses selected statistic methods, namely cluster analysis, to look into the mentioned indicators of external imbalances and competitiveness and imbalances inside an economy in question. The article focuses on the analysis of the created clusters according to their similarity in the development of the mentioned macroeconomic indicators and on the assessment of the conclusions of the EU commission.*

***Keywords:** Macroeconomic imbalances, Internal imbalances, External imbalances, Excessive Imbalance Procedure, Alert Mechanism Report.*

***JEL Classification:** E6, H6.*

## Introduction

In general it is true that the condition for long-term sustainability of the growth of the economy's performance is the mutual bond between the internal and external balance, i.e. the macroeconomic stability. The objectives of the related stabilisation policies for current EU members as well as candidate countries are predetermined by the terms and conditions for the membership in the Economic and Monetary Union (EMU). The internal balance is characterised especially by the price and fiscal stability and moreover by the quality of the domestic financial sector. The internal stability is also the condition for the domestic economy's resistance to external shocks and for the sustainability of the external balance characterised by the balance of the current account [7].

At the moment the economies of the EU are facing serious macroeconomic problems that are demonstrated, besides other things, by the dramatic increase

in the overall indebtedness of the economies in question, by increasing unemployment or by a long-term loss of competitiveness.

The paper sets the objective to describe the new and, to a large extent, revolutionary procedure of the EU for the dealing with the macroeconomic imbalance, the so-called Excessive Imbalance Procedure, the crucial part of which is the Alert Mechanism Report, including the main findings of this report. Subsequently, in the end of the paper, the indicators of external imbalances and competitiveness and of the internal imbalances are analysed on the basis of the selected statistical method with the objective to assess the conclusions of the EU's Commission.

The importance of the procedure lies mainly in the implementation of a new surveillance method for the prevention and reformation of macroeconomic imbalances, which makes the procedure a new tool of the extended framework for the administration of the EU's economic issues. The extended surveillance has been adopted in the form of a package of "six legal acts" concerning the administration of economic issues, which determines, among other things, a significant extension of the surveillance over fiscal policies. The surveillance over macroeconomic imbalances forms a self-contained measure for the monitoring of the economic policy's problem that the EU encounters in the course of the providing for fiscal sustainability, competitiveness, the stability of the financial market and the economic growth, and estimates their future development [3].

## **1 The new surveillance procedure for prevention and reformation of macroeconomic imbalances**

The systematic financial crisis, which broke out in 2008, manifested the insufficient attention that had been paid to macroeconomic imbalances and other displays of divergence within the EMU. Lenience towards a disregard in respect to frequent recommendations that have been continuously directed at member countries within the framework of regular multilateral surveillance has proved itself to be wrong. Thus this experience has shown that this surveillance has to be supported with a suitable enforcement mechanism, if it is to be effective.

### **1.1 The Excessive Imbalance Procedure and the Alert Mechanism Report**

In December 2011 the so-called Excessive Imbalance Procedure (EIP) became effective. The starting point of this procedure is the so-called Alert Mechanism Report (AMR) that is compiled by the EU Commission on the basis of consultations with the European Parliament, the European Council and the European Systemic Risk Board.

The objective of this new enforcement mechanism is to identify those member countries that could be facing problems due to various imbalances. For this purpose a scoreboard is compiled that is composed of ten indicators that focus on the area of external imbalances and competitiveness and on the sphere of internal imbalances. For each of these indicators informative threshold values have been set, however these are not defined in a rigid manner in order to be able to highlight existing problems. A detailed description of individual indicators, including selected periods for the calculation of the informative threshold values, is provided in Table 1. The Commission uses these indicators to identify those EU countries that, due to their

macroeconomic development, require in-depth analysis and subsequently recommends suitable policies to concerned economies that form the preventive or reformatory part of the task.

**Tab. 1: Envisaged indicators and indicative thresholds**

<b>External imbalances and competitiveness</b>					
Indicator	3 year average of <b>current account balance</b> as a % of GDP	Net International Investment Position as a % of GDP	<b>% change (3 years) of Real Effective Exchange Rate, HICP deflators</b> relative to 35 industrial countries <sup>a)</sup>	% change (5 years) in <b>export market shares</b>	% change (3 years) in <b>nominal unit labour cost</b> <sup>b)</sup>
Indicative thresholds	+6/-4% GDP	-35% Lower quartile	+/-5% for €A +/-11% non €A Lower and Upper Quartiles of EA - /+ s. d. of EA	-6% Lower quartile	+9% €A +12% non-€A Upper quartile €A3 p-p
Period for calculating thresholds	1970 – 2007	First available year (mid-1990s)-2007	1995 – 2007	1995 – 2007	1995 – 2007
<b>Internal imbalances</b>					
Indicator	<b>y-o-y % change in deflated house prices</b> <sup>c)</sup>	Private sector credit flow as % of GDP <sup>d), e)</sup>	Private sector debt as % of GDP <sup>d), e)</sup>	General government debt as % of GDP	<b>3 year average of unemployment rate</b>
Indicative thresholds	+6% Upper quartile	+15% Upper quartile	160% Upper quartile	+60% GDP	+10%
Period for calculating thresholds		1995 – 2007	1994 – 2007		1994 – 2007

Source: [3]; [9].

(a) for EU trading partners HICP is used while for non-EU trading partners, the deflator is based on a CPI close to the HICP in methodology; (b) index providing ratio of nominal compensation per employee to real GDP per person employed; (c) changes in house prices relative to the consumption deflator of EUROSTAT; (d) private sector is defined as non-financial corporations; households and non-profit institutions serving households; (e) sum of Loans, and Securities other than shares; liabilities, non-consolidated; (f) the sustainability of public finances will *not* be assessed in the context



of the EIP given that this issue is already covered by the SGP. However this indicator is part of the scoreboard because public indebtedness contributes to total indebtedness of the country and therefore to the overall vulnerability of the country.

The primary sustainability of public finances is assessed and subsequently dealt with by the Stability and Growth Pact. Still the fiscal imbalance indicator, expressed as the amount of the public debt in proportion to the GDP (in %), is quite rightly included in the scoreboard. The fiscal imbalance of given economies contributes to the overall indebtedness, which has impact on the entire macroeconomic balance. The long-term fiscal imbalance is an insidious phenomenon, because the anonymity of concrete causes of its emergence represents an enormous economic problem with serious not only budgetary, but especially macroeconomic consequences. We should not forget that even though good budgetary discipline belongs among convergence criteria, the fiscal policy is still in the hands of national governments, unlike the monetary policy that is secured by the European Central Bank after a country enters the euro area. The argument for the definition of these convergence criteria was a significantly differing development of macroeconomic figures in individual member states and therefore the opinion that some countries are not sufficiently prepared to meet the requirements of the necessary monetary and fiscal policy was prevailing. At the moment the convergence criteria have come under “expert criticism” because they were determined on the political rather than economic basis, as the development of most economies of the entire EU has shown. The point of these criteria was to ensure that only stabilised countries would become members of the unified monetary union so that the compactness and stability of the euro area would not be threatened – however the rigidity of these criteria and a certain relaxed spirit in meeting them were among the factors that have contributed the today’s economic situation in Europe.

The mentioned indicators of macroeconomic balance of the EU’s member countries are assessed on the basis of the continuous development, including the predicted development and other relevant indicators.

Besides the named ten indicators, the Commission also pays special attention to an extended set of indicators, which also include nominal and real convergence inside and outside of the EMU as well as the commercial performance and the productivity of labour.<sup>1</sup>

## **1.2 Conclusions identified by the AMR**

The historically first data concerning the mentioned macroeconomic balance, or imbalance as the case may be, of the EU member countries for the year of 2010 were presented by the European Commission on 14<sup>th</sup> February 2012.<sup>2</sup>

Based on the executed thorough analyses, the Commission had arrived at the conclusion that in some member countries of the EU it would be necessary to carry out a more detailed evaluation of the risk of microeconomic imbalances because these countries were facing various problems and potential risks. The countries concerned

---

<sup>1</sup> In detail [7].

<sup>2</sup> Data in [7].

were Belgium, Bulgaria, Denmark, Finland, France, Italy, Cyprus, Hungary, Germany, Slovenia, Spain, Sweden and the United Kingdom.

The AMR also provides some surprising information about our economy. Even though the public finances, as one of the important components of the macroeconomic balance, are not considered sustainable from the long-term viewpoint, the Commission is of the opinion that they do not need to be analysed in detail at the moment. Besides the Czech Republic this finding also applies for Estonia, Lithuania, Latvia, Luxemburg, Malta, the Netherlands, Poland, Austria and Slovakia.

It should be pointed out that the AMR does not deal with countries with which a financial aid program has been concluded, i.e. Ireland, Portugal, Romania and Greece, since the mentioned surveillance is already being carried out in these countries.

The EIP takes place according to the procedure defined in advance. After the consultation of the AMR in the Euro Group and in the Informal Economic and Financial Affairs Council (ECOFIN) the Commission will execute extensive analyses of the “selected” countries. If the economic situation of a country “selected” in this way is evaluated as non-problematic the Commission will not take any other further measures, i.e. the procedure will be completed. However if the Commission arrives at the conclusion that there are minor macroeconomic imbalances in such country, the country will receive recommendations aiming to correct or prevent identified imbalances. The last alternative that may occur is that the Commission will declare that there are major imbalances in a country in question that threaten the proper functioning of the EMU. Subsequently the Commission will recommend to the Council that it should start the EIP. If this proposal is approved the concerned country will have to present an action plan for the reformation of imbalances that has to contain clearly formulated measures and concrete deadlines for their implementation. This country will be under the Commission’s extended surveillance and will be obliged to prepare regular reports about the progress of imbalances elimination.

The EIP also contains the option to impose sanctions for the non-fulfilment of prescribed obligations; however this applies only for member countries of the euro area [5].

## **2 Statistic analyses of the data of the AMR set of criteria concerning the EU’s member countries for 2010**

A detailed study of the table of the resulting values of the ten macroeconomic balance indicators for the EU’s economies for the year of 2010 presented in the AMR makes it possible to identify countries with similar achieved values. A question suggests itself whether the presented decision of the Commission really takes into consideration the mentioned wider context of the development of the EU economies, i.e. the continuous development of indicators, the predicted development and possible spillover effects, or whether it is simply based on empirical data.

A multidimensional statistic method has been chosen for the initial analysis – namely cluster analysis that sorts out sets of objects into several relatively homogeneous clusters [6]. Unfortunately this method cannot provide an answer to the

hypothesis defined above; however it can classify the EU economies according to defined comparable macroeconomic data.

Via the statistic program STATISTICA hierarchical clustering and the Ward's methodology were used to determine groups on the basis of achieved values for all the indicators of the macroeconomic balance indicator set of the EU economies. The Ward's method was identified as suitable for this task because its principle is not optimisation of distances between clusters but the method lies in minimization of the heterogeneity of clusters according to the criterion of the minimal increase in the within-cluster sum total of the squares of deviations of objects from the focus of clusters [8]. The Euclidean distance was used to calculate the distances.

Image 1 interprets in an illustrative manner the results achieved within cluster analysis, i.e. it depicts similarity between EU economies according to the values of the macroeconomic indicators and creates clusters out of them on the basis of this similarity.

The dendrogram shows that the most similar development can undoubtedly be identified with the Czech Republic and Lithuania, further with France and Austria, with Sweden and Denmark, and with Poland and the Slovak Republic, because the distances between these countries achieve the lowest values, i.e. these economies are considerably similar to one another. If we compare the identified results with the conclusion of the EU Commission, we can see that the pairs of economies identified by us belong to the same groups according to potential as well as real dangers of macroeconomic imbalance.

If we continue the clustering process we will see that up to the linking distance of 100 clusters are characterised by a very high level of similarity. The subsequent clustering creates groups of states that are more differentiated. However the distance between 287.9 and 370.2 represented by four clusters in total is very interesting. We chose the distance of 300 for our subsequent detailed analysis. The most similar cluster is formed by Romania, the Slovak Republic, Poland, Lithuania and the Czech Republic. The second cluster is the most numerous one as to the quantity of included states and is composed of eleven countries; namely Slovenia, Finland, Austria, France, Italy, Germany, Greece, Hungary, Latvia, Estonia and Bulgaria. The third created cluster is composed of economies that are encountering very serious economic problems, namely these are Portugal, Spain, Cyprus and Ireland. The remaining countries, i.e. the United Kingdom, the Netherlands, Malta, Sweden, Denmark, Luxemburg and Denmark, represent the last cluster. The stated facts are also manifested by the dendrogram, presented below, of hierarchical clustering of the EU members' economies on the basis of their values for the ten key macroeconomic balance indicators.

**Fig. 1: The dendrogram of hierarchical clustering**

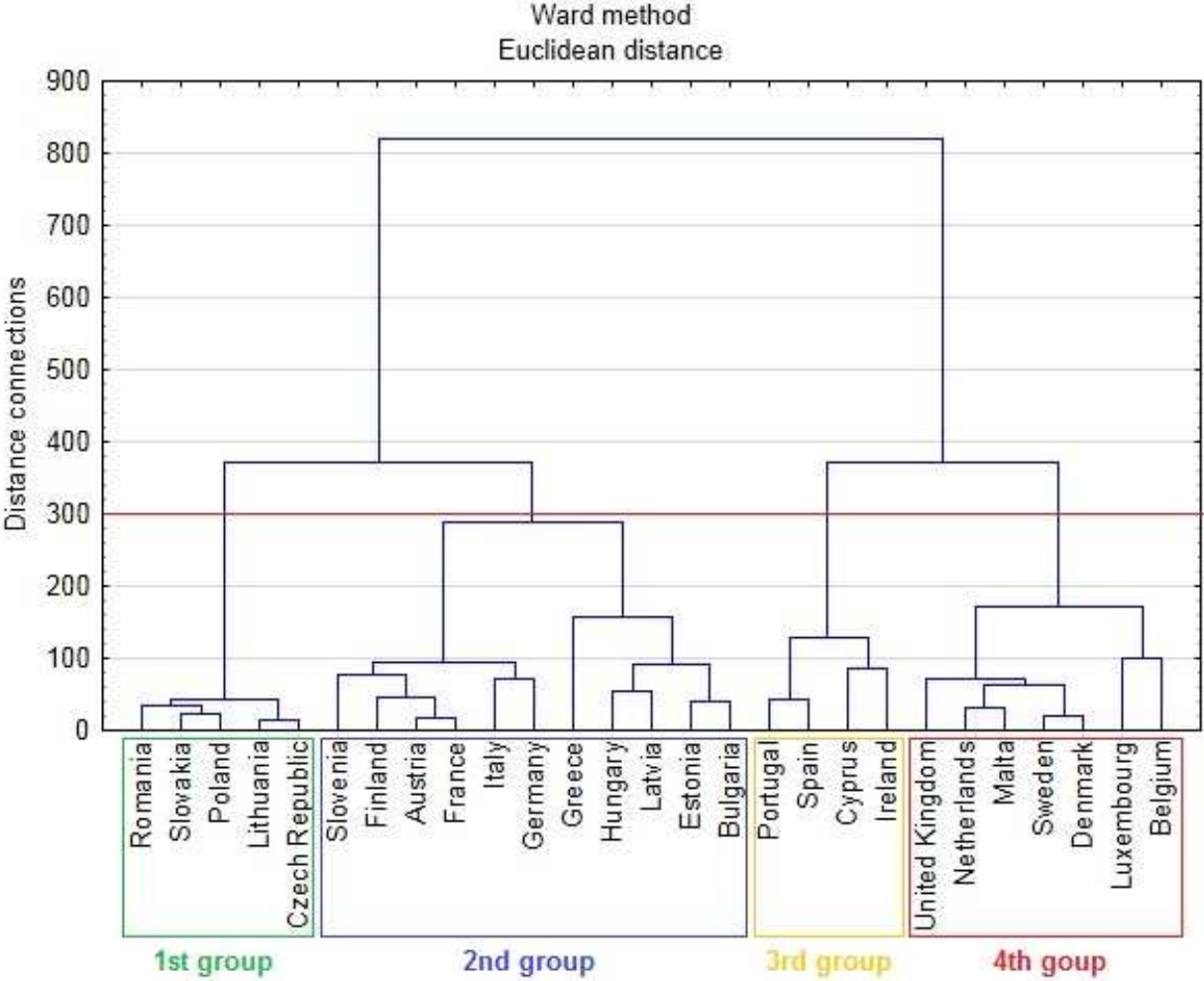

Source: the author according to data from [7].

Before we proceed to compare the clusters created by us with the AMR conclusions it is necessary to take out those economies from the determined clusters that are already under extended surveillance from the EU, i.e. Ireland, Portugal, Greece and Romania. Thus if Romania is not considered in the first cluster, all the remaining countries in the cluster belong among those that are not to undergo detailed analysis according to the Commission’s decision. Similar conclusions may also be drawn on the basis of the composition of the third cluster, which is only composed of economies that are to undergo detailed analysis, if we apply the aforementioned assumption, namely Spain and Cyprus. Unfortunately we do not arrive at such unambiguous results with the remaining two clusters, even if we eliminate Greece, which is already under extended surveillance from the EU. This is to say that the second and the fourth cluster are mainly formed by economies that require detailed analysis in the EU’s view, however they also include countries for which such surveillance is not planned for the nearest period to come.

The chosen multidimensional statistic method, cluster analysis, has sorted out the EU countries into clusters on the basis of the similarity of identified empirical data. Since this method did not focus on the fulfilment of the informative threshold values, not all our conclusions are identical with the those of the EU Commission.

## Conclusion

The issue of macroeconomic balance, or in other words the issue of internal and external imbalances and competitiveness, of economies not only in the EU has been a frequently discussed topic in recent years and that especially in relation to the membership of countries in the EU, however also in relation to the future existence of the EMU as such.

The seriousness of the macroeconomic situation in the EU is manifested, among other things, by the so-called Excessive Imbalance Procedure, which became effective in December 2011. Based on this procedure the EU Commission has created, after consultations with the European Parliament, the European Council and the European Systemic Risk Board, the historically first Alert Mechanism Report, which defines a set of ten indicators of internal and external imbalances and competitiveness and, on the basis of empirical data from all the EU member countries for 2010, decided on the detailed analysis of twelve economies with the objective to look into their various macroeconomic problems in detail.

In the end of this paper macroeconomic balance indicators were analysed on the basis of the cluster method with the objective to confirm or refute the conclusions of the EU Commission. The conclusions can be summed up as follows: the most similar economies undoubtedly are the Czech Republic and Lithuania, France and Austria, Sweden and Denmark, Poland and the Slovak Republic. Our conclusions agree with the Alert Mechanism Report since the mentioned pairs have found themselves in the same groups according to the necessity for further analyses. After creating clusters, applying the distance of 300, and while neglecting those economies that are already under the EU surveillance, we can see that two clusters are typical by their homogeneity. The remaining clusters are mostly formed by economies that require detailed analysis according to the EU; however they also include countries that are not under surveillance at the moment.

Although the mentioned statistical method has led to the presented conclusions, we have to bear in mind that the created clusters were only composed on the basis of the empirical values of the ten macroeconomic indicators; however no weight was given to their fulfilment, i.e. the informative threshold values. This is the reason why not all conclusions presented by us are identical with the Alert Mechanism Report.

Based on the very results received from the executed statistic analysis the next goal of our work has been determined, which lies in the selection of a more suitable statistic method that would take into consideration the wider context and the determined informative threshold values and that would help to verify the opinion of the EU Commission that the set of macroeconomic balance/imbalance indicators has not been determined on a too rigid basis.

## References

- [1] First Alert Mechanism Report on macroeconomic imbalances in Member States. *EUROPA PRESS RELEASES* [online]. [quotation 2012-03-01]. Available at: <http://europa.eu/rapid/pressReleasesAction.do?reference=MEMO/12/104>.

- [2] EU Economic governance „Six-Pack“ enters into force. *EUROPEAN COMMISSION* [online]. [quotation 2012-03-01]. Available at: <http://europa.eu/rapid/pressReleasesAction.do?reference=MEMO/11/898&format=HTML&aged=0&language=EN&guiLanguage=en>.
- [3] Report from the Commission. Alert Mechanism Report. *EUROPEAN COMMISSION* [online]. [quotation 2012-03-01]. Available at: [http://ec.europa.eu/economy\\_finance/economic\\_governance/documents/alert\\_mechanism\\_report\\_2012\\_en.pdf](http://ec.europa.eu/economy_finance/economic_governance/documents/alert_mechanism_report_2012_en.pdf).
- [4] Stability and Growth Pact. *EUROPEAN COMMISSION* [online]. [quotation 2012-03-02]. Available at: [http://ec.europa.eu/economy\\_finance/economic\\_governance/sgp/index\\_en.htm](http://ec.europa.eu/economy_finance/economic_governance/sgp/index_en.htm).
- [5] The MIP framework. *EUROPEAN COMMISSION* [online]. [quotation 2012-03-01]. Available at: [http://ec.europa.eu/economy\\_finance/economic\\_governance/macroeconomic\\_imbalance\\_procedure/mip\\_framework/index\\_en.htm](http://ec.europa.eu/economy_finance/economic_governance/macroeconomic_imbalance_procedure/mip_framework/index_en.htm).
- [6] HEBÁK, P. et al. *Vícerozměrné statistické metody*. 1<sup>st</sup> Edition. Prague: Informatorium, 2005, 255 pp. ISBN 80-733-3039-3.
- [7] KADERÁBKOVÁ, A. *Základy makroekonomické analýzy: růst, konkurenceschopnost, rovnováha*. Prague: Linde, 2003, 175 pp. ISBN 80-861-3136-X.
- [8] MELOUN, M. Přednosti analýzy shluků ve vícerozměrné statistické analýze. In: *Zajištění kvality analytických výsledků: sborník přednášek ze semináře 22.-24.3.2004 [na Medlově]* [online]. Český Těšín: 2 Theta, 2004 [quotation 2012-01-21]. ISBN 80-86380-22-X. Available at: <http://meloun.upce.cz/docs/publication/152.pdf>
- [9] Informative study no. 1/2011. *MINISTRY OF FINANCE* [online]. [quotation 2012-02-21]. Available at: [http://www.mfcr.cz/cps/rde/xbcr/mfcr/Studie\\_reforma\\_spravy\\_ekonomickych\\_zalezitosti\\_EU-112011.pdf](http://www.mfcr.cz/cps/rde/xbcr/mfcr/Studie_reforma_spravy_ekonomickych_zalezitosti_EU-112011.pdf).

## Contact Address

### Ing. Petra Applová

University of Pardubice, Faculty of Economics and Administrations, Institute of Economic Sciences

Studentská 84, 532 10 Pardubice, Czech Republic

Email: [petra.applova@upce.cz](mailto:petra.applova@upce.cz)

Phone number: +420 466 036 668

Received: 28. 04. 2012

Reviewed: 29. 06. 2012

Approved for publication: 01. 11. 2012

# EVALUATION OF TRANSIT LINES PLAN

**Juraj Cenek**

**Abstract:** *The plan of mass transport or transit lines is a vital part of an organisation of public transportation services. An optimisation of the plan can improve the service either by reducing the operational costs or by improving of service quality. Three subjects interact in the problem namely state or local administration, transport companies and citizens. The plan optimisation should find the best compromise to satisfy interests of all actors. A relevant criterion must be defined to find the best solution. Calculating passenger criterion values must include model of passenger's decision.*

**Keywords:** *Transportation planning, Transit lines, Costs criteria, Service quality, Optimization.*

**JEL Classification:** *R41, C61.*

## **Introduction**

Mass transportation or transit services carry passengers to a desired destination. An offer of transit services helps to reduce individual use of private cars and thus improve traffic in towns and their environments. The services must be offered for a reasonable price frequently under real operational costs of service providers and thus they must be subsidised to be attractive for passengers.

### **1 Statement of a problem**

Transit lines optimisation helps to achieve the mentioned goals, namely an offer of quality services at acceptable costs. Basic criteria for evaluating quality of public transportation services are defined in European standard EN 13816 or Slovak standard STN EN 13816. Basic 7 criteria-principles mentioned in the standards are: Accessibility, Information, Time, Customer care, Comfort, Security, Environmental impact. Most of them can not be directly respected in the line plan optimisation as they can be hardly quantified to fit into an optimization model. So only time factors seem to be suitable for use in an optimization process as discussed in the following text.

An optimisation of transit services should find the best equilibrium among the interests of all participating parties, namely:

- Governmental or local administration which subsidises transit services,
- service providers who run the services and try to gain some profits,
- passengers who desire to have affordable and quality services.

The administration bodies try to minimise their involvement and to pay as little as possible to subsidise the transit system. The optimisation model of transit services can

suppose that a fixed contribution is agreed on and available from administration bodies.

Under such an assumption only two parties remain and an optimal solution should respect relevant interests of passengers and service providers. Passengers demand quality service, which can be measured by a total travel time and a service comfort. The travel time (which includes waiting for a vehicle, ride in a vehicle and changing vehicles) should be preferably short and comfort of the offered services should be as good as possible (comfort of the ride in a vehicle, walking to the next bus stop or railway station, changing vehicles or transportation modes etc.)

The better a service quality is the higher costs will arise to providers ensuring the services. So there is a contradiction between interests of passengers and service providers. The passengers are interested especially in:

- Travel costs which is pre-eminently given by pricing policy and by real operation costs of providers;
- travel time;
- comfort.

Service providers try to gain some profits which they can achieve by reducing their operational and fixed costs or in other words by minimisation of a total distance driven by vehicles and their crews (what reduces fixed costs as well - less distance driven equals less busses or trains needed at a time, less staff, etc...).

The discussed interests of service providers and passengers can be formulated in a simple model shown in the next paragraph. A relevant criterion for an optimisation of a transit system is then a total distance covered by vehicle rides or a travelled distance and time spent by passengers.

In principle, we have to determine the overall market size, based on characteristics of the population and the service. We then assume a launch date and model the diffusion of the service to determine the shape of logistic curve by which saturation level is reached. The diffusion model begins by identifying the total potential market for a service - those users that could potentially be interested in the service, if conditions (prices, network size, etc.) were suitable. From there, we implement a two-stage model showing how members of the potential market becoming aware of the new product, and then how those who are aware decide whether or not to subscribe. The decision to become a subscriber is a result of comparing the benefits and costs of the service.

## 2 Methods

The optimisation of transit lines is an NP hard optimisation problem. There are many known approaches and optimisation models such as models presented in [2], [4], [5], [6]. Many of them are based on a network design model defined as follows.

Transportation infrastructure is represented as a graph  $G$  consisting of a set of nodes  $V$ , a set of edges  $H$  and edge costs  $c$

$$G = (V, H, c)$$



Nodes describe stops in a transit system (bus stops, railway stations etc.) and edges stand for a transport service between origin and destination nodes.

Let us name

$(i, j) \in \mathbf{H}$  – an edge from node  $i$  to node  $j$ ,  $\mathbf{H}$  is a set of all feasible edges,

$(r, s) \in \mathbf{Q}$  – passenger flow from node  $r$  to node  $s$  and  $\mathbf{Q}$  is a set of all passenger flows,

$q^{rs}$  – intensity of flow  $(r, s)$  characterised by a number of passengers travelling during a time period,

$f_{ij}$  – fixed costs of creating an edge  $(i, j)$  which means costs of vehicle operations on line  $(i, j)$ ,

$c_{ij}^{rs}$  – passenger costs for travelling along an edge  $(i, j)$ , frequently can be substituted by cost  $c_{ij}$  independent origin and destination of passenger's travel,

$y_{ij}$  – binary decision variable for creating an edge, which means edge  $(i, j)$  is created ( $y_{ij}=1$ ) or is not ( $y_{ij}=0$ ),

$x_{ij}^{rs} \in \{0, 1\}$  for all edges  $(i, j) \in \mathbf{H}$  and flows  $(r, s) \in \mathbf{Q}$  are binary decision variables signifying that the edge  $(i, j)$  (in other words transport service between nodes  $i$  and  $j$ ) is (for  $x_{ij}^{rs} = 1$ ) or is not (for  $x_{ij}^{rs} = 0$ ) used for transportation of a passenger flow  $(r, s)$ ,

The optimisation model for the network design problem can be formulated as follows:

Costs function

$$\min \sum_{(i,j) \in \mathbf{H}} f_{ij} \cdot y_{ij} + \sum_{(r,s) \in \mathbf{Q}} q^{rs} \cdot \sum_{(i,j) \in \mathbf{H}} x_{ij}^{rs} \cdot c_{ij}^{rs} \quad (1)$$

subject to constraints:

$$x_{ij}^{rs} \leq y_{ij} \quad \text{for } (i, j) \in \mathbf{H}, (r, s) \in \mathbf{Q} \quad (2)$$

$$\sum_{(i,k) \in \mathbf{H}} x_{ik}^{rs} - \sum_{(k,j) \in \mathbf{H}} x_{kj}^{rs} = \begin{cases} -1 & \text{for } k = r \\ 1 & \text{for } k = s \\ 0 & \text{for } k \neq r \text{ a } k \neq s \end{cases} \quad \text{for } (r, s) \in \mathbf{Q} \text{ and } k \in \mathbf{V} \quad (3)$$

$$x_{ij}^{rs} \in \{0, 1\} \quad \text{for } (i, j) \in \mathbf{H}, (r, s) \in \mathbf{Q} \quad (4)$$

$$y_{ij} \in \{0, 1\} \quad \text{for } (i, j) \in \mathbf{H} \quad (5)$$

The costs function consists of two parts where the first term stands for operating costs of service providers and the second one for passenger costs. If passenger interests are neglected the first term only is significant and corresponding optimisation model is known as travelling salesman problem. If only passenger costs are respected the optimisation will find shortest paths in a complete set of feasible edges (in the graph  $G$ ) for every passenger. A suitable compromise between interests of providers and passengers must be found in real life.

## 2.1 Provider costs

The function of provider costs can be discussed in detail now. The first term of the costs function (1) stands for operational costs, which must be paid by a service provider. A more detailed expression can define the operational costs as

$$f_{ij} = \text{sum} ( d_{ij} \cdot p_{ij} ) \quad \text{for all } (i, j) \in H$$

$d_{ij}$  – costs of one ride along line  $(i, j)$ ,

$p_{ij}$  – number of line trips  $(i, j)$  .

Variable  $y_{ij}$  can be in fact omitted and replaced only by variable  $p_{ij}$ , which will be set to zero if the line is not chosen and so no vehicle run will serve it in a transit service plan.

Distances or costs  $d_{ij}$  depend mostly on the length of the line and are well known at the moment of a design of a set of feasible lines. The problem arises with number of rides  $p_{ij}$ . The service frequency on a line is determined by several factors as:

- expected (predicted) number of passengers known from an O-D matrix,
- minimum frequency of a service estimated by enforced standards,
- expected (desired) occupancy of vehicles.

A significant criterion is needed to evaluate a quality of a transit lines plan. For a comparison of a new plan quality against the old one currently in use the best way would be to suppose that the number of runs on a line ensures the same quality of service at all bus stops or railway stations as is currently offered. Further optimisation can estimate a proper number of line runs and their departure times so that a better efficiency of the system is attained and operational costs are lowered or service quality is improved.

## 2.2 Passenger costs

Passenger's costs are formulated in the second term of the costs function (1). A more detailed expression can define the passenger's costs as

$$c_{ij} = X \cdot (t_{ij} + tp_i) + Y \cdot l + cp_{ij} \quad \text{for all } (i, j) \in H$$

$t_{ij}$  – in vehicle time  $(i, j)$ ,

$tp_i$  – access time  $(i, j)$ ,

$cp_{ij}$  – price of a ride along line  $(i, j)$ ,

$l$  – quantification of comfort

$X$  – weight of time parameters in the formula

$Y$  – weight of comfort parameter in formula

Passenger costs are rather difficult to evaluate relevantly, because of many factors included. This part of costs function is actually determining, whether a passenger will choose to ride public transportation or not. All of above mentioned parameters are relevant in deciding whether to ride public transportation or not, but there are many parameters that can be hardly included in a costs function formula such as:

- Current weather condition

- outside temperature
- what time of year it is (summer holiday, winter, spring, autumn.... )
- quality of actual ride (comfort of seats, comfort of vehicle and driving)
- distance from home to bus stop or station
- distance from final bus stop or station to destination
- total time of the whole trip
- social and economical status of a passenger
- local customs of passengers etc.

Relevancy of mentioned factors is indisputable, however determining weights of time and comfort parameters along with weights of all other mentioned factors not included in formula would demand a serious analysis by itself. Despite of all the efforts the analysis may bring no valuable results while the final decision on choice of a transportation mode is still taken by a human being. Passenger decisions which depend on actual plan of transit line and other factors should also affect provider costs in costs formula, because it determines number of passengers actually riding a vehicle.

### **3 Problem solving**

Relevant decision criteria and description of passenger's behaviour should result from the discussed costs analysis.

#### **3.1 Relevant criteria**

Evaluating quality of line plan is the same problem as a value estimation of costs function (1), however passenger flows as input data to the above mentioned optimisation model depend on many parameters mentioned in chapter 4. In other words passenger flows depend on a designed plan of transit lines and transit line design is done using data on passenger flows what is a circular dependency which leads to a completely different view on a problem. Costs function value of a solution (designed plan) represents costs assuming that all passengers actually use the public transportation for their whole trip from origin to destination. In reality a lot of potential passengers may switch to another type of transport if the offered services do not comply with their needs. In this point provider income and costs may differ from model results. The correct way to design a line plan would be to design a line plan based on input data from current system, then to implement the designed plan in real traffic, and after stabilisation of passenger flows to collect data on passenger flows and make a new design based on these new data. Designed plan must be evaluated using criteria from both passenger and provider's point of view:

From passenger's point of view:

- Total ride time,
- total distance,
- total count of line transfers.

From provider's point of view:

- Total number of rides,
- total distance driven.

**Total ride time** is a sum of time that passengers spend in a mean of mass transportation or waiting for a mean of mass transportation what reflects a speed of transportation. The only problematic point in evaluation of the criteria is a determination of waiting times for transfers. Number of line trips for every line can be estimated but also departure times of individual trips and intensities of passenger flows during the hours of a day are necessary for a precise calculation of waiting times at transfers. Waiting time can be substituted by a constant value that will not suppress relevance of actual travelling time and also will not become irrelevantly small.

**Total distance** is a sum of all distances that all passengers travelled in means of transport. This value can be calculated by choosing certain decision strategy for transportation route for every passenger and calculating route's distance. This parameter is equivalent with previous one excluding waiting time.

**Total count of transfers** is sum of all transfers of all passengers as getting to their destination using designed plan and certain decision strategy. This parameter describes comfort factor of the designed line plan.

**Total number of rides** is determined by count of runs per day of every designed line. This number can be set only by statistical research, but it cannot be precisely determined while its count is being influenced by many factors where some are not even quantifiable.

**Total distance driven** is a parameter derived from **total number of rides** and there are same problems determining the exact value.

### 3.2 Model of passenger's behaviour

Usual input for evaluating transit line plan includes OD matrix, which consists of numbers of passengers for certain period of time that request to be transported among each pair of nodes in a transportation network. Proposed line plan includes line tracks and their count for one day or for any other defined time period. In this point we can shrink the whole problem of determining evaluation criteria values to a problem of modelling passenger's behaviour.

It is influenced by many factors as:

- Weather (for example we can assume, that during cold or rainy days passenger chooses to wait less on the stop, so the earlier connection is chosen even if it is longer);
- season of the year (similar to weather factor);
- time of day (there are less available connections during night hours, so we can expect strategy „pick first admissible“);
- social and economical status (wealthy passenger chooses higher standard connection, poor (underprivileged) passengers choose cheapest possibility);

- mass transportation comfort level (comfort of vehicle or comfort of certain track can determine passengers decision – vehicle has a restroom, chosen connection’s track is less curvy, etc...);
- speed (chosen connection is faster than other possibility);
- transportation type;
- safety;
- origin and destination stop location;
- track (some track alternatives give nicer views than others);
- day of week;
- waiting time and others.

Combination of all above mentioned factors yields a final decision determining which connection alternative will be chosen to serve a transportation request. Influence factors have an impact on decision whether transportation request will be served by means of mass transportation or not.

Most of above mentioned factors are hardly quantifiable, and can be estimated by statistic methods using observation results of passenger’s behavior in real life situations.

Amount of impact on making a decision by particular factor can be generalized for a group of passengers which have social status, living area, work area, economical status, etc. in common.

Also a set of admissible connections must be determined, what can be done by several methods:

- First  $n$  possibilities (fixed number)
- first  $n\%$  possibilities (percentage of all admissible)
- first  $n$  or  $n\%$  quickest
- connections within time interval (all connections during first  $n$  minutes).

Passenger’s decision fulfills following conditions of a discrete choice, namely

- Alternatives are mutually exclusive,
- alternatives are exhaustive
- the number of alternatives is finite.

A very simple decision model can be formulated as choosing a connection with the maximum probability. Connection  $i$  will be chosen if  $p_i$  satisfies condition

$$p_i = \max_{k \in K} (p_k) \quad (6)$$

where

$K$  – set of available connection alternatives and

$p_k$  - probability of choosing particular connection  $k$  (connections set must include individual transport, too, not only mass transportation alternatives).

Another simple decision rule distributes passengers to connections proportionally to probabilities  $p_i$ . It means from a total number of  $n$  passengers just  $p_i \cdot n$  passengers will use connection  $i$ .

A vital step in the decision process is a correct estimation of probabilities  $p_i$ . Probability of choosing connection  $i$  can be further estimated as

$$p_i = \sum_{j \in F} w_j f_{ij} \quad (7)$$

where

$F$  – set of all impact factors influencing final decision

$f_{ij}$  - probability, that connection  $i$  will be chosen based on impact factor  $j$ .

$w_j$  - weight of impact factor  $j$

Presuming a passenger has to choose one of available alternatives there must hold

$$\sum_{j \in F} \sum_{i \in K} f_{ij} = 1$$

$$f_{ij} \in \langle 0, 1 \rangle$$

$$\sum_{j \in F} w_j \leq 1$$

$$w_j \in (0, 1)$$

Above mentioned model is a type of discrete choice model and values  $f_{ij}$  will be modelled using a suitable logit or probit model (see [1]). Even if the model is known, there is a major problem how to acquire necessary input data, and that is why simplified approaches are chosen frequently.

## Conclusion

As discussed in previous text, decision of potential passengers whether or not to ride public transportation depends on many factors, where some of them are hard to be included into costs function. Passenger's decision making model must be solved to get estimated decision for calculating criterion value from relevant flow intensities on individual transit lines. An optimisation problem stated in (1) – (5) can be solved using a commercial integer programming solvers (e.g. XPRESS). The problem is NP hard and difficult to be solved so a heuristic approach (as described for example in [4]) can be used to get an acceptable solution in a reasonable time. Anyhow, the model is based on a rough and uncertain estimations of passenger's behaviour discussed in paragraph 3.2 and so an approximated heuristic solution seems to deliver appropriate results.

Designing a transit line plan should be periodically repeated and the computed results compared with real passenger's behaviour. The continuous design process will then consist of analysing currently operated mass transport system and taking steps for its improvement. Every change of the system invokes response of passengers what

needs some time to stabilize whole system to a new status to be analyzed. Passenger decisions must be evaluated after every iteration, while total ride time comes out as the only relevant criteria correctly representing quality of the designed route plan.

### **Acknowledgement**

This contribution was supported by the Scientific Grant Agency of the Ministry of Education of the Slovak Republic and the Academy of Sciences under project VEGA 1/0296/12 “Public service systems with fair access to service”

### **References**

- [1] BULÍČEK, J. et al. *Modelování technologických procesů v dopravě*. Univerzita Pardubice, Pardubice, 2012
- [2] CENEK, J., Line routing algorithm, Journal of Information. *In Control and Management Systems*, Volume 8, No.1, 2010, pp.3 -10
- [3] CENEK, J., Evaluation criteria for quality of transit lines plan. *In Journal of Information, Control and Management Systems*, Vol. 9, (2011), No.1
- [4] CENEK, P., KLIMA, V., JANÁČEK, J. *Optimalizace dopravních a spojových procesů*. Žilina : Edičné stredisko VŠDS, 1994. ISBN 80-7100-197-X.
- [5] MAGNANTI, T.L., WONG, R.T. Network and Transportation Planning: Models and algorithms. *In Transportation Science*, 1984, pp. 1-55.
- [6] QUAK, C. B. *Bus line planning, A passenger-oriented approach of the construction of a global line*. 2003 [online]. Delft University of Technology, Delft, Netherlands [Cit. 2008-10-21].  
<<http://www.st.ewi.tudelft.nl/~roos/buslineplanning.pdf> >

### **Contact Address**

#### **Ing. Juraj Cenek**

University of Žilina, Faculty of Management Science and Informatics,  
Univerzitná 1, 010 26, Žilina, Slovak Republic  
Email: [jcenek@gmail.com](mailto:jcenek@gmail.com)  
Phone number: ++ 421 41 72 34 456

Received: 01. 05. 2012

Reviewed: 09. 08. 2012

Approved for publication: 01. 11. 2012

# CLOUD COMPUTING AND INFORMATION SECURITY

Jan Čapek

***Abstract:** The article takes into account cloud computing and information security. It is shown, that in spite of the advantage from costs point of view the data - placed within the cloud are still not safe, due to the fact that providers are not able to secure data from physical point of view. So the customers have not physical control of their data. Existing standard activities cloud for data security does not solve this problem yet.*

***Keywords:** Information security, Cloud computing, Threads, Services, Cloud security.*

***JEL Classification:** D80, D89.*

## Introduction

Information security is a comprehensive approach to information protection as a whole. It is therefore important to protect information in all its forms and throughout their life cycle - i.e. during their formation, processing, storage, transfer and disposal. For effective protection, it is necessary to determine what information the organization has and what value it should. Management of the organizations must identify objectives and real-world performance of their organization and only on the basis that require effective information security management system. It should be noted that the aim is not just implementation, but also other long term development and functionality of the system in a response to changes in the organization and its environment. [3] One of the definitions of cloud computing says “Cloud computing is a method of approach to the use of computer technology, which is based on the provision of shared computing resources and their use as a service”. There are various service models and options for delivery, but all types of cloud computing is the ability to provide shared resources on demand, elastic, self-service and through an extensive network of access and the ability to measure the consumed service in shared resource pool.

## 1 Statement of a problem

Cloud computing is marketing term that refers to web-based application, storage, and communications services. In cloud computing [11], a data centre holds information that end-users would more traditionally have stored on their computers. This raises concerns regarding user privacy protection because users must outsource their data. Additionally, the move to centralized services could affect the privacy and security of users’ interactions. Security threats might happen in resource provisioning and during distributed application execution. Also, new threats are likely to emerge. For instance, hackers can use the virtualized infrastructure as a launching pad for new attacks. Cloud services should preserve data integrity and user privacy. At the same time, they should enhance interoperability across multiple cloud service providers. In this context, we must investigate new data-protection mechanisms to secure data privacy, resource security, and content copyrights.



In a sense, what we're seeing now is the second coming of cloud computing. Almost 50 years ago a similar transformation came with the creation of service bureaus and time-sharing systems that provided access to computing machinery for users who lacked a mainframe in a glass-walled room down the hall. A typical time-sharing service had a hub-and-spoke configuration. Individual users at terminals communicated over telephone lines with a central site where all the computing was done.

When personal computers arrived in the 1980s, part of their appeal was the promise of "liberating" programs and data from the central computing centre. Individuals were free to control their own computing environment, choosing software to suit their needs and customizing systems to their tastes. But PCs in isolation had an obvious weakness: In many cases the sneaker net was the primary means of collaboration and sharing. The client-server model introduced in the 1980s offered a central repository for shared data while personal computers and workstations replaced terminals, allowing individuals to run programs locally.

Management of firms with information security is connected by two bonds. The first link is the marketing. If a company increases its credibility in the market through certification of its quality assurance system should also expect an audit query security information. The second link is a link from the inseparability of information management and the business processes themselves. Business information is known to its own source, like the staff or money. Insecurity threatens the production of own resources and thus leads to an increase risk for the company itself and the rapid spread of threats the surrounding commercial environment. Information security has thus undoubtedly crucial for companies that sell it as part of its production. For example, software, legal, consulting and / or reporting companies even sell it as their main commodity. [2]

## **2 Methods**

In this section, a review of literature, limited mainly to academic articles and recent books are presented. First, searching for articles dealing with cloud computing in general was made. Regarding the fact that objective of this paper is the discussion about data security during cloud techniques using. The final searching area involved security information, where again general literature was used. As the methods the analysis and comparison was used. The article is organised as follows: The first part is dedicated to cloud computing with divide into two subchapters cloud infrastructure and cloud services. The second part is dedicates to Information security within cloud computing.

### **2.1 Related works**

Nowadays a plenty of articles exist in which the cloud computing and/or information security or both are covered. For example [9] the security best practices for cloud computing created by Cloud Security Alliance (CSA). The best practices in designing for the cloud was discussed in [10]. Nice overview article can be found in [11] Cloud Standards is an aggregation site chronicling the progress of several organizations that develop the technological standards for the architecture, control and

security of clouds are discussed in [12]. The Open Web Application Security Project (OWASP) is a not-for-profit organization that develops security software for application testing. OWASP is concerned with Internet and cloud technologies because these areas of study contain myriad application-level vulnerabilities, which are poorly understood by the people who deploy web applications [13].

### 3 Cloud computing

Cloud computing is at the heart of many pragmatic organizations which dislike the increasing complexity and inflexibility of their IT environment and rising operation costs. Cloud computing is attractive for them because it brings the promise of much simpler and more efficient deployment and management of IT. According [14] is possible divide the cloud into two main groups as follow:

**1. The Internal Cloud.** This is, in many ways, the most common type of cloud computing. The internal cloud occurs within a single organization, allowing them to implement virtualization for in-house services. The premise is that internal infrastructure including server, networks, storage and applications will be connected and virtualized, which in turn allows it to move things around in such a way as to maximize efficiency. This is different from a simply virtualized situation in that it allows a higher degree of automation and even a chargeback capability for the other business units.

**2. External Cloud Hosting.** This type of cloud model uses an external service via a cloud provider, and its access by the organization via the Internet. This is probably the most cost-effective way to utilize the cloud. The big concern with this model, of course, is security. Performance is also a concern, in many quarters.

The **External Cloud Hosting** can be divided into four following cloud computing deployment models [15]

**A. Public Cloud.** The traditional mainstream sense of cloud computing. The cloud is made available to the general public or a large industry group and is owned by an organization providing cloud services. Resources are provisioned from an off-site third-party provider who shares resources.

**B. Private Cloud.** The cloud is operated exclusively for an organization. It may be managed by the organization or a third party and may exist on premise or off premise

**C. Hybrid Cloud.** The cloud infrastructure is a composition of two or more clouds that remain unique entities but are bound together by standardized or proprietary technology that enables data and application portability. The environment is consisting of multiple internal and/or external providers.

**D. Community Cloud.** The cloud infrastructure is shared by several organizations. It may be managed by the organizations or a third party and may exist on premise or off premise.

#### 3.1 Cloud Infrastructure

It is an infrastructure necessary to provide (usually transparent) cloud services to users. It includes features for virtualization and federation funds standardize and autom

ate operations processes, user access to computer service and to choose the quality and quantity of services consumed, and finally the method of measuring and billing of services rendered.

One can assume according to [16] that the customer's revenue is directly proportional to the total number of user-hours (UH). This assumption is consistent with the ad-supported revenue model in which the number of ads served is roughly proportional to the total visit time spent by end users on the service.

$$UH_{cloud} \times (revenue - Cost_{cloud}) \geq UH_{datacenter} \times \left( revenue - \frac{Cost_{datacenter}}{Utilization} \right) \quad (1)$$

The left-hand side multiplies the net revenue per user-hour (revenue realized per user-hour minus cost of paying Cloud Computing per user-hour) by the number of user-hours, giving the expected profit from using Cloud Computing. The right-hand side performs the same calculation for a fixed-capacity datacentre by factoring in the average utilization, including nonpeak workloads. Whichever side is greater represents the opportunity for higher profit.

### 3.2 Cloud Services

Cloud services can be divided into:

1. Infrastructure services in the cloud computing environment to ensure compliance with requirements laid down in the agreement on service level (such as performance, availability, and data storage, and security, capacity)
2. Services that provide functionality for cloud computing environments (such as special billing software that ensures that cloud computing environments of different sizes and with different levels of service can be provided by the service charge)
3. Consulting services that help organizations transform and transition to cloud computing
4. Application services provided in cloud computing environments that offer application developers a standardized application functions (eg routines for authentication, search, the implementation of policies or processes according to ITIL)

Rimal et al [5] shows that the cloud can be seen as super services, i.e., providing "everything" as a service. Also shows that the concept of the cloud as a service is not new, but it is an evolutionary development of various previous initiatives, which at the time of its creation, ahead of development. Recall that here, renting computer time has been known since the inception of computers, systems, client - server are also long known, virtualization was already possible in the time of mainframes, etc.

**Fig. 1: Cloud as a service "everything" according to [5]**

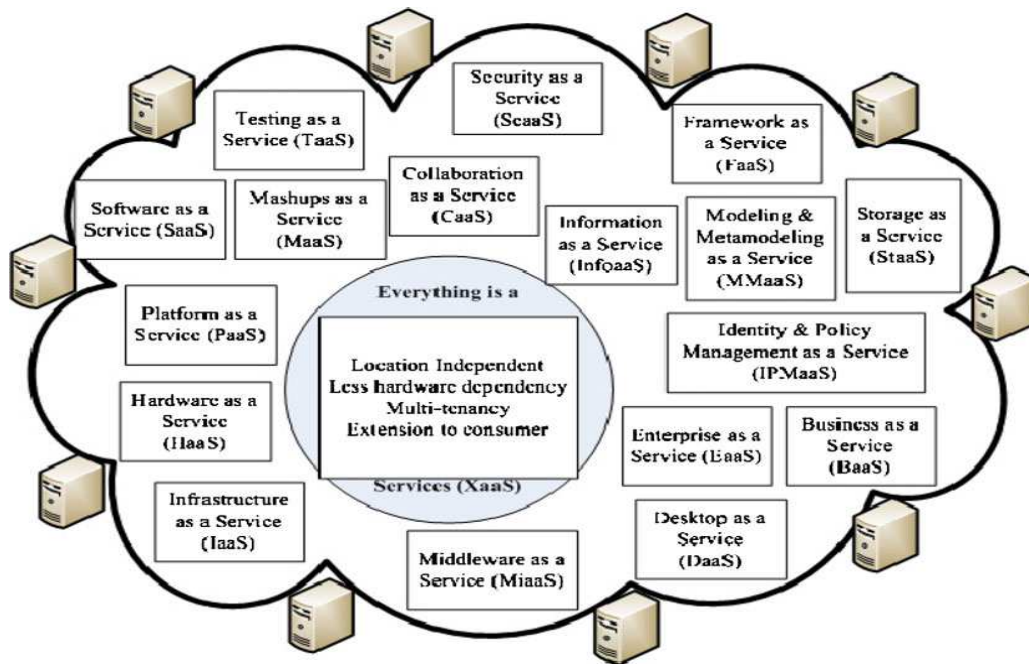

Source: [5]

#### 4 Information security in the Cloud

According to a recent global survey (conducted in May 2011) between 1200 responsible persons from the USA, Great Britain, Germany, India, Canada and Japan (from companies with more than 500 of employees) conducted by Trend Micro [7], was revealed uncertainty and concerns about their journey to the cloud. In this global survey almost half (43%) of those persons responsible for making decisions on corporate IT in the past 12 months, on the side of the cloud vendors, recorded errors or problems in securing the cloud.

**Fig. 2: Safety evaluation of the cloud according to [7].**

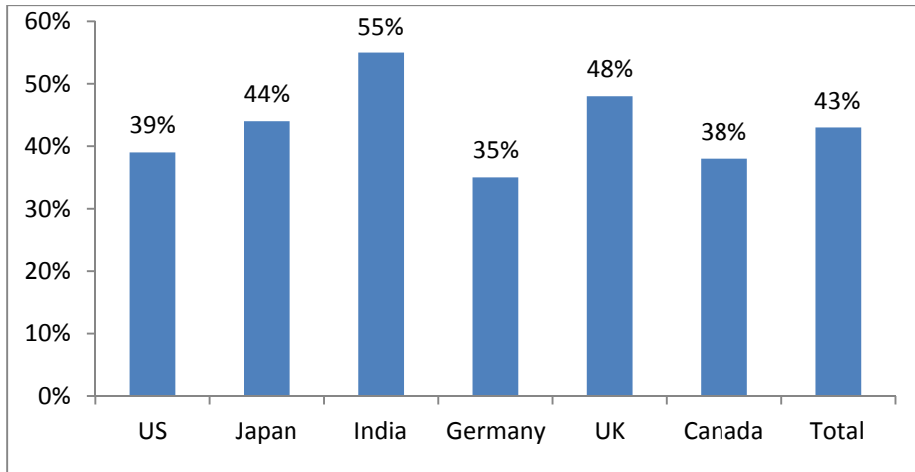

Source: [7]

Another interesting question from Trend Micro [7], Questionnaire Q: How much do you agree or disagree with the following statements about cloud vendors / cloud computing services?

**Fig. 3: Statements of the cloud vendors / cloud computing services according to [7]**

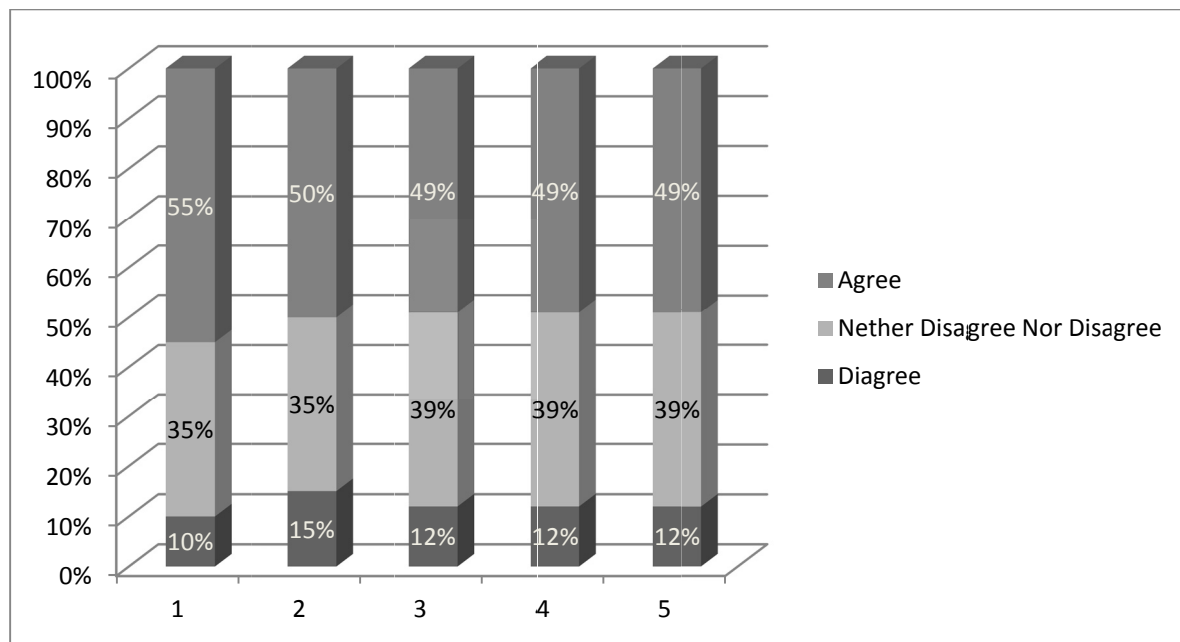

Source: [7]

Where denoting of X- axes meaning:

- 1 – Shared storage is vulnerable without encryption.
- 2 - Apprehension over security is a key reason holding back our adaption of cloud technologies.
- 3 – A guaranteed SLA would drive us to use more cloud computing services/cloud vendors.
- 4 – If knew more about how to secure our data in the cloud, this would increase our consideration of using the cloud.

## 5 – An easy to administer cloud encryption service would give us reason to consider using more cloud services/cloud vendors.

Conclusions of previous investigations are not surprising. In the cloud are no longer traditional boundaries between what is inside the company, and what is outside. Many services now operating within the institution is moved (outsourced) to other operators and a growing part of business processes to take place on the Internet. And it is well known that from the perspective of security much more complicated than the internal corporate network.

Although the storage information stored encrypted, so you must be decrypted before processing, because in an encrypted form cannot be further processed, it can be a source of leakage. Another reason for this is that the service provider cannot beneficiaries of services to provide physical control over the data that you stored in the storage cloud.

### Conclusion

The article discussed the currently very topical issue of information security related to cloud computing, which is in service at the forefront of professional interest of the community. In terms of information security not yet all has been resolved. Even when there has been a non-profit organization established. Cloud Security Alliance (CSA) [8], which seeks to introduce cloud computing universally binding standards which providers would have to follow, the results are still small. CSA is made up of manufacturers of security solutions, independent experts and providers of cloud services.

### Acknowledgement

This article was supported by grant provided by the Ministry of Interior No. VF20112015018 “Bezpečnost občanů – Krizový management”

### References

- [1] Cloud [cit. 2011-09-15]. Available at WWW: <<http://www.cloud.cz/cloud-computing/158-cloud-computingco-ty-pojmy-znamenaji.html>>
- [2] KOSTIHA, F. *Bezpečnost informací. Ikaros* [online]. 2006, roč. 10, č. 5 [cit. 2011-09-28]. Available at WWW: <<http://www.ikaros.cz/node/3332>>. URN-NBN:cz-ik3332. ISSN 1212-5075
- [3] POŽÁR, J. *Vybrané hrozby informační bezpečnosti organizace*, [cit. 2011-09-28]. Available at WWW: <<http://www.cybersecurity.cz/data/Pozar2.pdf>>
- [4] PŘIBYL, T. *Outsourcing bezpečnosti: nemilovaný, leč nutný* [cit. 2011-09-28]. Available at WWW: <<http://www.ictsecurity.cz/odborne-lanky/outsourcing-bezpenosti-nemilovany-le-nutny.html>>
- [5] RIMAL, B., JUKAN, A., KASTROS, D., GOELEN, Y. *Architectural Requirements for Cloud Computing Systems: An Enterprise Cloud Approach. Journal of Grid Computing* Volume 9 No 1/ 2011 pp 3-26 ISSN1570-7873 (Print) 1572-9184 (Online)

- [6] ŠVEC, P. *Cloud computing v praxi: cloud a bezpečnost* [cit. 2011-09 15]. Available at WWW <<http://www.itbiz.cz/cloud-computing-v-praxi-cloud-a-bezpecnost-1>>
- [7] <http://www.cleverandsmart.cz/cloud-computing-bezpecnost-v-cloudu-a-rizika/>
- [8] Cloud Security Alliance (CSA) – security best practices for cloud computing. (2009). Retrieved April 16, 2012, from <<http://www.cloudsecurityalliance.org/>>
- [9] BERRE, A. J., ROMAN, D., LANDRE et al. (2009). *Towards best practices in designing for the cloud. In Proceeding of the 24th ACM SIGPLAN conference companion on Object oriented programming systems languages and applications* (pp. 697-698). Orlando, Florida, USA: ACM. Retrieved from <<http://portal.acm.org.library.capella.edu/citation.cfm?id=1639950.1639970&coll=portal&dl=ACM&CFID=80867670&CFTOKEN=24312614>>
- [10] HAYES, B. *Cloud computing. Commun. ACM*, 51(7), 9-11. Retrieved from <[http://portal.acm.org.library.capella.edu/ft\\_gateway.cfm?id=1364786&type=html&coll=portal&dl=ACM&CFID=80867670&CFTOKEN=24312614](http://portal.acm.org.library.capella.edu/ft_gateway.cfm?id=1364786&type=html&coll=portal&dl=ACM&CFID=80867670&CFTOKEN=24312614)>
- [11] CloudStandards. (2010). Retrieved April 16, 2012, from <<http://cloud-standards.org/wiki/>>
- [12] OWASP. (2010). Retrieved April 16, 2012, from <<http://www.owasp.org/index.php/>>
- [13] JÄÄTMAA, J. *Financial Aspects of Cloud Computing Business Models*. 2010 Retrieved April 16, 2012, from <<http://www.intertic.org/Policy%20Papers/Jaatmaa.pdf>>
- [14] ARNHEIM, D. *Top Four Cloud Computing Models*. Available at [www: http://cloudcomputing.sys-con.com/node/1546627](http://cloudcomputing.sys-con.com/node/1546627)>
- [15] ARMBRUST, M., FOX, A., et al (2009) *Above the Clouds: A Berkeley View of Cloud Computing*, Retrieved, April 16, 2012 from <<http://radlab.cs.berkeley.edu/>>

## Contact Address

**prof. Ing. Jan Čapek, CSc.**

University of Pardubice, Faculty of Economics and Administration, Institute of System Engineering and Informatics

Studentská 94, 532 10 Pardubice, Czech Republic

e-mail: [capek@upce.cz](mailto:capek@upce.cz)

Phone: +420466036511

Received: 01. 05. 2012

Reviewed: 30. 06. 2012

Approved for publication: 01. 11. 2012

# THE RELATION BETWEEN AIR TRANSPORT AND SELECTED ASPECTS OF THE REGIONAL ECONOMY

Michal Červinka, Tomáš Tykva

**Abstract:** *In articles already published in 2010 – 11, the authors clearly defined and specified the relationship between the existence of the airport in a particular region and the regional economy. This delineation was based primarily on studies conducted by professional groups of companies operating in the aviation industry and the leading associations.*

*This article aims to expand on previous research and presents the results of empirical research, which confirms originally formulated relations.*

*With the aim of verifying the formulated hypotheses, diagnostic missions have been applied to the international airports in Brno, Bratislava and Karlovy Vary in order to obtain primary data. Subsequently, interviews with operational experts from the airport have been carried out. Furthermore, current evidence has been collected regarding the number of passengers who have checked in observed periods. The authors have also performed an analysis of the horizontal development of staff (internal and external<sup>3</sup>) and it is in relation to the number of checked in passengers at airports surveyed.*

**Keywords:** *Air transport, Regional airport, Regional development, Regional economy, Socio-economic impact.*

**JEL Classification:** *R11, L93.*

## Introduction

The air transport is an authentic reflection of the performance of the national economy, where changes in growth or decline in GDP are relatively quickly reflected in the performance of the air transport particularly in as far as changes of the number of passengers are concerned. The air transport is very sensitive to the various global crises and disasters (tsunamis, terrorist attacks, disease) and also to movements in oil prices on world markets [6], [10].

The region, which is appropriately connected to other parts of the country and abroad, has much fewer problems with the spatial movement of human resources (the workers can commute from other regions or, conversely, local residents without major difficulties, arising from the transport accessibility, can work in other regions). Good transport accessibility is also a factor which significantly influences the location and investment decisions of entrepreneurs. The region with good transport links is attractive for both, domestic and foreign investors. In the case of the transfer of

---

<sup>3</sup> In this context, an airport employee is referred to as a subcontractor's employee, who is allowed, by means of the ID card, to access operational premises of the airport with the aim of carrying out some of service related activities, which are crucial for securing the operation of the airport.



modern technologies in the context of globalization, internationalization, and others, it can play a positive role in the air transport. The regional governments are aware of this fact in each region, as well as the European Union.

The air transport influences the spatial population movements, and has many side-effects, which are showed in a study presented by York Aviation and the Airports Council International, entitled "The Social and Economic Impact of Airports in Europe". This study also deals with the creation of jobs related to the air transport in the region equipped by airport [12].

The article describes the influence of the existence of the airport on the regional development and economic level. As evidenced by the study above, the airport can contribute significantly to the economic growth in the region. Estimates of the combined effect of direct, indirect and induced impacts vary between 1.4 - 2.5% of GDP (without tourism). This may substantiate the conclusions of other studies, namely the study by the organization ATAG [4] and IATA [9]. It states that the quality of the air service affects the company when deciding where to invest. According to the survey 52% of companies considered international (air) transport links as a fundamental factor in their location decision in Europe.

## **1 Statement of a problem**

### **1.1 Airports - regional economic motors**

Airports are a part of the indispensable infrastructure for a wide range of economic activities. This important economic role is known as the catalytic impact, arising from the effect that air service accessibility can have the positive influence on the region served by the airport. Access to markets and external and international transport links are regarded as absolutely essential to businesses making location decisions. The catalytic effect of an airport operates largely through the enhancing business efficiency and productivity by providing easy access to suppliers and customers, particularly over medium to long distances. Global accessibility is a key factor for the business location and success in all regions of Europe [12, p. 11].

Airports with available lands are developing business parks to capitalise on the attractiveness of the air service connectivity to businesses [8, p. 41]. These business parks are used frequently by firms with some connection to the airport or aerospace industries. Otherwise they are selected as locations for companies making an intensive use of the air transport. Cases in point include Cork, Hamburg, Nice etc.

Although airports are major generators of the economic prosperity through their direct and measurable economic contribution, as it is discussed in section 4, their most important function is the role they play in securing accessibility that allows other businesses to develop. Airports are an essential part of the regional economic infrastructure and it is important that the growth of airports is seen as an integral part of national and regional economic development strategies.

Airports facilitate the economic growth at regional and national levels, on the other hand they also act as magnets for a wide range of economic activities. This wider

economic role of airports is known as the catalytic impact, arising from the effect that air service accessibility can have on the region served by the airport. The mechanisms through which it operates relate largely to enhancing the business efficiency and productivity by providing easy access to suppliers and customers [14, p. 18]. The effects are observed through the role of the airport in:

- Influencing the company location decisions and competitiveness.

The presence of an international airport can be a critical factor in:

- Attracting new inward investments from outside the area, and especially companies from overseas;
- Retaining existing companies in the area, whether they had previously been inward investors or indigenous operations;
- Securing the expansion of existing companies in the face of competition with other areas;
- Promoting the export success of companies located in the area by the provision of passenger and freight links to key markets;
- Enhancing the competitiveness of the economy, and the companies in it, through the provision of fast and efficient passenger and freight services;
- And adding to the quality of the life of citizens by enabling travel, notwithstanding local environmental implications.

## **1.2 The measurable impact of airport activities**

The air transport contributes to sustainable developments. By facilitating tourism and trade, it generates the economic growth, provides jobs, improves living standards and increases revenues from taxes. Increasing cross-border travel is a reflection of the closer relationships developing between countries, both from an individual perspective and at a country level [12]. Air services are particularly important in situations where physical access is problematic.

- **Social benefits**

The air transport contributes to a sustainable generation through purchases of goods and services from companies in its supply chain. The air transport invests substantially in vital infrastructure. Unlike other transport modes, the air transport industry pays for a vast majority of its own infrastructure costs (runways, airport terminals, air traffic control), rather than being financed through taxation and public investment or subsidy (as is typically the case for road and railways).

- **Providing jobs**

In 2030, forecasts suggest that there will be nearly 6 billion passengers and aviation will support nearly 82 million jobs and \$6.9 trillion in the economic activity. However, if the growth were to slow by just 1%, the total number of jobs supported by the air transport sector (including air transport supported tourism) would be over 14 million lower than the base forecasts and the contribution of the air transport sector to the

world GDP would be \$646 billion (2010 prices) lower, with an additional \$542 billion lost through the lower tourism activity [3].

### **1.2.1 Direct impacts**

The aviation industry itself is a major direct generator of employment and economic activities, in airline and airport operations, aircraft maintenance, air traffic management, head offices and activities, which directly serve air passengers, such as check-in, baggage handling, on-site retail and catering facilities. Direct impacts also include the activities of aerospace manufacturers selling aircraft and components to airlines and related businesses.

The air transport also has an important ‘multiplier’ effect, which means that its overall contribution to the global employment and GDP is much larger than its direct impact alone [14, p. 6].

### **1.2.2 Indirect impacts**

These include employment and activities of suppliers to the air transport industry - for instance, aviation fuel suppliers; construction companies that build airport facilities; suppliers of sub-components used in aircraft; manufacturers of goods sold in airport retail outlets; and a wide variety of activities in the business services sector (such as call centres, information technology and accountancy).

### **1.2.3 Induced impacts**

The spending of those directly or indirectly employed in the air transport sector supports jobs in industries such as retail outlets, companies producing consumer goods and a range of service industries (such as banks and restaurants) [6].

### **1.2.4 Other (catalytic) impacts**

One of the other impacts is the fact that the air transport stimulates tourism. Tourism makes a major contribution to the global economy. By 2021, the World Travel & Tourism Council (WTTC) expects the direct employment in the tourism industry to be more than 120 million people globally. Aviation plays a central role in supporting tourism. Over 51% of international tourists now travel by air. Tourism is particularly important in many developing countries, where it is a key part of economic development strategies. This includes jobs in industries such as hotels, restaurants, visitor attractions, local transports and car rentals, but it does not include air transport industry jobs [14, p. 7].

## **1.3 The influence of Air transport on Labour market in Europe**

Below are listed the basic facts about the air transport in Europe [2].

- 605,803,813 passengers;
- 7,860,000 flights;
- 701 commercial airports;
- Air transport supports 8.7 million jobs;

- Generating \$749 billion in GDP in Europe;
- 448 airlines;
- 6,585 aircraft in service;
- 45 air navigation service providers.

**Fig. 1: Summary of the air transport economical influence**

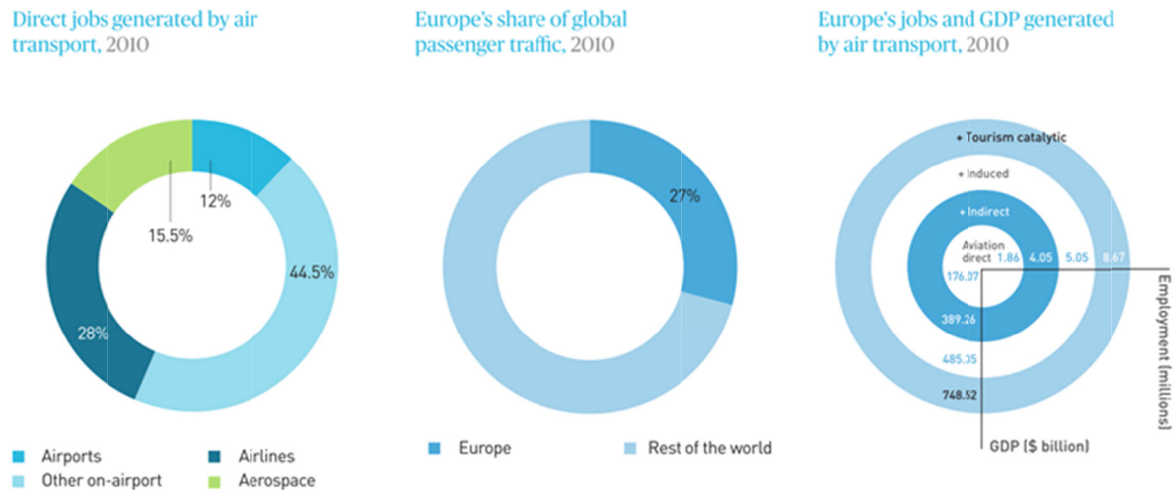

Source: [3]

The number of jobs created directly by the air transport industry is estimated to have reached 1.9 million in 2010.

- 519,000 people (28% of the total) work for airlines or handling agents (e.g. as flight crew, check-in staff, maintenance crew, reservations and head office staff);
- 220,000 people (12%) work directly for airport operators (e.g. in airport management, maintenance, security, operations), while 827,000 (44.5%) work on-site at airports for government agencies such as customs and security, or provides services in retail outlets, restaurants, hotels, etc.;
- 290,000 people (15.5%) are employed in the civil aerospace sector (manufacture of aircraft systems, components, airframes and engines).

In total (direct, indirect and inducted impacts), the air transport supports 5.1 million jobs and contributes with over \$485 billion to GDP in Europe [2].

In addition, there are over 3.6 million jobs supported through the catalytic impacts of travel and tourism.

Nearly two-thirds (64%) of employment comes from airlines, handling agents and aircraft maintenance, with the remainder split between airport operators (14%), in-flight catering, restaurants and bars and retailing (12%), air traffic control and control

agencies (6%), freight (1%) and other activities such as fuel companies and ground transport operators (3%).

In 1998 according to the York Aviation study the European airports created on average 1000 on-site jobs per million handled passengers per year [12]. This number was reduced to approximately 950 on-site jobs per million passengers per annum in 2003. The reason for this lower number was caused by reducing costs and increasing productivity. Other factors i.e. the development of low cost carriers, also supports these trends. [14, p. 23].

The study also estimates that, on average, for every 1,000 on-site jobs supported by European airports there are around 2,100 indirect/induced jobs supported nationally, 1,100 indirect/induced jobs supported regionally, or 500 indirect/induced jobs supported sub-regionally. Given that there are 950 on-site jobs created per million passengers, European airports support around:

- 2,950 jobs nationally;
- 2,000 jobs regionally;
- or 1,425 jobs sub-regionally.

Tourism is the second main element of the catalytic impact. For the EU as a whole, tourism accounts for 5% of the total employment and of GDP, and as much as 30% of the total external trade in services.

## **2 Methods**

For the purpose of creating the article the method of the literature search and expert articles have been applied, further, we have analyzed the expert studies. In order to confirm the hypothesis, diagnostic mission methods (The diagnostic mission included the secondary data collection, airport traffic observation and the interview with airport experts) have been used along with the horizontal and vertical analysis of selected indicators, as well as methods of expert estimations. With the aim of creating the final part of the article, synthetic and deductive procedures have been applied too.

Especially, the method of regression analysis - this method was used to confirm the dependence between the number of passengers and number of jobs generated by the airport. More specifically, regression analysis [11, p. 238] helps to understand how the typical value of the dependent variable changes when any one of the independent variables is varied, while the other independent variables are held fixed. Most commonly, regression analysis estimates the conditional expectation of the dependent variable given the independent variables - that is, the average value of the dependent variable when the independent variables are fixed.

## **3 Problem solving**

The authors of the article have researched the effect of the number of employees at selected airports in relation to the number of passengers handled per year. They also have taken into account the diversity of the structure of traffic at the airports. Bratislava and Brno airports are used by low-cost carriers and charter carriers. There is the presumption of a lower cost for the check-in operation (due to the check-in computerisation and less willingness of passengers to spend money) with fewer staff

required. On the other hand there are almost 100% of customers travelling on regular flights at the Karlovy Vary airport, with a large number of Russian clients who require increased care and travel with more luggage.

**Tab. 1: The result of diagnostic mission**

Airport	Criterion	Year				
		2007	2008	2009	2010	2011
<b>Bratislava</b>	INTERNAL	673	695	630	601	600
	EXTERNAL	2327	2035	2370	1899	2044
	<b>TOTAL</b>	<b>3000</b>	<b>3000</b>	<b>3000</b>	<b>2500</b>	<b>2644</b>
	PASSENGERS	2 024 142	2 218 545	1710018	1665704	1 585 064
	ER	1 482	1 352	1 754	1 501	1 668
<b>Brno</b>	INTERNAL	119	120	126	133	136
	EXTERNAL	240	250	260	262	303
	<b>TOTAL</b>	<b>359</b>	<b>370</b>	<b>386</b>	<b>395</b>	<b>439</b>
	PASSENGERS	415276	506174	440850	396589	557952
	ER	864	731	876	996	787
<b>Karlovy Vary</b>	INTERNAL	38	46	51	56	57
	EXTERNAL	n/a	80	100	108	118
	<b>TOTAL</b>	<b>n/a</b>	<b>126</b>	<b>151</b>	<b>164</b>	<b>175</b>
	PASSENGERS	64641	81720	68369	70903	99014
	ER	n/a	1542	2209	2313	1767

Notes

- INTERNAL..... Employees of the airport company
- EXTERNAL..... Employees of the others subjects i.e. police, suppliers etc. with approved access to the airport
- TOTAL..... Total internal and external employees
- PASSENGERS..... Passengers handled per year
- ER..... Employee ratio = TOTAL/PASSENGERS\*1000000

Source: [authors]

The figures regarding developments at the Bratislava Airport in years confirms partly the conclusions of the mentioned studies [12], [3], [2]. The number of employees is affected by the fact that at the airport, national organisations and entities such as the Civil Aviation Authority and Air Traffic Control operate. An interesting element was the operation of the low-cost airline Sky Europe, which had a base at the airport in 2004-2009. The termination of its activities significantly affected the number of passengers and employees.

Data from the Brno Airport confirmed the conclusions of the studies [12], [3], [2]. It is likely to monitor the increasing of number of passengers with the beginning of the operation of low-cost carriers and the gradual increasing number of the airport staff (internal and external). The number of passengers was about 560 000 in 2011. This

corresponds to about 790 employees. The real number of employees was 436 due to the significant share of passengers of low-cost carriers. This confirms a less labour intensity and higher efficiency of the check-in associated with the computerization of the operation [13].

Data from the Karlovy Vary airport maps the situation of a small regional airport, where the number of employees in relation to handled passengers is higher than at the other airports. This difference is caused due to the fact that despite the lower traffic at the airport, it is necessary to employ workers in the jobs related to the operation in terms of safety (fire and security control) and the staff ensuring air traffic control.

#### **4 Discussion**

Regional aviation, like other modes of transport, is a key enabler in citizens mobility, whereas improved connectivity and efficient inter-modal mobility can contribute considerably to better access to the regions, to business, tourism and the development of related services, and to the spread of economic prosperity [13].

The unequal material status of citizens, and the different levels of infrastructure development, result in disparities in the opportunity to use regional flight connections in the regions. The adequate development of regional airports contributes to parallel development of the tourist system, which is a vitally important area for many European regions.

According to a study of York Aviation in 1998, the average number of jobs created was 1000 per million of checked in passengers [1]. According to the report of York Aviation 2004, the average number of jobs created fell to 950 per million of checked in passengers. The authors have investigated the influence of the smaller regional airports. In 2012, at the airport in Bratislava the number of direct created jobs per million passengers amounted to 1668. If we miscalculated (extrapolated) the number of direct employees per million at Brno Airport, then we can come to 790 of checked in passengers.

Karlovy Vary Airport is not included in the discussion. As a result of its low number of passengers and their specific needs it would not have the sufficient force of expression.

With the increasing number of passengers at the airport, the number of direct jobs created per million passengers is further reducing. For example in the calendar year for 2012 the Luton airport is expecting to handle 10.2 million passengers. Meanwhile, it is estimated that Luton will drive an additional 440 direct on-site jobs for every extra million passengers that pass through the airport, and as a result, an estimated additional 1,750 indirect jobs [11]. This confirms that the relationship between the number of passengers and number of jobs generated by the airport is not linear and is also affected by local conditions and traffic structure. It was (among others) confirmed by regression analysis. It can be inferred that the addition of new jobs created due to an increasing the number of passengers will be less progressive at the airport with significant volume of handled passengers.

With the development of new technologies and business models (especially LCC – Low-cost carriers) the reduction of direct job opportunities for one million checked in

passengers is taking place. However, this decrease is compensated by the increasing the number of passengers, and thus the absolute number of jobs at the airport. Airports therefore remain an important driver for the development of the regional economy.

Some regional airports are operational only during mass tourism seasons, which often poses an added problem of organisation, involves higher unit costs, etc.

Certain practices of low-cost airlines, which often operate from regional airports can cause economic problems for regional airports. The present aggressive business practice of some low-cost airlines operating from regional airports to take advantage of their dominant position, and given that commercial activities are a major source of income for regional airports (for example landing fees). Number of passengers should not be the only indicator for the evaluation of airport.

Regional airports should not be tools for increasing public deficits and should generally be economically sustainable in the mid term [13].

The role of regional airports in acting as a mainspring for the development of innovation clusters by diminishing location costs for start-ups, especially in geographically remote regions.

## **Conclusion**

The European regional airports and air services need to be considered as key elements in creating an efficient and well functioning EU transport network that facilitates trade and ensures mobility for a greater number of people. Regional aviation can play a vital role in ensuring that free movement in the EU is a reality not only for people living in major capital cities but also for EU citizens living outside of these areas, ensuring that these cities and regions enjoy not only the benefits brought about by greater mobility but also by generating tourism, providing access to new markets and by attracting greater inward economic investment.

Worldwide, the European region represents 15% of the total jobs and 34% of the GDP generated by the air transport industry, including the catalytic impacts. Moreover, forecasts indicate that this impact is set to grow rapidly over the next 20 years. Passenger numbers are expected to almost double from 605.8 million in 2010 to nearly 1.2 billion in 2030; such an expansion in activity should generate significant economic returns. Oxford Economists forecast that aviation's direct contribution to GDP will increase by 4.4% per annum in real terms over the next 20 years helping to create an additional 841,000 jobs across the region by 2030. Meanwhile, when accounting for catalytic effects in terms of increased tourism receipts, the real GDP growth is also projected at 4.4% per annum with the implied job creation of 1.6 million. The sector is also a prime target for taxation [3].

The results of research (in Bratislava) confirm partly the conclusions of the mentioned studies [12], [3], [2]. The number of employees is affected by the fact that national organisations and entities such as the Civil Aviation Authority and Air Traffic Control are operating at the airport.



An interesting element was the operation of the low-cost airline Sky Europe, which had a base at the airport in 2004 - 2009. The termination of its activities significantly affected the number of passengers and employees.

These results show a positive impact on the airport, if there is based an airline. They also show the consequences of its leaving the airport. Although the results of air transport worldwide were affected by the economic crisis, which affected the operation of the Bratislava airport, it is possible to monitor air traffic impact on job creation in the segment of airports handling more than 1 million passengers annually. The results of the mission also allow to observe how the number of employees responded to significant decreases of the airport's performance.

The results of Brno Airport basically confirmed the conclusions of these studies. This confirms less labour intensity and higher efficiency of the check-in associated with the computerization of the operation [13].

There is a possibility to monitor the increase in the number of passengers with the beginning of the operation of low-cost carriers and the gradual increasing number of the airport staff (internal and external).

Brno Airport is one of the airports which handled less than one million passengers a year. The results show that the number of employees does not fully reflect the increase quantity of passengers. It is obvious that the airport has to secure its basic functions, such as technical support of the airport (i.e. maintenance, fire safety). Airport needs to ensure these activities, even if minimal traffic and there is no direct dependence on the volume of traffic. Number of employees is influenced by seasonal traffic, where a significant volume of the summer operation of the airport are charter flights.

Selection of the airports allowed to monitor the situation at rather smaller airports and to check the validity of the conclusions of previous studies that have examined primarily large European international airports handled often more than 10 million passengers a year.

Air transport connections are important for developing the local economy and tourism, attracting investors and ensuring the rapid transportation of passengers and goods [5]; recognises the importance of regional airports in improving mobility and interregional connectivity, and in helping to make regions more attractive; notes that tourism is demonstrating its resilience to the economic crisis, and that special attention must be paid to any economic policy aspect or decision likely to support or advance tourism, such as air transport and airport infrastructure projects.

The economic importance of regional airports for regional economic growth and job creation, particularly in less developed or disadvantaged regions; stresses, in that connection, the need to exploit the potential for green jobs more effectively; regrets, however, the high number of insecure jobs in the sector, and maintains that staff working at the airports proper or for companies providing services there or for airlines operating there must enjoy the necessary decent contractual terms and pay rates, and that the working conditions of airport.

## References

- [1] AIRPORTS COUNCIL INTERNATIONAL (ACI). *Creating Employment and Prosperity in Europe. (study)*. Brussels: ACI, 1998. [cit. 2012-4-18]. Available at WWW:  
<[http://www3.cfac.unisg.ch/org/idt/cfac\\_ui.nsf/338a93192a5036c7c12568ff0040fed0/C569909391AADB9EC12572050032EF19/\\$FILE/08+Creating+Employment+and+Proseperity.pdf](http://www3.cfac.unisg.ch/org/idt/cfac_ui.nsf/338a93192a5036c7c12568ff0040fed0/C569909391AADB9EC12572050032EF19/$FILE/08+Creating+Employment+and+Proseperity.pdf)>.
- [2] AIRPORTS COUNCIL INTERNATIONAL (ACI). *European passenger traffic up 4.2% during 2010 (report)*. Brussels: ACI, 2011. [cit. 2012-4-25]. Available at WWW:  
<<http://www.aci-europe.org/component/downloads/downloads/2641.html>>.
- [3] ATAG. *Aviation/Benefits Beyond Borders*. Geneva: ATAG, 2012. [cit. 2012-4-26]. Available at WWW:  
<<http://www.aviationbenefitsbeyondborders.org/sites/default/files/pdfs/aviation-benefits-beyond-borders.pdf>>.
- [4] ATAG. *The economic and social benefits of air transport 2008*. Geneva: ATAG, 2008. ATAG. [cit. 2012-4-22]. Available at WWW:  
<[http://files.aea.be/Downloads/Eco\\_Socia\\_Bene\\_Tran\\_08.pdf](http://files.aea.be/Downloads/Eco_Socia_Bene_Tran_08.pdf)>.
- [5] BRADBOURN, F. *Report on the future of regional airports and air services in the EU*. Brussel: European Parliament, 2012.
- [6] ČERVINKA, M. - TYKVA, T. Marketing Approach Of Air Operator Reflecting The Turbulent Changes In The Global Economy. In *Conditions of the foreign tourism developement in central and eastern Europe*. Wroclaw: University of Wroclaw, 2010. ISBN 978-83-928193-9-4.
- [7] ČERVINKA, M. Vliv online odbavení na zvýšení kvality a efektivnosti odbavení cestujících. In *Increasing Safety and Quality in Civil and Military Air Transport: Mezinárodní vědecká konference, Žilina, duben 2012*. ISBN 978-80-554-519-3. p. 43 - 49.
- [8] DOGANIS, R. *The airport business*. Oxon: Roudledge - Taylor and Francis group, 2005. ISBN 0-415-07877-6.
- [9] IATA. *World Air Transport Statistics*. Montreal: IATA, 2011. [cit. 2012-4-23]. Available at WWW: <<http://www.iata.org>>.
- [10] POLÁCH, J. - VIRGLEROVÁ, Z. Oil prices and dependence on oil reserves. In *Scientific Paper of the University of Pardubice, Series, D, XI* 2011-12-05.
- [11] SEGER, J. – HINDLS, R. – HRONOVÁ, S. *Statistika v hospodářství*. Praha: ETC Publishing, 1998. ISBN 80-86006-56-5.
- [12] *The social and economic impact of airports in Europe*. Study of York Aviation and Airports Council International. 2004. [cit. 2012-4-26]. Available at WWW:  
<<http://temis.documentation.equipement.gouv.fr/documents/Temis/0017/Temis-0017789/12209.pdf>>.

- [13] WELLING, D. Luton airport to expand to 18mppa. In *Aiport World*. Middlesex, 2012. Volume 16, Issue 5. ISSN 1360-4341.
- [14] WILDING, J. *Airport Economic Impact Methods and Models*. Washington, D.C.: ACRvP, 2008.

### **Contact Address**

#### **Ing. Michal Červinka, Ph.D.**

Business School Ostrava, plc.,  
Institute of Professional and Expert Competence in Entrepreneurship  
Michálkovická 1810/181  
710 00 Ostrava – Slezská Ostrava  
Email: [michal.cervinka@vsp.cz](mailto:michal.cervinka@vsp.cz)  
Phone number: +420 595 228 147

#### **Mgr. Ing. Tomáš Tykva, MCI**

Business School Ostrava, plc.,  
Institute of Professional and Expert Competence in Entrepreneurship  
Michálkovická 1810/181  
710 00 Ostrava – Slezská Ostrava  
Email: [tomas.tykva@vsp.cz](mailto:tomas.tykva@vsp.cz)  
Phone number: +420 595 228 143

Received: 01. 05. 2012

Reviewed: 07. 06. 2012

Approved for publication: 01. 11. 2012

# THE APPLICATION OF MASLOW'S HIEARCHY OF NEEDS TO THE ENTREPRENEUR'S MOTIVATION – THE EXAMPLE FROM REGION PARDUBICE

Petr Čížek

**Abstract:** *The article is focused on the Maslow's hierarchy of needs and its application to the entrepreneur's reality. Firstly the terms such as entrepreneur and entrepreneurship are explained and it is examined which character traits differ from the regular managers and employees. Furthermore the Maslow's hierarchy of needs are explained. The main aim of the contribution is to show the different importance of needs for entrepreneurs. The research was made on the entrepreneurs whom operate in the Pardubice region and have 9 employees at maximum. The results show that the self-esteem is more important for the entrepreneurs than the recognition. Therefore one of the main conditions of Maslow's hierarchy of needs doesn't apply. It is also concluded that money related motivation factors are very strong among the entrepreneurs, however majority of the respondents refused to sacrifice their time with family to obtain higher financial income. Interestingly, the satisfaction with the decision to become an entrepreneur is not high.*

**Keywords:** *Maslow's hierarchy of needs, Entrepreneurs, Motivation, Human relations theory.*

**JEL Classification:** *M12.*

## Introduction

The motivation is an age-old issue of theory of management. Pouchová gives the definition of motivation as human behaviour “affected by specific, not always conscious or recognized inner driver forces – incentives, motives”. [9] Therefore for the manager “the relationship between motivation and long term work performance is crucial”. [9]

Teturová & Myšková (2010) state that work motivation currently means an important issue for most of the companies. Every individual has different needs and goals that are trying to be addressed. [11]

The article is focused on the examination of the Maslow's theory of motivation and its application to the entrepreneurs.

## 1 Theoretical Background

### 1.1 Description of the entrepreneur

The word entrepreneurs came from the French language which means “an organizer”. [1] The entrepreneurship can be defined as “an attempt to create value through recognition of business opportunity, the management of risk-taking appropriate to the opportunity, and through the communicative and management skills

to mobilize human, financial and material resources necessary to bring a project to fruition”[5]

According to the theory entrepreneurs tend to have different character traits than managers or employees. The main character traits are:

- 1) Opportunistic trait
- 2) Innovative trait
- 3) Self-confident trait
- 4) Proactive and self-motivated trait
- 5) Visionary with flair
- 6) Willingness to take greater risks and live with even greater uncertainty.

[2]

Burns (2008) explains that entrepreneurs’ “drive and determination comes from being highly self-motivated, amounting almost to an irresistible urge to succeed in their economic goals”. The entrepreneurs tend to have much stronger inner need for an achievement than regular managers. Being entrepreneur means to have “lonely affair, without anyone to motivate and encourage you”. Therefore self-motivation and determination is boundary between success and failure. [2]

One of the solutions for keeping the determination comes from enjoyment. Entrepreneurs are doing what they enjoy, not because they are forced to. Therefore one of the main motivator is self-actualization. [2]

## **1.2 Human relations theory**

Before the human relations theory the managers were convinced that social and psychological environment don’t have any influence on productivity outcomes.

The very beginning of human relations theory lies in Hawthorne Studies which was conducted in 1920s and 1930s at Hawthorne works of the Western Electric Company. [8]. The experiment was based on the examination of the human factor in organizations. The main character of the studies was Elton Mayo. The outcome suggested that the productivity is determined not only by material stimulus but also by psychological and social factors. [8]

Despite of the fact that the researchers from the Hawthorne Studies were mostly criticized, the era of the Human relations theory had begun. The main representatives of the Human relations theory were Alton Mayo, Abraham Maslow, Douglas McGregor, Frederick Herzberg and others.

### ***1.2.1 Maslow’s Hierarchy of Needs Theory***

The psychologist Maslow created the early theory of motivation [10]. He assumed that the main motivation of people is to satisfy various needs which can be sorted in hierarchy of importance [4]. According to Maslow there are five need levels (Figure 1). [7]

**Fig. 1: The Maslow's hierarchy of needs represented by a pyramid**

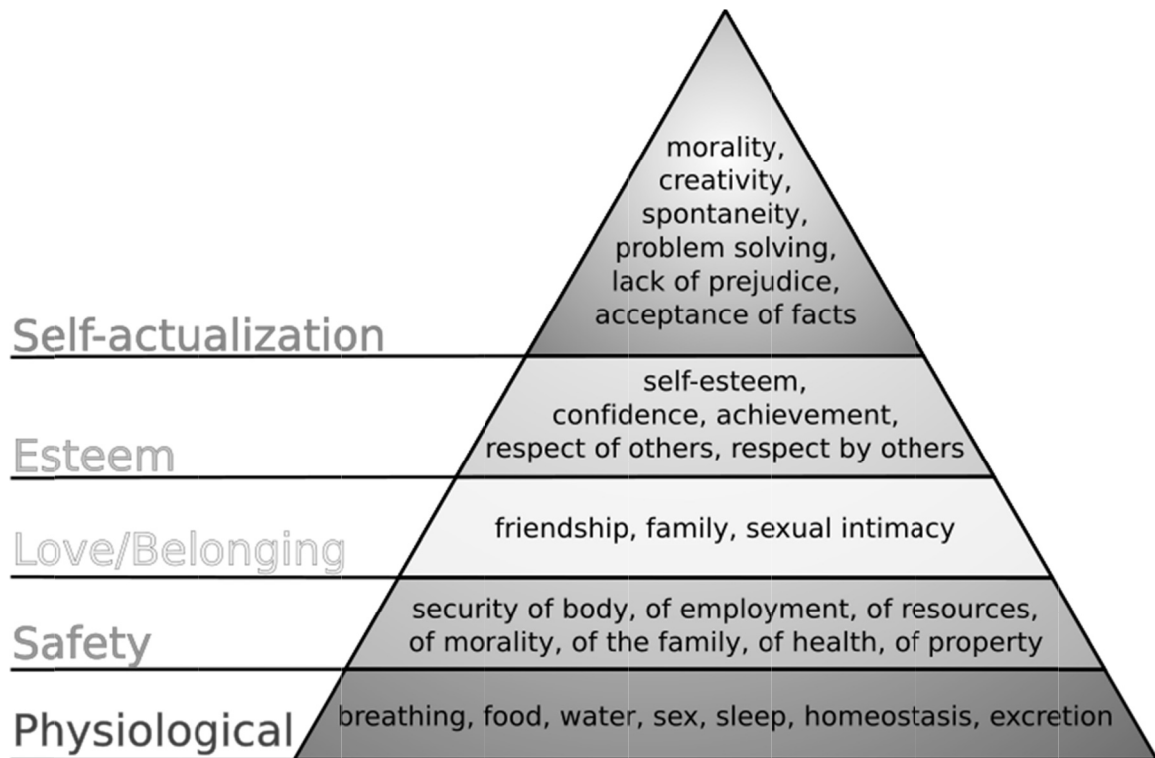

Source: [8]

The physiological needs are represented by needs for things like food, sex, shelter, air and other. The physiological needs represent the essential issues and biological function. [10] According to Griffin in the company, physiological needs are represented by adequate wages and work environment (restrooms, lighting or ventilation) [4]

The safety needs are based on the needs of safety and security – the safety from physical and emotional suffering. In the organizational view, the safety needs are represented by job continuity, grievance system and adequate insurance and retirement packages. Recently according to the situation on the labour market, the safety needs are getting the importance again. [4]

The belongingness needs are related to the social interaction. This includes the needs for love, relationship, friendship, family etc. As the parallel to the organization the team awareness and acceptance are the important part of the management. Also the manager should be sensitive when the employee has family issues. [4]

The esteem needs are the next step in the Maslow's hierarchy of needs. These include the need for self-esteem, confidence, achievement or respect from others. In the organization the esteem needs are represented by job title, spacious offices and rewards. [4]

The self-actualization needs are at the top of the pyramid. They have needs for realizing one's potential and for the personal development. These needs are the most difficult to address by the manager. The examples how to address the self-actualization needs are giving the employee a chance to participate on company's decision making and the opportunity for personal development. [4]

The different levels of Maslow's hierarchy of needs are in this order for the purpose. Individual (employee) is not motivated by the higher needs until he has satisfied the lower needs. Therefore individuals tend to fulfil the needs from the bottom of the hierarchy of needs.

Despite of broad acceptance by managers the Maslow's hierarchy of needs haven't been confirmed by any research. [10]

Koontz (1998) argues that Maslow's hierarchy of needs was examined by many researches. For instance Edward Lawler and J. Lloyd Shuttle gathered the data from 187 managers but the results don't match the hierarchy of needs. The conclusion of this study states that there are only two levels of needs - biological and others. Individuals have to satisfy their biological needs to be motivated by other needs. The other research made by Douglas T. Hall and Khail Nougaim don't prove the hierarchy of needs as well. [6]

The many other theories have emerged as the response to the Maslow's hierarchy of needs (for instance the ERG theory or the Herzberg's Two factor theory). The Herzberg Two factor theory divides the Maslow's hierarchy of needs to the two main factors – motivator and hygienic factors. [6]

## **2 Methods**

The internet questionnaire was used for the purpose of the research. The respondents were defined as entrepreneur running company with 10 employees at maximum. From the total amount of 100 entrepreneurs asked, 24 replied. Thus the respond rate is 24%.

The results of the questionnaire were analyzed by statistical software package Statistica 10.

## **3 Problem solving**

The main focus of the research is on the examination of the top of the Maslow's hierarchy of needs – esteem and self-actualization needs. The aim of the research is to examine these two needs from the view of individual entrepreneurs.

The questions in the questionnaire for respondents were designed for choosing on the scale between 1 to 10 where 1 is the worst possibility and 10 the best.

**Tab. 1: Esteem and self-actualization needs of entrepreneurs**

	Are you satisfied with the decision to become an entrepreneur?	Do you think that you have been recognized in your job?	Do you think that the recognition from the others can motivate you for better performance?	Do you think that you have been self-actualized in your job?	Do you think that you are motivated by the vision of self-actualization?
Arithmetic average	6.31	6.72	7.77	8.13	8.45
Coefficient of variation	42.96	26.82	22.43	23.16	19.9

Source: Author

The results show that the average satisfaction with decision to become an entrepreneur is low. On the other hand the coefficient of variation is 42% therefore the results vary significantly. The recognition in the job is lower than self-actualization. The coefficient of variation is at similar level. The motivation based on vision of recognition is lower than the vision of self-actualization. The averages differ significantly. Moreover in the case of vision of self-actualization the coefficient of variation is relatively low therefore the most of the respondents agree that the self-actualization is important motivator for their job.

The next analysis (Table 2) is focused on the correlation of the satisfaction with the decision to become an entrepreneur and esteem and self-actualization needs.

**Tab. 2: The relationship analysis**

	Do you think that you have been recognized in your job?	Do you think that the recognition from the others can motivate you for better performance?	Do you think that you have been self-actualized in your job?	Do you think that you are motivated by the vision of self-actualization?
Satisfaction with the decision of being entrepreneur	-0.22	0.18	0.25	0.08
Satisfaction with the financial income	0.13	0.13	<b>0.56</b>	0.13

Source: Author



For the correlation analysis it was used the Spearman's rank correlation coefficient on significance of  $\alpha = 0.05$ .

The outcomes from relationship analysis give the ambiguous results. Mostly there haven't been found any correlation. The only significant, but weak correlation was found in the case of satisfaction with the income and the level of self-actualization in the job. Therefore it could be stated that when entrepreneur is satisfied with his income he tends to be also satisfied with his self-actualization.

In the next question, the respondents were asked what motivate them the most to achieve higher performance. This question was designed as open question, but mainly the answers were that entrepreneurs are motivated by money-related factors (43%).

The next part of the questionnaire was focused on the importance of financial income to the respondent. The Figure 2 shows the results where it is possible to see that 41% of respondents are willing to sacrifice the time with family and friends only in case of eminent financial struggling. 32% of respondents are not willing to sacrifice their time with family and friends at all. High portion of respondents are willing to sacrifice their time with friends but not a family (23%) and only 4% of respondents are willing to sacrifice time with family and friends to receive higher income. The results show that most of the respondents are valuing their time with family more than any rise of income. Therefore the motivator of money is not unconditional.

**Fig. 2: The importance of financial income to the respondent**

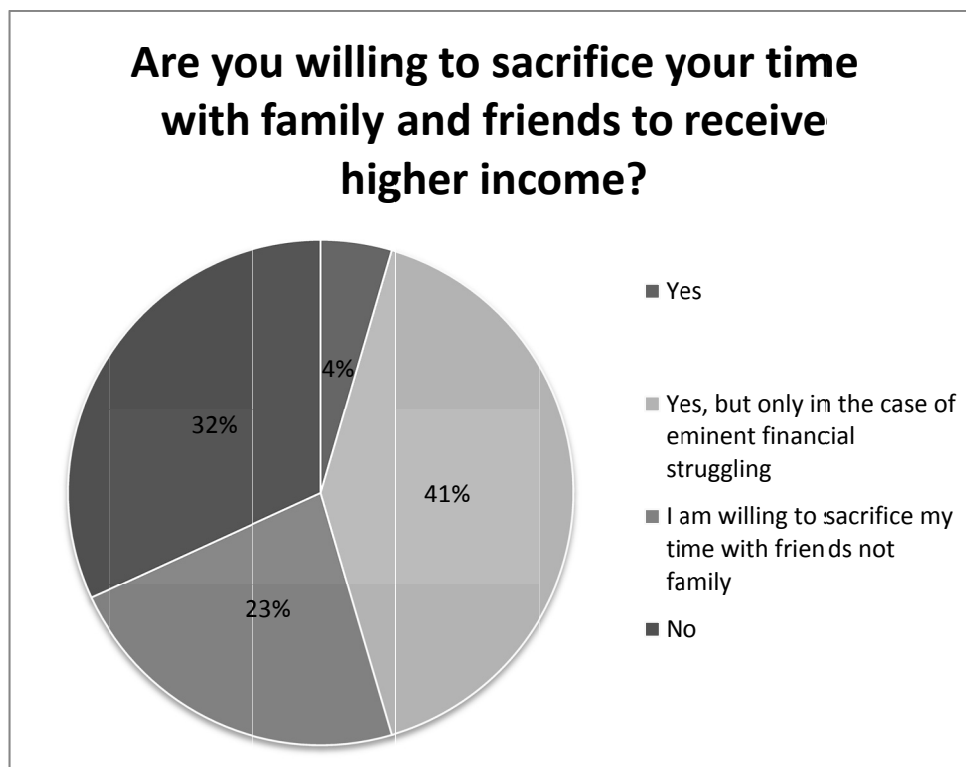

Source: Author

## **4 Discussion**

The Maslow's theory of motivation has strict order of hierarchy of needs. However the entrepreneurs are different from the regular employees. Entrepreneurs have to work with no one to motivate them. Therefore they have to be strongly self-motivated and determined to pursuit their goals.

The research shows that entrepreneurs in Pardubice region are more motivated by a vision of self-actualization even when they don't have satisfied their esteem needs. This is in contradiction with the Maslow's hierarchy of needs. It could be caused by diverse character traits than in case of ordinary employees.

The other interesting result is that entrepreneurs are mostly highly motivated by financial factors however majority of the respondents refused to sacrifice the time with the family to obtain higher financial income.

## **Conclusion**

The human relations theory emerged when Mayo published the outcomes from the Hawthorne Studies. The most spread theory was made by Maslow and it is focused on the hierarchy of needs. The purpose of this article is to show the application of Maslow's hierarchy of needs to entrepreneur reality.

The Maslow's hierarchy of needs divides needs into five levels. The individual can be motivated by higher level of needs just after he satisfies the lower levels. However the research shows that in the case of entrepreneurs this condition does not apply. The entrepreneurs are highly motivated by vision of self-actualization, but in the same time they don't satisfy their esteem needs. One of the possible reasons is that entrepreneurs tend to have different character traits than ordinary employees. Burns (2007) emphasises the different approach to the self-motivation and the importance of self-actualization in the entrepreneurship.

Therefore the results are more close to the study made by Edward Lawler and J. Lloyd Shuttle which argue that the higher needs don't have such strict hierarchy of motivation.

The research also shows that entrepreneurs are highly motivated by financial factors. However majority of the respondents refused to sacrifice the time with the family to obtain higher financial income.

## **Acknowledgement**

This contribution was supported by SG FES 01/2012 fund.

## **References**

- [1] BALU, V. a M. Z. JOHANSON. Entrepreneurship as way of life. Scientific papers of the University of Pardubice. Series D. Faculty of Economics and Administration. 2010, roč. 2010, č. 17. ISSN 1211-555x.

- [2] BURNS, P. *Entrepreneurship and small business*. Basingstoke: Palgrave Macmillan, 2007. 516 s. ISBN 978-0-230-24780-2.
- [3] GREY, Christopher. *A very short, fairly interesting and reasonably cheap book about studying organizations*. 2nd ed. Los Angeles: SAGE Publications, 2009, 187 s. ISBN 978-184-7873-439.
- [4] GRIFFIN, Ricky W. *Management*. 3rd ed. Boston: Houghton Mifflin Co., c1990, 884 p. ISBN 03-954-3333-9.
- [5] KAO, J., STEVENDSON, H. (Eds.), *Entrepreneurship...What it is and How to Teach it*, Division of Research, Harvard Business School, 1984.
- [6] KOONTZ, Harold; WEIHRICH, Heinz. *Management*. 10. Praha: East Publishing, 1998. 999 p. ISBN 80-7219-014-8.
- [7] MASLOW, A. H. *Motivation and Personality*. 3. New York : Harper & Row Publishers, 1970. ISBN 0-06-041987-3.
- [8] NLP & PERSONAL DEVELOPMENT RESOURCES. *Fundamental Human Needs & Phases of Personal Growth* [online]. [cit. 2012-04-20]. Available at: <http://www.askert.com/fundamental-human-needs-phases-personal-growth.html>
- [9] POUCHOVÁ, Lenka. Work motivation and satisfaction in the context of economic crisis. *Scientific papers of the University of Pardubice. Series D. Faculty of Economics and Administration*. 2011, roč. 2011, č. 3. ISSN 1211-555x.
- [10] ROBBINS, S. P.; COULTER, M. *Management*. 11th. New Jersey: Pearson Education Limited, 2011. 643 p. ISBN 978-0-13-216384-2.
- [11] TETUROVÁ, Vendula a Renata MYŠKOVÁ. Komparace motivačních programů vybraných podniků. *Scientific papers of the University of Pardubice. Series D. Faculty of Economics and Administration*. 2010, roč. 2010, č. 18. ISSN 1211-555x.

## Contact Address

**Ing. Petr Čížek, M.A.**

University of Pardubice, Faculty of Economics and Administration

Studentská 84, 532 10 Pardubice

E-mail: [petr.cizek@student.upce.cz](mailto:petr.cizek@student.upce.cz)

Phone number: +420 466 036 665

Received: 01. 05. 2012

Reviewed: 11. 06. 2012

Approved for publication: 01. 11. 2012

# BANK STRESS TESTS, FINANCIAL STABILITY AND SIMULATION OF "FEEDBACK" EFFECT

Monika Garguláková, Jaroslav Belás

***Abstract:** Stress testing is one of the main key quantitative tools for assessment of financial stability. In this process, the assets of banks are exposed to the stress of adverse effects of defined shocks derived from historical and hypothetical scenarios. The aim of stress testing is to verify the hypothetical whether the banking sector is sufficiently resistant to the potential effects of adverse shocks and whether it would not be a threat to financial stability in case of their realization.*

*This article aims to present the current system of stress testing in the Czech Republic and to define the possible impact of selected scenarios for stress testing on the business of banks and capital adequacy. Banks stress testing may result in pro-cyclical behaviour of the banking sector, which under certain conditions may exhibit the reverse negative impact effect on the economy. In the article we use the basic methodology for calculating capital requirements for stress testing, adjusted by own scenarios of adverse shocks.*

*Results of our research point to existing pro-cyclical relationship between regulatory rules and trading activities in the banking sector. Tightening of banking regulation creates conditions for a gradual reduction of the economy performance.*

***Keywords:** Financial stability, Banking regulation, Stress testing, Bank risks, Pro-cyclical behaviour.*

***JEL Classification:** G21.*

## Introduction

Stress tests are used by central banks and regulators as a tool for testing of the institutions resistance or resistance of the whole sector to adverse development of the economic environment. Although stress testing (particularly financial institutions) is performed for many years, the global financial crisis has revealed in many countries deficiencies in up to now established methodology of used test that failed to indicate the start of undermining of the financial stability of the sector and even more outbreaks of subsequent significant shocks. These shocks exceeded the adverse scenarios which were during their compilation in the test periods seen as very unlikely. Because of these facts regulatory rules are strengthened and continuous innovation of stress testing methodologies are done. These rules relate primarily to capital adequacy of banks.

This article aims to analyse the relationship between stress testing and its reverse impact on the management of the bank. This relationship may, under certain circumstances, affect both the financial institution itself and the entire economic system. Certain measures which are based on the test results of individual banks may cause negative repercussions on economic activity and financial stability.

## 1 Financial stability and stress testing

The Central Banks define financial stability as a situation where the financial system fulfils its function without any major problems and undesirable effects. It should also show a high degree of resilience to adverse shocks and unexpected operating events. Therefore, indicators of financial stability are established, whose main objective is to provide a picture of the health of the financial sector as a whole. [9]

Mostly tracked and used basic indicator of financial health at the international level is the capital adequacy ratio, which represents the required amount of capital that banks hold in relation to the risks that it incurs and which often result from actual exposure to financial markets. Capital adequacy is the ratio of equity to risk-weighted assets, off-balance equivalents and market risks. Concept of capital adequacy is intended to serve as a tool through which the banks are forced to hold sufficient amount of capital that will serve to the bank as a buffer to coverage of unexpected losses in times of unfavourable development. [1]

The distortion of stability is the result of both internal and external influences that may cause instability and disruption of the overall economic functioning of both the country and the whole financial system. To test the financial stability of banks is used stress testing which measures banking sector exposure, their sensitivity and resistance to risks. [11]

The bank is the bearer of risk, especially because of the fact that the critical part of its assets consist of financial instruments and financial risk is one of three fundamental aspects of the economic content of each financial instrument. "The financial risk is generally defined as the potential financial loss of a subject that is not already realized or unrealized existing financial loss, but loss resulting from future commodity or financial instrument or commodity or financial portfolio." [15]

The main objective is to limit the emergence and spread of the risk which leads at the end into significant losses throughout the economy in the sense of real output, and may also result into disruption of the proper functions of individual cash flows. Therefore are gradually created stress tests, which are designed to reduce the impact of these shocks.

The first form of the stress tests appears at the turn of 1999 and 2000, when was primarily evaluated the adequacy of policies in the field of financial sector from the view of its stability. Over time, its formation was performed, in which was as an essential element in the test models used comparison and evaluation of the capital adequacy of banks to particular date preceding the shocks (initial capital adequacy) and following the shocks (end capital adequacy). [10]

Methods of the capital requirement calculation are divided into several groups according to the instruments held of the banking portfolio. For purposes of this article and generated simulation of stress testing will be used for capital requirement to credit risk. According to Dvorak is this capital requirement most important of them all. It applies to both balance sheet and off-balance sheet assets included in the banking portfolio. [13]

It is calculated according to the following formula:

$$RWA = (A + B) / 0,08 \quad (1)$$

where RWA are risk-weighted assets of the bank portfolio, for which applies:

RWA = balance sheet RWA + off-balance sheet RWA, where balance sheet RWA represent  $\Sigma$  (risk asset - adjustment) x risk weight, off-balance sheet RWA represent  $\Sigma$  (credit equivalent of off-balance sheet assets) x risk weight, credit equivalent of off-balance sheet assets = (off-balance sheet asset x conversion factor) - reserves. A shows the value for balance sheet RWA and B shows the off-balance sheet RWA.

Risk-weighted assets are included in the calculations of stress testing, which is formulated as follows:

$$CAR = (C / RWA) \times 100(\%) \quad (2)$$

Where C is the capital after taking into account the negative effects of the credit shock, the RWA is risk-weighted assets after taking into account the negative effects of the credit shock and the CAR is final value of the capital adequacy in per cent. [10]

## 2 Predictive models

There is wide range of stress scenarios. Each scenario works with various determinations of individual shocks and the risk that is gradually changing. In connection with effects of the global financial crisis and the instability of the overall financial system was reinforcing the importance of monitoring and predicting tools for better preservation of stability of the system. As the starting points for the correct calculations usage are used alternative macroeconomic scenarios, where is the credit risk used most frequently.

Cipra divides the credit risk into various forms. As **direct credit risk** is inscribed the classic risk of loss from a partner's failure (*default*) for the relevant balance sheet items. It is without doubt the most significant financial risk including the banking system in the CR. **Risk of credit equivalents** is described the possibility of the loss from a partner's failure in off-balance sheet items, which are for example provided guarantees, documentary letters of credit, derivatives, etc. **Risk of credit rating change** – it is risk of loss of opportunities from difficult possibility to obtain at reasonable cost financial sources, which is due to a reduction of official credit rating. As **settlement risk** is inscribed risk of loss from the failure of financial transactions in the process of settlement, where the value was supplied to the partner, but the contract counter value from his side is not yet at the disposal. This risk is typical for the settlement of foreign exchange transactions and the purchase or sale of securities. **Risk of credit exposure** refers to risk of loss from excessive credit exposure targeted on certain partners, states, economic sectors, etc. This risk can be reduced for example by introducing so-called credit lines. [7]

Forecast of macroeconomic and financial variables in the stress tests is directly reflected in the forecast of main balance and flow indicators of the banks. For each item in the assets, liabilities, revenues and expenses there is a default (the last truly known) status to which is added / subtracted the impact of shocks within a given

period (this period is typically one quarter). This final state then serves as a baseline for the next period. This logic is repeated in all periods for which forecasts are generated.

In the following simulation model of various scenarios is working with credit risk, which is used for prediction of the main credit risk parameters, especially the value of the probability of default (PD). This is accompanied by the required capital structure and assigned risk weight.

### **3 Simulation of stress scenarios of feedback effect**

Precise identification of the individual shocks and their range is very difficult. For its needs and better representation this article works with credit risk model, which represents the most significant area of stress tests. This is based on the use of PD values for each of the four major segments of the loan portfolio (non-financial enterprises, loans to households for house purchases, consumer loans to households and other loans). The second parameter of credit risk is the loss given default (LGD), which is expertly adjusted in different levels for different scenarios and different credit segments in accordance with the anticipated development of the economy, including real estate prices, regulatory rules, and practices in commercial banks, approaches applied in some existing credit rating agencies and existing estimates based on market data. The third parameter is the exposure at default (EAD), which is also set up expertly.

The multiplication of these three parameters is the expected loss (EL), which leads to a reduction of capital adequacy:

$$EL = (PD \times LGD \times EAD) \quad (3)$$

To simplify the simulation this article works only with credit risk. For the simulation we have chosen four scenarios in which the capital requirement will be changed in individual years. The basic value of the capital requirement is taken from the Czech National Bank report about financial stability, which at the end of 2010 was 128,041 mil. CZK. The proposed shock scenarios represent for future years increase of this requirement in the following values that involve primarily the increased credit risk.

- 1. scenario - an capital requirement increase of 10%
- 2. scenario - an increase of 15%
- 3. scenario - an increase of 20%
- 4. scenario - an increase of 25%

**Tab. 1: Capital adequacy in individual scenarios**

<b>In millions of CZK</b>	<b>31.12.2010</b>	<b>1.scenario</b>	<b>2.scenario</b>	<b>3.scenario</b>	<b>4.scenario</b>
Total capital requirement	128041	140845	147247	153649	160051
Regulatory capital	240429	240429	240429	240429	240429
Capital adequacy in%	15.02	13.66	13.06	12.52	12.02

*Source: Own processing*

Change in value of the total capital requirement in each scenario is calculated as the sum of the basic values of the capital requirement, which is credited by percentage increase of capital requirement basic value according to the chosen percentage change in the scenario.

The total capital adequacy ratio is then calculated as the quotient of total RWA and regulatory capital, whereas the RWA is calculated as the quotient of the capital requirement and capital adequacy divided by 100, thus by the value of 0.08.

Even though in the different scenarios the capital adequacy did not fell below the 10% barrier, its reduction may cause the rebound of PD parameter. With this change comes an increase in expected loss, which would be reflected in next economy of the bank. The increase in PD risk parameter can have three main impacts on individual banks:

- For each credit segment are calculated expected credit losses, against which banks will form a new provisions in the same amount and account them on the cost side of income statement as impairment losses.
- To reduce the capital adequacy of the bank and therefore increase of its own PD follows another iteration of negative effects transmission on other banks through an increase of expected losses. These iterations take place until this "domino effect" of interbank contagion does not stop, i.e. until the induced increase of one banks or group of banks PD does not lead to an increase of other banks PD. This is the risk of interbank contagion, which represents the mutual exposures between banks.
- The Bank may try to get at the initial value of capital adequacy by additional measures. This causes a rebound of capital requirement, which causes a further reduction of capital adequacy. This leads to cyclical movement, which is shown below.



**Tab. 2: The capital adequacy after repeated increase**

In millions of CZK	31.12.2010	1.scenario	2.scenario	3.scenario	4.scenario
Total capital requirement	128041	140845	147247	153649	160051
Regulatory capital	240429	240429	240429	240429	240429
Capital adequacy in %	15.02	13.66	13.06	12.52	12.02
Total capital requirement after the reduction		153521	166389	179769	192061
Regulatory capital		240429	240429	240429	240429
Capital adequacy in % after the change	15.02	12.53	11.56	10.70	10.01

Source: Own processing

Due to the fact that we are counting in the simulation only with PD, which creates a risk weight of 100% and therefore the only one affects the development, the capital requirement is increased in direct proportion by the percentage that arise as difference between the scenarios. How much was the capital adequacy ratio reduced in %, by the same value again raised the total capital requirement and thus was further reduction in capital adequacy in % realized. This iterative, therefore possibly cyclical development of the capital adequacy reduction is shown on below figure.

**Fig. 1: The development of capital adequacy**

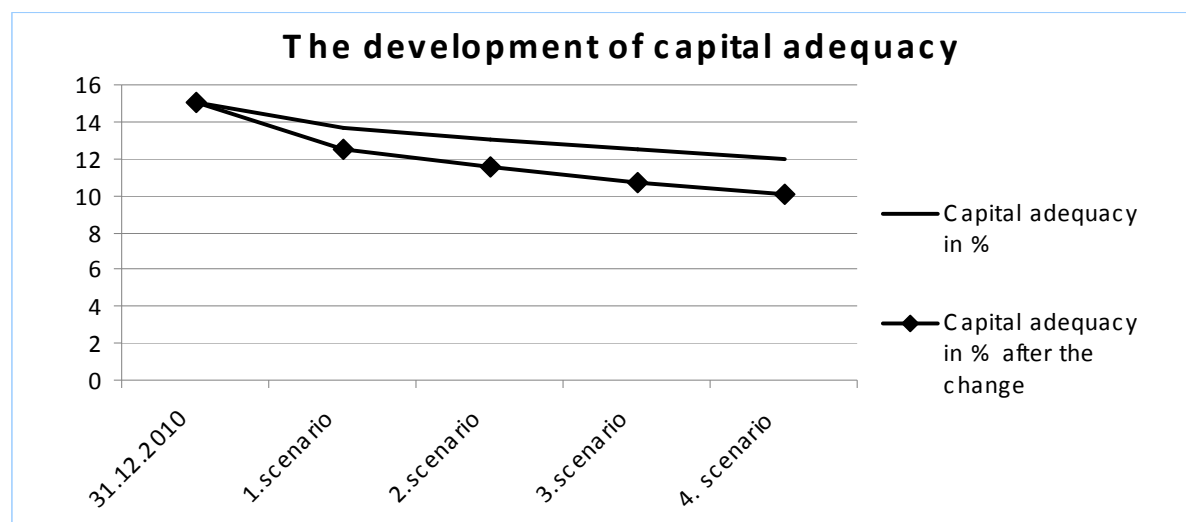

Source: Own processing

For banks which record profit for the whole year is assumed that in the second quarter of the subsequent year are going to decide about profit distribution. In this point is assumed that each bank will be during possible capital increase realized from

retained earnings from preceding financial year trying to get at the initial capital adequacy, if it profit from previous year suffice. According to RWA development can occur several cases:

- Bank distributes whole profit and reinforce regulatory capital (in case of unchanged RWA);
- Bank will use part of the profit to strengthen capital and part distributes (if the RWA increase, but to even up capital for achieving the initial level not whole retained earnings from previous year will be needed);
- Bank will use the whole profit to strengthen capital (in case RWA will increase quite significantly), while according the RWA increase it may happen, that the original capital adequacy will not be achieved;
- Bank distribute in dividends more than its profit amounted to (in the case of a RWA decrease), which divides also part of retained earnings from previous years. [2]

This process may cause re-creation of reserves to maintain the initial level of capital adequacy. This will reduce the inflow of capital into economic activity, which is best represented by the GDP indicator. To better representation we will use generated simulations of the capital requirement with GDP growth.

For GDP indicator predicting we will use the prognosis of the Czech National Bank, which models the evolution of the GDP indicator using internal statistical methods. In the simulated example are data taken and discrete periods replaced with selected scenarios. The prognosis therefore calculates with the following percentage increases:

- 1. scenario - an GDP increase of 2%
- 2. scenario - an increase of 1.7%
- 3. scenario - an increase of 2.7%
- 4. scenario - an increase of 2%

**Tab. 3: GDP in individual scenarios**

	<b>2010</b>	<b>1.scenario</b>	<b>2. scenario</b>	<b>3. scenario</b>	<b>4.scenario</b>
GDP in billion CZK	3775.24	3850.74174	3916.20435	4021.94187	4102.381

*Source: Own processing*

In particular scenarios we are working with percentage GDP increase, which are further used in relation to capital adequacy. Prognosis of the Czech National Bank counts in the first and fourth scenario with the same increase. This prediction has been

preserved, because the value entering into the calculation from the previous scenarios is different. The capital requirement thus varies according to each scenario. The resulting difference represents an increase of this requirement, which reduces GDP development by current value in various scenarios. By how much the capital requirement increases by such difference the GDP shall be deducted. In the simulation, there is created an interconnection, where the constant increase of demands for higher capital holdings causes a gradual reduction in performance of the economy.

**Tab. 4: The interrelation of capital requirement and GDP**

In millions of CZK	31.12.2010	1.scenario	2.scenario	3.scenario	4.scenario
Total capital requirement	128041	140845	147247	153649	160051
Regulatory capital	240429	240429	240429	240429	240429
The increase		12804	19206	25608	32010
The value of GDP in billion CZK	3775	3762	3756	3750	3743

*Source: Own processing*

To view the development we will use the calculated change in the illustrated charts.

**Fig. 2: GDP development**

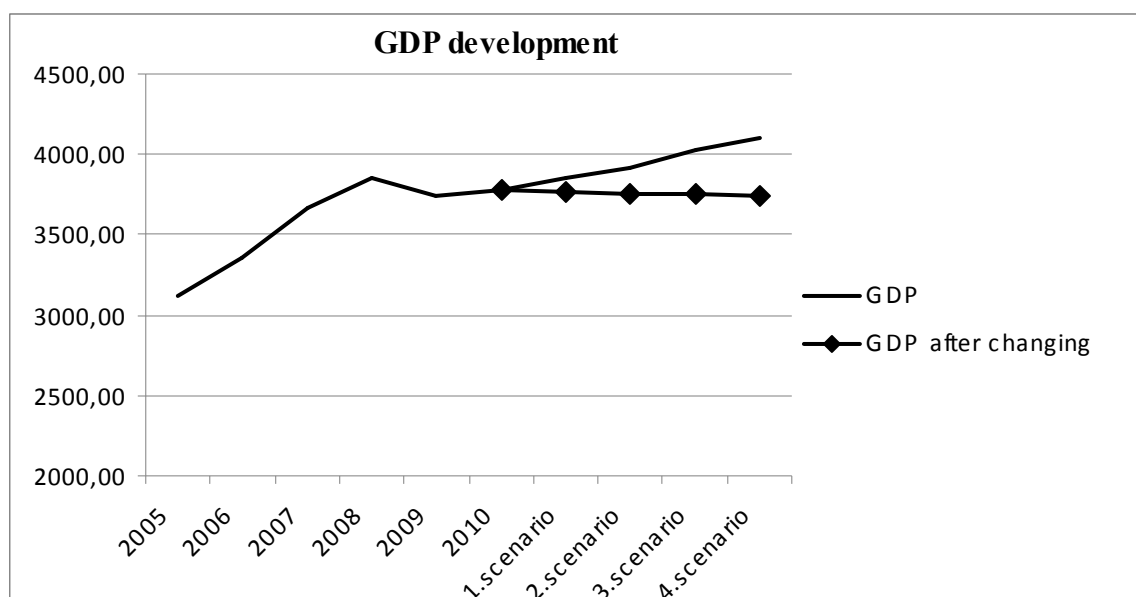

*Source: Own processing*

Despite the fact that in all four chosen scenarios, the 10% capital adequacy barrier was not broken the decisions of banks and the regulations may affect economic activity.

#### 4 Discussion

Banking regulation may cause a worsening of economic development. Possible effects of stricter regulation on the economic system are shown in Fig. 3.

*Fig. 3: Influence and impact of regulation*

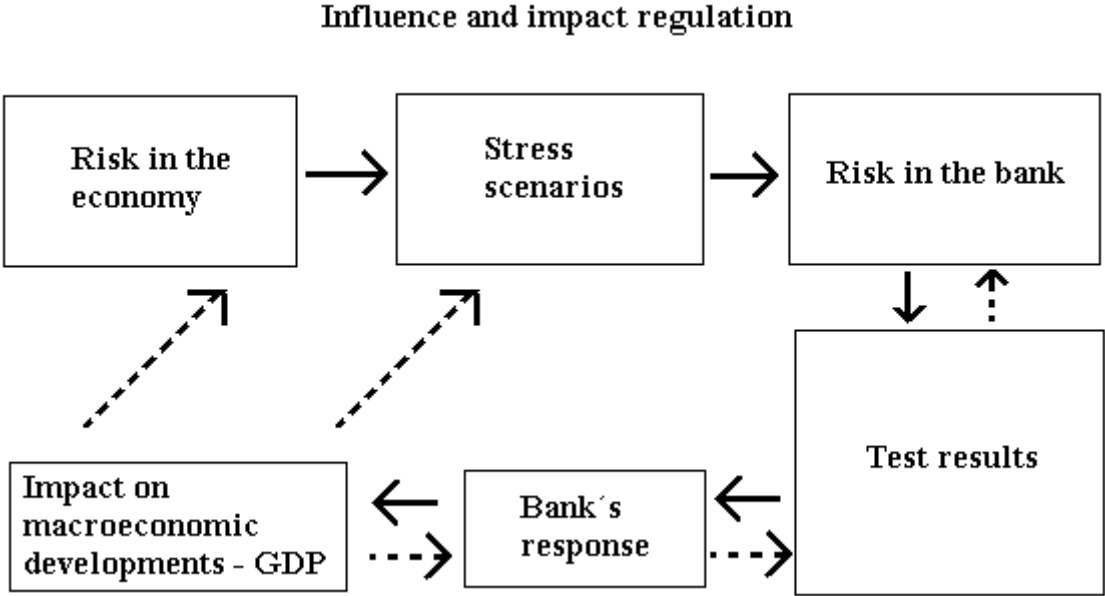

Source: [8]

According to the survey of Institute of International Finance, that brings together 400 international banks, rules of banking regulation known as Basel may take in 2015 up to 3 per cent of global economic growth. In Europe, this could lead during this period up to 5 million lost jobs and GDP growth slowed by 4.4 per cent during next 10 years. According to the study requirements for capital adequacy and liquidity, proposed bank taxes and other possible reforms, which are currently being discussed at the international level, could very hardly hit economic growth. Gross domestic product in the United States, Euro zone and Japan should every year until 2015 drop by an average of 0.6 per cent and in the long term view until 2020 by an average of 0.3 per cent, said the institute in a report.

According to McKinsey & Company study the proposed changes to the composition of Tier 1 are likely to cause a severe shortage of capital in the European banking of 700 billion. EUR, which represents a 40% increase in equity Tier I (core Tier I) and in case of adopting the proposed leverage ratio, grow of equity Tier 1 capital will be required by up to 70%. New standards for liquidity are likely to stand for an increase of long-term financing from 3.5 to 5.5 trillion EUR and banks will have to hold another 2 trillion CZK in highly liquid assets. The overall impact on European banks costs are estimated by the study up to 190 billion EUR including 40 billion EUR representing the effect of additional financing costs and 150 billion EUR of necessary costs to comply the proposed capital requirements. Basel III. proposals may result into ROE reduction of 5% (without minimizing effects the banking sector). Banks will

probably have to give up profits in 3 to 4 years. Basel III. rules implementation may have some other negative consequences for example on the interbank market, reduction of lending capacity by 1.2-2.5 trillion EUR and even decrease of the financial system stability. [6]

Ironically, even these enormous costs to increase the banking sector resistance through the growth of capital adequacy are not a guarantee of future stability, because there are many causes which may cause imbalances in the financial system. The basic causes of imbalances in the economic and banking system are listed in Fig. 4.

**Fig. 4: The root causes of imbalances in the economic and banking systems**

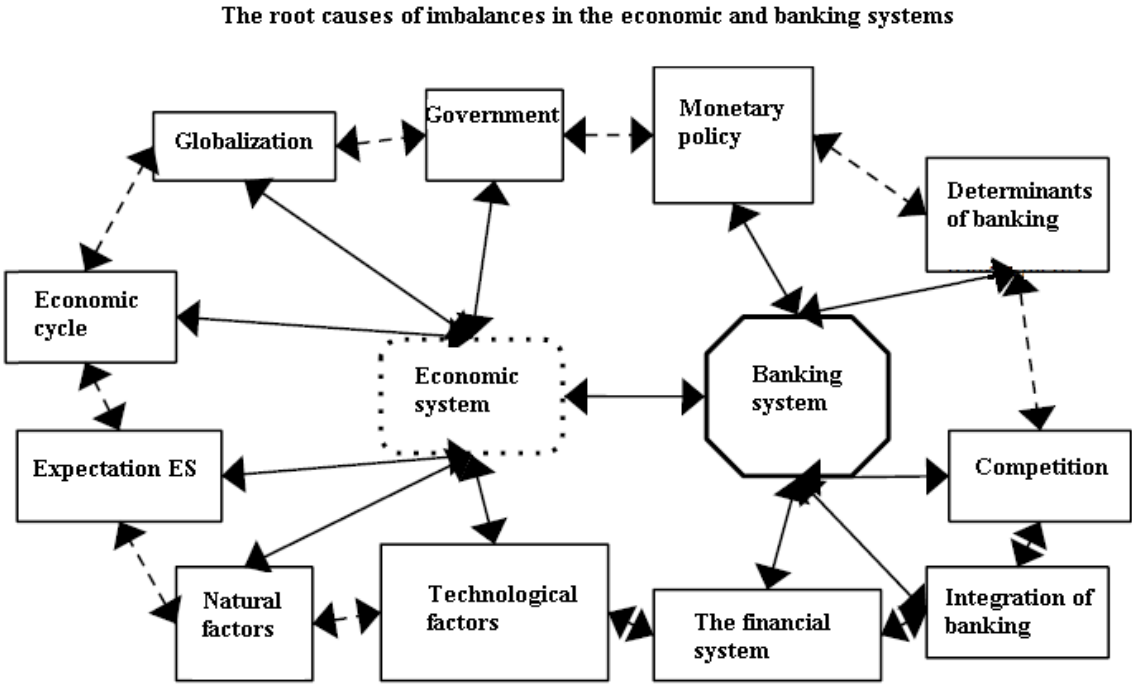

Source: [14]

System of factors that can cause imbalances in the banking sector is complex, complicated, non-quantifiable and very difficult to manage.

In the system is a very close link between economic and banking system, the intensity of these factors is not precisely quantified, is dynamic and often contradictory, which result into unique economic imbalances and inexistence of universal procedures to solve them.

Management of partial imbalances carriers is the responsibility of different authorities, there are market principles and forces that are largely self-regulating, moods and preferences of economic subjects cannot be controlled by anyone as well as for nature shocks. To solve imbalances doesn't exist and even cannot exist comprehensive scientific management methods. In some partial areas are different sophisticated solution that does not always bring the expected results (e.g., banking regulation), whereas efficient and at the same time simple solutions are often ignored (e.g. in excessive indebtedness of countries, companies or individuals).

The system has a variety of political, power and economic interests of prominent world economy countries like the U.S., Europe or China. [6]

The current situation in the capital adequacy of the Czech banking sector is quite favourable, because the sector currently has capital adequacy value, which will be mandatory since 2019.

Effects of the introduction of new and more stringent rules for capital adequacy in the banking sector of the Czech Republic will be minimal. Global risks for financial stability in the Czech Republic can be seen in the following areas: growing unemployment, high debt ratios private sector in Europe, tightening of financial conditions of the banks to households and enterprises, high degree of uncertainty in the financial markets, the development of domestic public finances and fundamental unsubstantiated appreciation of the Czech crown. [5] [12]

## **Conclusion**

The aim of this article was to analyse the relationship between stress testing of commercial banks and its impacts on the performance of the banking sector.

Regulation of the banking sector is primarily based on the calculation of risks and the determination of the minimum level of equity. In the article we use the basic methodology for calculating capital requirements for stress testing, adjusted by own scenarios of adverse shocks. The selected simulation was therefore composed using stress scenarios that dealt with increasing requirements for banks capital. Finding optimum equity is mainly influenced by excessive levels of regulation that may hinder the development potential of the financial and banking sector.

The results of our research have pointed to the possible pro-cyclicality of regulatory rules in the economic system, where increased capital requirement may cause a reduction in the value of GDP. In the simulation thus creates interconnectedness, where the constant increasing demands for higher capital holdings cause a gradual reduction in the performance of the economy.

The article also gives room for further discussion of the study area, where the lack of capital and weakened markets may compel the banks to sell rather better and healthier assets for which they get a fairer price than a weaker assets, of which will not be expressed sufficient interest. This can cause a drop in profitability, the need of follow-up capital increase, decreased willingness to provide new loans and thereby the reduction of economic activity of the entire market.

## **Acknowledgement**

This paper is one of the research output of the projekt IGA/Fame/2012/012: Optimization of internal rating model parameters of commercial banks in the small and medium enterprises.

## **References**

- [1] BABOUČEK, I. *Regulation of activity of banks*. 2009. Prague: Bankovní institut vysoká škola. 318 p. ISBN 978-80-7265-144-3.

- [2] BANK FOR INTERNATIONAL SETTLEMENTS. *Results of the Comprehensive quantitative impact study*. 2010. [cit. 12-03-28]. Available at WWW: <<http://www.bis.org/publ/bcbs186.pdf>>.
- [3] BANK FOR INTERNATIONAL SETTLEMENTS. *Group of Governors and Hrade of Supervision announces higher global minimum capital standards*. 2010. Basel. Press release.
- [4] BASEL COMMITTEE ON BANKING SUPERVISION. *Basel III: A global regulatory framework for more resilient banks and banking system*. 2010. Basel. ISBN 92-9197-859-0.
- [5] BASEL COMMITTEE ON BANKING SUPERVISION. *International framework for likvidity risk measurement, standards and monitoring*. 2009. Consultative Document. Basel. ISBN 92-9197-811-6.
- [6] BELÁS, J. et al. *New conditions for the international business of commercial banks*. Žilina: BEORG Žilina, 2011. 98 p. ISBN 978-80-89401-67-3.
- [7] CIPRA, T. *Capital adequacy in finance and solvency in the insurance industry*. 2002. Prague: Ekopress, s.r.o. ISBN 80-86119-54-8.
- [8] CZECH NATIONAL BANK. *Credit risk of CNB macro-stress tests*. 2011. [cit. 2012-04-10]. Available at WWW: <[http://www.cnb.cz/miranda2/export/sites/www.cnb.cz/cs/verejnost/pro\\_media/konference\\_projevy/vystoupeni\\_projevy/download/gersl\\_20111214\\_stress\\_testing.pdf](http://www.cnb.cz/miranda2/export/sites/www.cnb.cz/cs/verejnost/pro_media/konference_projevy/vystoupeni_projevy/download/gersl_20111214_stress_testing.pdf)>.
- [9] CZECH NATIONAL BANK. *Financial Stability Report 2010/2011*. 2012. [cit. 2011-04-02]. Available at WWW: <[http://www.cnb.cz/miranda2/export/sites/www.cnb.cz/cs/financni\\_stabilita/zpravy\\_fs/fs\\_2010-2011/fs\\_2010-2011\\_financni\\_sektor.pdf](http://www.cnb.cz/miranda2/export/sites/www.cnb.cz/cs/financni_stabilita/zpravy_fs/fs_2010-2011/fs_2010-2011_financni_sektor.pdf)>.
- [10] CZECH NATIONAL BANK. *Stress testing the banking sector in CR*. 2011. [cit. 2012-03-15]. Available at WWW: <[http://www.cnb.cz/miranda2/export/sites/www.cnb.cz/cs/financni\\_stabilita/zatezove\\_testy/2011/zatezove\\_testy\\_vysledky\\_2011\\_2q.pdf](http://www.cnb.cz/miranda2/export/sites/www.cnb.cz/cs/financni_stabilita/zatezove_testy/2011/zatezove_testy_vysledky_2011_2q.pdf)>.
- [11] CZECH NATIONAL BANK. *Verification of stress tests as part of an advanced stress testing framework*. 2010. [cit. 2012-04-05]. Available at WWW: <[http://www.cnb.cz/miranda2/export/sites/www.cnb.cz/cs/financni\\_stabilita/zpravy\\_fs/FS\\_2009-2010/FS\\_2009-2010\\_clanek\\_I.pdf](http://www.cnb.cz/miranda2/export/sites/www.cnb.cz/cs/financni_stabilita/zpravy_fs/FS_2009-2010/FS_2009-2010_clanek_I.pdf)>.
- [12] CZECH NATIONAL BANK. *Basel III: Impact on the Czech banking sector*. 2011. [cit. 2012-03-10]. Available at WWW:

<[http://www.cnb.cz/miranda2/export/sites/www.cnb.cz/cs/verejnost/pro\\_media/konference\\_projevy/vystoupeni\\_projevy/download/Tomsik\\_20110531\\_Basel\\_III.pdf](http://www.cnb.cz/miranda2/export/sites/www.cnb.cz/cs/verejnost/pro_media/konference_projevy/vystoupeni_projevy/download/Tomsik_20110531_Basel_III.pdf)>.

- [13] DVOŘÁK, Petr, 2005. *Banking for bankers and clients*. Prague: Linde Praha, a. s. 681 p. ISBN 80-7201-515-X.
- [14] HÄRLE, P., HEUSER, M., PFETSCH, S., POPPENSIEKER, T.: Basel III. What the draft proposals might mean for European banking. *Banking McKinsey & Company. Munich, April 2010*.
- [15] JÍLEK, J. *Financial risk*. 2000. Prague: Grada. 635 p. ISBN 80-7169-579-3.

### Contact Address

#### **Ing. Monika Garguláková**

Tomas Bata University in Zlin, Faculty of Management and Economics, Department of Finance and Accounting  
Mostní 5139, 760 01 Zlín  
Email: [gargulakova@cotesting.cz](mailto:gargulakova@cotesting.cz)  
Tel.: + 606388298

#### **doc. Ing. Jaroslav Belás, PhD.**

Tomas Bata University in Zlin, Faculty of Management and Economics, Department of Enterprise Economics  
Mostní 5139, 760 01 Zlín  
Email: [belas111@gmail.com](mailto:belas111@gmail.com)  
Tel.: +420576032410

Received: 27. 04. 2012

Reviewed: 13. 06. 2012

Approved for publication: 01. 11. 2012



# AN INSTITUTIONAL ANALYSIS OF BANK REGULATION

**Jakub Gleta, Petr Teplý**

**Abstract:** *This article focuses on the institutional content and impact of the new Basel Capital Accord, commonly known as Basel III. These rules were enacted in response to the recent developments in global financial markets and to introduce some substantial changes into established regulatory approaches. We use the method of “process tracing” of the neo-proceduralist school to assess whether Basel III is a victim of regulatory capture or not. We find that Basel III met a number of procedural requirements and is not a victim of regulatory capture. On the other hand, we point to the fact that there remain numerous open issues that could undermine the as yet unfinished outcome and cause Basel III to join its predecessors in their fate.*

**Keywords:** *Banking, Basel II, Basel III, Institutions, Neo-proceduralism, Banking regulation*

**JEL Classification :** *G21, G28.*

## **Introduction**

Banking regulation has been blamed to have a share on the 2007-2009 global crisis. Banks failed to maintain sufficient capital buffers to absorb the losses and to prevent them from running risky operations that are incompatible with financial stability and the privileged role of banks as routers and transformers of capital flows in the economy [18]. In this paper, one of the most important regulatory reforms adopted lately is discussed. The third version of Basel Capital Accords, commonly known as Basel III ([1], [2], [3] and [4]), is presented and analyzed from the institutional point of view. This reform proposal, drafted and adopted in record time, introduces some revolutionary changes into banking regulation. Its impact is, however, far from clear - especially liquidity proposals are subject to a lot of critique and uncertainty both on the part of the industry and national supervisors.

Using the method of process-tracing, we examine Basel III enactment process and find that it is not a victim of regulatory capture, as opposed to its predecessor. On the other hand, we find that new rules will likely be watered down due to the lengthy transitional period and the fact that a significant portion of provisions are subject to supervisory review process over the years. This contributes to our final assertion that although a step in the direction, Basel III will fail to meet its objectives due to reasons outlined herein.

The paper is organized as follows. In the second part, we present the paper by Lall [14] that serves as the departing point for our analysis. We believe that understanding the institutional context of the environment in which regulation is drafted and adopted, together with implications for the behaviour of market participants, is of utmost importance. To this end, we try to extend the Lall's work until present time. We find that Basel III represents a significant improvement in terms of regulatory capture,

compared to Basel II. After that, we discuss in Section 3 some challenges faced by the Basel Committee on Banking Supervision that could further undermine regulatory efforts. Section 4 concludes the paper.

## **1 Analysis of Basel II**

In his seminal paper [14], Lall argues that the primary cause of the failure of Basel II lies in regulatory capture of regulatory agencies by regulated institutions. In short, he argues, Basel II is a prime example of regulatory capture. Large international banks were able to systematically manipulate the process and outcomes of Basel II, effectively transferring wealth to themselves at the expense of their smaller competitors and, above all, the society and systemic financial stability [16, p. 10]. Basel II hence failed to attain its declared objectives of promoting safety and soundness in financial sector, constituting a more comprehensive approach to risk management and promoting competitive equality in the sector.

Departing point for his analysis is the neo-proceduralist approach to regulation, developed recently by Walter Mattli and Ngaire Woods [16, p. 10]. It has much in common with the emerging field of global administrative law, which represents the core of the proceduralist approach to global regulation [13]. These scholars identify public interest with a certain type of due process that meets certain standards [14, p. 10]. As Mattli and Woods put it, “regulation is said to be in the public interest if it is arrived at through a deliberation process that allows everyone likely to be affected by it to have a voice in its formation” [16, p. 13].

Nevertheless, similarities with proceduralists end here. Mattli and Woods discard the idea that improvements on the institutional side alone are sufficient to secure optimal, common interest regulation. Neo-proceduralists emphasize two types of conditions that must be met to produce the optimal result. The first are the so-called supply side conditions, concerning the institutional conditions in which any regulation is being drafted and implemented, and the demand side conditions encompassing the extent and intensity of societal pressure for efficient and effective regulation. In their opinion, these demand side conditions make the difference. They argue that, first, constituencies adversely affected by regulatory status quo must be aware of and have proper information about the social cost of capture and international regulatory agenda. Where large market players have information monopoly, it is likely that they reach their preferred outcomes at the expense of the less-informed. Second, these constituencies must be supported by public or private agents that facilitate technical expertise, financial resources and an organizational platform for them. Finally, and crucially for the success of these alliances, is a shared set of ideas about how to regulate that serves as a departing point in deliberations [14, p. 10].

To clarify the approach, let us distinguish between regulatory change that serves vested interests of a narrow group and that beneficial for the whole society. Mattli and Woods draw up broad conditions under which different outcomes are expected to occur in international regulatory framework, indicating a plausible set of hypotheses about the factors facilitating capture in regulatory process [14, p. 9]. To be able to tell when one outcome is more likely than the other, they argue, we must assess the ‘supply-side’ institutional context in which new regulation is prepared, implemented

and enforced [14, p. 10] . An ‘extensive’ institutional context, characterized by open forums for debates, multiple-stakeholder and proper oversight, is less likely to produce outcomes that serve one particular interest group and which shows signs of being captured than a ‘limited’ context that is exclusive, closed and secretive [14]. It is only when both supply and the aforementioned demand conditions are met, however, that the process can generate desired results – a claim made by Mattli and Woods that extends the original proceduralist approach. A mere extensive forum without wider societal input in the form of desire for change is not enough, in their opinion. In addition to that, constituencies affected by the change must have proper information. This can be labelled as an attempt to bring politics back into proceduralism - regulatory outcomes are thus defined not only in terms of the procedure that generates them but also by the range of societal input into it ([14], p. 10).

### **1.1 Temporal contextualization**

By identifying an important condition for the regulatory process to produce desired results, Mattli and Woods have made a significant step forward in the study of international regulatory process. Nevertheless, as Lall argues, they have failed to account for a key variable that influences the outcome in their comparative-static analysis – the temporal dimension. As Lall puts it, we must conceive of regulatory capture as a cumulative, gradual process that unfolds over time. Recognizing that processes and their outcomes are rooted in a particular temporal context enables us to notice key causal effects and draw conclusions that we would not be able to see or make from an ahistorical, snapshot perspective [17].

The benefit we gain from extending the framework over time is enormous. By recognizing that regulatory process unfolds over time we get a better understanding of how agents with informational advantage may turn this into specific regulatory outcomes. In particular, these actors can claim a ‘first-mover advantage’ – they are able to arrive at the decision-making table first and employ significant leverage in later stages, since decisions made early tend to be self-reinforcing [14, p. 12]. As Paul Pierson argues, “If early competitive advantages may be self-reinforcing, then relative timing may have enormous implications...groups able to consolidate early advantages may achieve enduring superiority” [17, p. 71].

Lall [14] further extends this argument by adding that early participation matters only if negotiators have little or none accountability to domestic constituencies. That is, in a limited institutional context where decisions do not have to be endorsed by domestic bodies such as parliament, regulator or other similar bodies. Clearly, when an agreement is to be endorsed by a wide domestic constituency, a first-mover advantage does not facilitate outcomes desired by the interest group having it. In this context, Lall argues, the framework allows us to expect that banks arriving first at negotiations of Basel II were able to gain significant first-mover advantage and shape decisions in a way that was favourable for them, and at the same time, increasingly more difficult to change in later stages. He further argues that “the question of who arrives first is not a matter of chance, but a function of the distribution of information among actors” [14, p. 12]. Clearly, large international banks had to be the best informed, given their wide scope of actions and a global network. Moreover, informal connections play

an enormously important role. Again, large international banks had the best informal connections to their benefit and utilized this privileged status during the Basel II process to a large extent.

## **1.2 Basel II outcomes**

Ranjit Lall uses a method he calls ‘process-tracing’ to identify key points when regulators made concessions to large international banks and, in doing so, have jeopardized the stability of the financial system. He examines and compares closely various press releases, statements, official documents and interview transcripts to assess whether there is evidence for his hypothesis that the Basel Committee on Banking Supervision (BCBS), and Basel II as a consequence, was captured by large international banks.;

He starts by identifying BCBS to have “*one of the worst records of all international standard-setters in terms of transparency, representation and accountability. The Committee’s meetings, which occur four times a year, are closed to the public, with no record of who was present or what was discussed.*” [14, p. 12]. BCBS further breaks down into four policy groups in charge of fourteen subcommittees, where most of the technical work is done, usually in close cooperation with industry experts. We have no illusions as to which institutions these experts come from and in whose interest they act. Seen from the outside, BCBS is a rather opaque institution that is not accountable to any national or supranational body, the European Commission (EC) and European Central Bank (ECB) having only an observer status. BCBS is only accountable to a group of G-10 central bank governors and among these, only a few are responsible for banking regulation in their home country [14, p. 13].

### ***Extension of the analysis***

The prospects presented by Mr. Lall seem very grim. In this section, we will apply his methodology and extend the analysis by current events trying to find evidence for his hypothesis that Basel III will be yet another case of regulatory capture. In doing so, we gathered information from various publicly available sources, such as the Risk magazine, Financial Times or Reuters, as well as compare and analyze the individual stages of Basel III reform proposals to see if there is evidence in favour or against the hypothesis. In our opinion, it can give us a very valuable insight into the problematic of regulatory capture, how it evolves over time, what are its symptoms and what repercussions it may have in future.

## **1.3 Basel III evolution**

Let us examine the wording of Basel III per se and how it evolved over time. As has been mentioned before, BCBS has published a preliminary version on Basel III in December 2009 [1], subject to comments until April 2010 and released in July 2010 [2], with final version made public in December 2010 [3 and 4]. We shall now turn our attention to the time interval between April and December 2010 to see if, and how, effective individual lobbying groups were at influencing the Committee, and find evidence for or against the hypothesis that Basel III is an example of regulatory capture.

## 1.4 Capital, capital ratios and counterparty credit risk

In general, the Committee retained most of the proposals set out in December 2009. There have been, however, certain concessions made to the definition of capital. As the Committee put it, “certain deductions could have potentially adverse consequences for particular business models and provisioning practices, and may not appropriately take into account evidence of realisable valuations during periods of extreme stress” [2]. The Committee allowed for partial recognition of minority interest supporting the risk of a subsidiary that is a bank. This means that banks that report minority interest of a party on their consolidated balance sheets can deduct that portion of capital required by the regulator attributable to the minority party from their capital requirement, in proportion to the minority share.

In addition to minority interest, the Committee has also announced changes to the treatment of:

- Deferred tax assets (DTA) that arise from timing differences,
- significant investments (more than 10% of the issued share capital) in unconsolidated financial institutions; and
- mortgage servicing rights (MSR).

Instead of a full deduction, these items receive a limited recognition capped at 10% of bank’s common equity for each item and 15% aggregate over the items. The amount that by which the sum of the three exceeds 15% must be deducted from bank’s Common Equity Tier 1 (CET1).

Formerly, DTA could rely on estimates of future profitability of a bank. In Basel III, DTA will be recognized only if they stem from timing differences, such as allowances for credit losses. All other assets that could be carried forward as unused tax losses or tax credits will be deducted in full from CET1. The decision to remove DTA in their previous form from CET1 capital is certainly a step in the right direction. Nevertheless, in our opinion, retaining them even in a limited scope is at odds with prudential regulation. DTA are by definition not readily available for loss absorption. Recognition of DTA in its current form is based on the notion of postponed cash realization. Hence, for the bank to make use of DTA, it must wait until cash inflow occurs, which takes too long a time in period of distress and therefore cannot contribute to loss absorption. In our opinion, DTA should be moved to Tier 2 capital, if not eliminated from regulatory capital altogether.

The question of mortgage servicing rights is particularly important for US banks. MSR represent a contractual agreement between the mortgage lender and the servicing entity that performs all servicing functions, i.e. collects payments and distributes interest and principal repayments, taxes etc. The market for MSR is a multi-billion industry in the USA and they have represented a significant portion of banks’ income prior to the crisis.

The problem with MSR is that they are very difficult, if not impossible, to attach a reasonable value to. There exists no liquid market for MSR, being traded solely over-the-counter (OTC). Banks can essentially attach any value to them. This depends on the creditworthiness of mortgage borrower, open market value of collateral property, the willingness to refinance when interest rates decline and many other factors that are

difficult to predict. The regulator has therefore no reliable clue to confront bank's estimates of MSR value with economic reality. MSR retention on the list of eligible capital instruments can therefore be viewed as a concession to US banks that use them to enhance their capital position.

## **1.5 Leverage ratio**

Leverage ratio has been watered down rather significantly. Initial proposals have been met with strong opposition from the industry, calling it redundant, insensitive to different business models and excessive. Despite this critique, BCBS retained leverage ratio in final version of Basel III, although some concessions have been made along the way. The most important is timing. Leverage ratio will enter into an observation period, starting January 2011, when supervisors will develop tools to track and evaluate the ratio. The parallel run period commences January 2013 and runs until January 2017. During this time, the Committee will closely monitor the behaviour of the leverage ratio in relation to other regulatory measures. Based on the results from the parallel run period, the Committee will make final adjustments to it in the first half of 2017, *“with a view to migrating to a Pillar 1 treatment in January 2018, based on appropriate review and calibration”* [3, p. 63]. In our opinion, this prolonged review and calibration period will contribute to leverage ratio not being binding, or being significantly diluted in the end. Seven years is a long period – many things can change and banks can exert quiet but steady pressure on the Committee to change the rules to their benefit. The Institute of International Finance (IIF) lobbied for the ratio to be implemented as a part of Pillar II guidance, being at national supervisors' discretion [5]. Concessions made to implementation timing are suggestive of partially successful lobbying from the industry.

## **1.6 Liquidity measures**

Liquidity measures have also experienced changes during 2010. These can be divided into three categories. First, certain adjustments have been made to numerical values of run-off rates, availability and required factors for stable funding calculation and haircuts to market values of assets in the stock of liquid assets. These are quite noticeable in some instances, such as lowering the minimum required credit rating for some assets held in the stock of liquid assets. On the other hand, the definition of Level 1 assets is now more limiting than in the original proposal.

Second, original proposal contained no distinction between Level 1 and Level 2 liquid assets. The final proposal adds this division, reflecting the industry's call for a wider scope of eligible assets. Given our current state of knowledge, the judgment whether this division is an example of regulatory capture would amount to pure speculation.

Third, the timeline of implementation and observation period commences in January 2012 for both standards. Any revisions to the Liquidity Coverage Ratio (LCR) must be made until mid-2013. LCR will be introduced in January 2015, including any revisions. Net Stable Funding Ratio (NSFR) can undergo changes until mid-2016, being enforceable as a minimum standard from January 2018. Again, as in the case of leverage ratio, the industry has succeeded in postponing the binding power of liquidity

ratios until well into the future. This can give banks enough space to influence the Committee and try to influence the final shape of regulation.

## 1.7 Timeline of implementation

In our opinion, concessions made to the timeline of implementation of changes introduced by Basel III are the most serious among the dilutions made to Basel II. In effect, despite the fact that final version of Basel III contains most of the originally proposed measures, the desired effect can be watered down as a result of a very long transition period. As Stephen Green, chairman of HSBC, said at the end of consultation period in April 2010, *“changes should be gradually phased in over several years and must be internationally co-ordinated”* [5].

The following G-20 meeting in Toronto in June acknowledged delays in implementation timeline. The original plan was that the talks would be completed by the end of 2010 and new rules would be enforceable by the end of 2012. Hopes for a swift and timely implementation were put to rest when Canadian finance minister James Flaherty announced major postponements of implementation deadlines, saying that *“there can be a compromise on that”* [7]. George Osborne, the Chancellor of the Exchequer, said at the very same meeting that he is prepared to bear some delay, provided that there are no attempts at diluting the accord. With troubles heaping in the Eurozone, French and German banks were in favour of up to 10-year transitional period, in connection with their reliance on hybrid capital instruments that were scrapped by Basel III and which have to be refinanced by some form of Tier 1 capital upon maturity [7].

A few days later, Nout Wellink, chairman of BCBS, said at the meeting organized by IIF that *“where there are trade-offs, these should go in the direction of giving banks the time to reach the new standards instead of watering down the standards themselves”* and *“we do realize, on the basis of quoted impact studies, that we have to compromise on certain elements...but I think we will find a very acceptable solution”* [8]. Mr. Wellink further stated that regulators will also *“take into account the impact on the economy so as not to hamper the recovery,”* but there is no doubt that *“major part of the banking sector will go through a difficult period”* [9]. Praise from the sector was heard, stating that regulators *“have gone for the pragmatic outcome in which they recognize that they need a long glide path,”* [10] together with warm embrace of a wider capital definition and easements to some critical definitions concerning liquid assets. Timothy Geithner, US Treasury secretary, said at a conference in New York in August 2010 that *“We know [capital ratios] need to be substantially higher than they were. But we also know that if we set them too high too fast, we could hurt economic recovery or simply end up pushing risk outside of the banking system – something that could ultimately come back to haunt us. To limit that potential, we plan to give banks a reasonable transition period”* [19]. But in general, there is a consensus that Basel III has achieved most of what it originally set for, at least in the initial phase of the process – *“We went out with an initial proposal that was very conservative and have naturally made some adjustments as part of the normal consultative process. But when people step back and look at the whole package in comparison with the current status quo, they will see this is a major rising of the*

*bar in terms of capital and liquidity,*” Stefan Walter, secretary general of BCBS, said [19]. What remains to be done is the actual implementation, where the risk of watering the final effect down is anything but negligible.

## **1.8 Summary of Basel III process achievements**

When we take a big picture of the Basel III process so far, there are salient distinctions from that of Basel II. The biggest one is the extent and intensity of political pressure exerted on the Committee. In reaction to recent crisis, G-20 and Financial Stability Board (FSB) have been the key international players that influenced the shape of new regulation. Times when politicians were mere observers of the decision-making process at the Committee seem to be gone. The Committee had to obey a mandate set by G-20 in successive communiqués since April 2009, which made a number of people at the Committee, who were accustomed to a more secretive and much slower *modus operandi*, very uncomfortable.

Basel II was being completed over a few years. It seems almost unbelievable that Basel III has been completed in a year, given the scope of changes made to the framework. On the other hand, we have to acknowledge that this rush could cause a number of imperfections or measures that can manifest themselves as inappropriate or ill-fitted. As one senior Committee member put it, *“We have been pushed very hard by politicians to rush, so very often we have not been able to complete our assessment of all the changes, and the economic and financial situation is still very difficult. That means the old way of working hasn't been appropriate, and because of the pressure to complete, the secretariat has had to be very strong, even if some countries resisted”* [19]. This could be seen in July, when Germany refused to sign changes endorsed by the Committee to the initial proposal until the calibration and transitional arrangements had been completed.

When we evaluate Basel III process from the neo-proceduralist point of view, we have to acknowledge that it fulfils the requirements proposed by Mr. Lall to a large extent. First, supply side conditions were largely fulfilled with the extension of BCBS to encompass members from 27 countries, represented by no less than 45 institutions [19]. The Committee was pushed to open itself much more to the public. Bankers were blamed for the crisis and politicians throughout the world took advantage of this public anger to take more decisive steps in their attitude toward the banking sector. As has been stated above, it was G-20 that initiated Basel II reform and subsequently overlooked the process. Without this globalized political pressure on the Committee, we doubt Basel III to be adopted as fast and the changes to be as deep. In effect, the Committee was an extensive forum, with changes being approved by an external authority (G-20). In this setup, the effect of early arrival at the decision-making table does not constitute a comparative advantage. Even if an interest group had a privileged and early access and could influence the process to its benefit, it could not expect that decisions made at an early stage will not be revoked later.

Second, and more importantly, demand side conditions were much better than during the Basel II process. Bankers stood at the forefront when culprits of the crisis were being identified. Reform proposals concentrated on the banking sector, both due to the substantiality of the need for reform, and public pressure. To use the terms of



neo-proceduralists, wide constituencies were aware and well-informed about the causes and costs of the crisis. Moreover, the public was supported by supervisory bodies and other public agencies in their calls for a deep and substantial change to the way banking sector operates. This unison is unprecedented and we identify it with two facts, the degree of globalization of banking business and the ease of access to reliable sources of information.

To summarize, the conditions for a process to fall victim of regulatory capture were largely not fulfilled in the case of Basel II. Despite certain imperfections and concessions outlined herein, we argue that, in general, the process achieved the desired results to a large extent. Therefore, we reject our hypothesis that Basel III is another example of regulatory capture due to the reasons stated above. Finding that Basel III has not been captured, however, by no means do we imply that this cannot happen in future, when public attention diverges from banking regulation and banks will again have a lot of time to lobby during the very long implementation period, when significant dilution can take place. This long implementation period is, in our opinion, the most vulnerable point in Basel III framework, as we further argue below.

## **2 What remains to be done**

As successful in reaching the goals originally set as Basel III may seem to be, there still remain a number of open issues, some of which can potentially cause a salient threat to the desired outcomes. We shall now examine some of them and evaluate their potential adverse impact onto regulatory process. First and foremost, the question of actual implementation arises. There are two dimensions to that; time and consistency. Considering the timeline of implementation, there are open issues with regard to liquidity ratios and the leverage ratio - the Committee has only set dates by which certain landmarks are to be achieved. There is still a lot of uncertainty about the actual shape of the process and development both within the Committee and the industry itself. These new regulatory instruments were adopted in a very short time span and hence can entail major unintended and unpredicted consequences.

Second, the Committee based its predictions and calculations on the assumption that Basel III is implemented at the same time and consistently throughout its jurisdictions. This assumption might be rather daring, since the actual process of implementation can result in a much less degree of consistency than the Committee would wish to achieve. National legislators and regulatory bodies must now transpose the rules into their own legal systems, which can cause a good deal of delay and cause a knock-on effect in postponing the deadlines. Regulators and the industry are well aware of this fact – *“I certainly think the hard work on this starts now. Politicians have said this is a prime opportunity to get consistency of capital and liquidity rules across all countries, but that will be very difficult to achieve. The countries may have all signed up at a broad level, but whether they implement consistently will be the real challenge”* Pamela Walkden of the London’s Standard Chartered said [20].

Third, there is an imminent risk that a major banking jurisdiction delays significantly with the implementation. The USA has recently adopted their own extensive financial reform, known as the Dodd-Frank Act. This piece of legislation puts an enormous deal of requirements on US banks and there are concerns whether

these will have sufficient capacity to absorb Basel III. We can be sure to expect that US banks will first strive to conform to their home regulation, before being concerned with Basel III. As one senior European regulator put it, *“If the US does not implement it, Basel III will fail. I fear more the US not implementing Basel III than Europe or the emerging markets. If US banks don’t have to implement it, the European banks will lobby they are at a competitive disadvantage. If banks lobby for years and years, I’m not sure we would be able to resist”* [20].

However, there are also open issues that remain to be resolved in the near future. The Committee has expressed the desire to add a capital surcharge for the so-called systemically important financial institutions (SIFI) to account for the additional risk they pose. The industry did not hesitate to issue a warning that this could lead to even more severe curb in lending activity and, hence, economic growth. In addition to capital surcharges, regulators are trying to figure out a failure resolution scheme in case a major global bank failed, without the enormous costs to taxpayers witnessed recently. IIF did not lose time to present its own proposal in January, in a fashion akin to the practice observed during Basel II creation when it was the industry that was setting the agenda. It came in a time when there are divergent plans on how to treat SIFIs among global players. This pre-emptive action came immediately after it had become obvious that a resolution scheme of kind or the other is more or less inevitable. We could argue that they changed their minds because alternatives offered by sticking to refusing any additional requirements could be worse in the end.

Regulators, however, differ substantially in their approach to SIFI treatment. There is no international coordination on this topic whatsoever. FSB presented a paper in November 2010 at the G-20 summit in Seoul containing various measures, such as capital surcharges, contingent or bail-in capital and additional liquidity requirements. Switzerland plans to impose additional capital charges on its two largest banks, UBS and Credit Suisse, that would contain some hybrid instruments currently not treated in Basel III. National regulators are presenting their own, conflicting ways to address the topic and so far, there has not been any major breakthrough agreement.

As far-reaching and successful in addressing the problems surfaced during the latest crisis as Basel III is in our opinion, there are a number of issues that remain to be addressed and resolved in a timely fashion to avoid dilution or evasion of some proposals, preventing a regulatory failure akin to that of Basel II. We argue that the timeline of implementation and unresolved issues concerning liquidity standards and treatment of SIFIs can pose a serious risk to Basel III being successful in the end. This risk is very material and politicians should remain alert about further regulatory agenda to prevent interest groups from capturing the Committee, after financial regulation has retreated from prominence in political agenda in the months and years to come.

## **Conclusion**

This article was devoted to the institutional assessment of new capital adequacy rules commonly known as Basel III. These react to recent global financial crisis and ensuing recession that uncovered serious flaws in regulatory approach that failed to

account for most serious sources of risk. Banking sector was the originator of some of the most salient problems and Basel III aims to prevent this from happening again.

We adopt the neo-proceduralist approach to regulation assessment put forth by Ranjit Lall who uses a method of “process-tracing” to analyze regulatory process from the regulatory capture point of view. Based on that, we find that Basel III has successfully evaded the fate of its predecessor and is not a victim of regulatory capture. On the other hand, as we argue further, Basel III can once again fail to meet its objectives, if it is watered down by the affected institutions during the lengthy transitional period.

Finally, we focus on the challenges that remain to be faced by regulators. In particular, we point to the problem of systemically important financial institutions and consistency of implementation across jurisdictions. We argue that failure to resolve these issues can jeopardize regulatory reforms and stability and soundness of global financial markets.

Politicians and the society in general should remain alert to further developments in regulatory agenda. Banking sector has shown immense ingenuity at lobbying for more favourable rules in the past, always at the expense of the society as a whole. Therefore, it is of utmost importance for us to remain observant of regulatory agenda once banking regulation retreats from global flashlights.

## Acknowledgement

Financial support from The Czech Science Foundation (projects under No. GA 403/10/P278 - The Implications of The Global Crisis on Economic Capital Management of Financial Institutions and No. GA P403/10/1235 - The Institutional Responses to Financial Market Failures), and The Research Institutional Framework Task IES (2005-2010 - Integration of The Czech Economy into The European Union, and The Grant Agency of Charles University (GAUK 58410/2010 - Efficiency of EU Merger Control) is gratefully acknowledged.

## References

- [1] BCBS. *Strengthening the Resilience of the Banking Sector*. [cit. 2012-02-25]. Available from WWW: <<http://www.bis.org/publ/bcbs164.pdf>>.
- [2] BCBS. *The Group of Governors and Heads of Supervision Reach Broad Agreement on Basel Committee Capital and Liquidity Reform Package*. [cit. 2012-02-25]. Available from WWW: <<http://www.bis.org/press/p100726/annex.pdf>>.
- [3] BCBS. *Basel III: A Global Regulatory Framework For More Resilient Banks and Banking Systems*. [cit. 2012-02-25]. Available from WWW: <<http://www.bis.org/publ/bcbs189.pdf>>.
- [4] BCBS. *Basel III: International Framework for Liquidity Risk Measurement, Standards and Monitoring*. [cit. 2012-02-25]. Available from WWW: <<http://www.bis.org/publ/bcbs188.pdf>>.
- [5] JENKINS, P., MASTERS, B. *Financials seek to soften Basel stance*. [cit. 2012-02-25]. Available from WWW: <<http://www.ft.com/cms/s/0/7b6fe3b0-4587-11df-9e46-00144feab49a.html#axzz1rF8tNEtB>>.

- [6] MASTERS, B. *Intesa chief calls for clear rules*. [cit. 2012-02-25]. Available from WWW: <<http://www.ft.com/intl/cms/s/0/b149148e-66ca-11df-aeb1-00144feab49a.html#axzz1rF8tNEtB>>.
- [7] ELLIOT, L. *G20 delay on Basel III bank curbs*. [cit. 2012-02-25]. Available from WWW: <<http://www.guardian.co.uk/world/2010/jun/04/financial-crisis-basel-bank-curbs-delay>>.
- [8] FINANCIAL TIMES. (2010d). "Banks are to get more time to implement new capital rule." *Financial Times*, June 11.
- [9] FINANCIAL TIMES. (2010e). "Basel chief points to reform benefits." *Financial Times*, June 12.
- [10] MASTERS, B. *Bank regulators reach deal on liquidity*. [cit. 2012-02-25]. Available from WWW: <<http://www.ft.com/intl/cms/s/0/6d4e261c-98e7-11df-9418-00144feab49a.html#axzz1rF8tNEtB>>.
- [11] CHRIS, G. *Is Basel III just like tightening monetary policy?* [cit. 2012-02-25]. Available from WWW: <<http://blogs.ft.com/money-supply/2010/09/13/is-basel-iii-just-like-tightening-monetary-policy/?axzz1rFDCU1iw>>.
- [12] ALLOWAY, T. *CDS options market multiplies alongside questions*. [cit. 2012-02-25]. Available from WWW: <<http://ftalphaville.ft.com/blog/2011/03/28/528141/cds-options-market-multiplies-alongside-questions/>>.
- [13] KINGSBURY, B, KRISCH N. and SEWART, R. The Emergence of Global Administrative Law. *In Law and Contemporary Problems*, 2005, Vol. 68, Iss. 15, pp. 15-61. ISSN: 0023-9186
- [14] LALL, R. *Why Basel II Failed and Why Any Basel III is Doomed*. [cit. 2012-02-25]. Available from WWW: <<http://www.globaleconomicgovernance.org/wp-content/uploads/GEG-Working-paper-Ranjit-Lall.pdf/>>.
- [15] LALL, R. *Reforming Global Banking Rules: Back to the Future?* [cit. 2012-02-25]. Available from WWW: <<http://www.diis.dk/graphics/Publications/WP2010/WP2010-16-Lall-Reforming-global-banking-rules.pdf>>.
- [16] MATTLI, W., WOODS, N. *The Politics of Global Regulation*. Princeton: Princeton University Press, 2010, 312 pp. ISBN 9780691139616
- [17] PIERSON, P. *Politics in Time*. Princeton: Princeton University Press, 2004, 196 pp. ISBN 0-961-11715-2.
- [18] REINHARDT C.M., ROGOFF, R. *This Time Is Different: Eight Centuries of Financial Folly*. Princeton: Princeton University Press, 2009, 443 pp. ISBN 978-0691-14216-6.
- [19] CLARK, J. A crucial month for Basel III calibration. [cit. 2012-02-25]. Available from WWW: <<http://www.risk.net/risk-magazine/feature/1730685/a-crucial-basel-iii-calibration>>.
- [20] CLARK, J. *The end of the beginning for Basel III*. [cit. 2012-02-25]. Available from WWW: <<http://www.risk.net/risk-magazine/feature/1899819/beginning-basel-iii>>.

## **Contact Address**

### **Mgr. Jakub Gleta**

Charles University in Prague, Faculty of Social Science, Institute of Economic Studies  
Opletalova 26, 110 00 Praha 1

Email: jakub.gleta@gmail.com

tel. č.: +420 222 112 305

### **PhDr. Petr Teplý, Ph.D.**

Charles University in Prague, Faculty of Social Science, Institute of Economic Studies  
University of Economics in Prague, Faculty of Finance and Accounting

Opletalova 26, 110 00 Praha 1

Email: teply@fsv.cuni.cz

tel. č.: +420 222 112 320

Received: 28. 09. 2011

Reviewed: 01. 02. 2012

Approved for publication: 03. 05. 2012

# FINANCIAL HEALTH AND THE COST OF CAPITAL OF TRAVEL AGENCIES BEFORE AND AFTER THE CRISIS

Irena Honková

**Abstract:** *This Article deals with the evaluation of the economic crisis in the area of travel agencies. The evaluation was based on the Altman Z-score of financial health and the weighted average cost of capital (WACC). Data presented in 2007-2010 financial reports compiled by selected companies were also employed. Using the signed-rank test the hypothesis the impact of the financial crisis on the financial health of selected companies was examined. The same test was applied to the weighted average cost of capital. Furthermore, dependencies between financial health and the weighted average cost of capital during individual years in concern were investigated. This dependency was tested by means of Spearman coefficient, determination index a correlation coefficient. According to the tests of statistical hypotheses the companies were not affected by a lower Altman Z-score during the crisis; i.e. Their performance was not worse than before the crisis. The impact of the crisis on the weighted average cost of capital was not proven either. Dependency between both indicators (the Altman Z-score and the weighted average cost of capital) was not established. The aim of this Article was to evaluate the impact of the financial crisis and to find possible dependency between stability (represented by the Altman Z-score) and the weighted average cost of capital. It was ascertained that the financial crisis did not have any significant influence on the financial performance of the selected companies. Dependency between the two indicators discussed above was not proven either.*

**Keywords:** *Altman Z-score, Weighted average costs of capital, Economic crisis, Signed-rank test, Spearman coefficient, Determination index, Correlation coefficient*

**JEL Classification:** *M21.*

## Introduction

This Article evaluates the impact of the global economic crisis on the financial aspects of Czech companies falling within the branch of travel agencies. Travel agencies are characterized with specific financial issues owing to which they are obliged to take out statutory bankruptcy insurance against. Therefore, these companies were more likely to be susceptible to financial problems due to the economic crisis than entities operating in more stable branches. Their financial difficulties result in a change in funding conditions; specifically in worse accessibility of third parties' funds and thus in the necessity to use the companies' own, more expensive funds. In order to be able to monitor comparable financial sources, the main criterion for selecting companies was their legal form; i.e. joint-stock companies since these companies can be financed by both stocks and external equity capital.

## **2 Statement of a problem**

Two indicators were used to monitor the impact of the crises. These indicators were the Altman Z-score and the weighted average cost of capital (WACC). The Z-score, being a composite financial analysis indicator, offers principal financial characteristics and provides a suitable tool for determining the financial standing of a company. The weighted average cost of capital take into account the capital structure as well as the percentile cost of capital per a unit of capital. The main asset of this indicator is the fact it includes not only the cost of foreign capital, but also the cost of own capital equity capital. This cost, sometimes called opportunity cost, were calculated using a modular method which is based on risk allowances, e.g. the risk of company size, liquidity, indebtedness or profitability. Market methods of determining own cost of capital, which are often presented in technical literature, could not be applied due to the unavailability of information on the beta coefficient. Beta expresses the degree a specific market risk by means of measuring the sensitivity of a stock to changes in a market portfolio [7, p. 324]. Another aim of this article was to verify the dependency of the Altman Z-score and of the weighted average cost of capital.

## **3 Methods**

During the compilation of this article data contained in the administrative registers of the economic entities were used. [12]

Companies that actively carry out business activities and whose business activities are classified as OKEČ 790000; i.e. travel agencies whose legal form is that of a joint-stock company were selected to create a primary group consisting of 374 statistical units. Subsequent systematic selection (of every sixth company) generated a selection set that contained the business identification numbers of the selected companies.

Then, data presented in final accounts published in the Commercial Register were processed. [13] The data used were the data required for the calculation of the Altman Z-score, which works as a financial analysis instrument, and of the weighted average cost of capital (WACC) from the years before and after the crisis period of 2007-2010.

When processed, these data created a file to be evaluated. Regression analysis and correlation analysis were used to investigate the dependencies defined in the hypotheses. Regression analysis monitored dependency using the method of least squares and the index of determination. The correlation coefficient from correlation analysis was used as a test of the size and direction of the dependency. Spearman coefficient was used too.

Furthermore, a non-parametric signed-rank test was performed to identify the impact of the economic crisis on the financial health of a company and on WACC.

## **4 Problem solving**

### **4.1 Financial analysis based on Altman Z-score**

Accounting data covering the years 2007-2010 were adopted from final accounts. Balance sheets provided the following data: current assets, equity, borrowed capital, total capital, retained earnings from previous years, short-term liabilities, long-term

and short-term credits and other long-term liabilities, profit after tax, e.g. liability towards a controlling person. Profit and loss statements provided the following data: revenues, interest paid and profit before tax. Because as many as 70% of selected companies fail to meet their statutory duty to publish final accounts in the Commercial Register only 17 companies' data could be used for calculation; i.e. only 30% of the original selected group had at their disposal complete data regarding the years in concern.

The available data were used to calculate Altman Z-score for every company and every single year (Tab. 2). Altman index of financial health referred to as the Z-score model, or Altman Z-score uses discriminant analysis to draw a line between companies that are highly likely to go into bankruptcy and companies that are not jeopardized by bankruptcy. Altman's model was designed on the basis of data provided by both successful manufacturers and manufacturer who subsequently went into bankruptcy. As a result he created a model based on five ratio indicators and their relevant weights:

$$z = \sum_{i=1}^5 w_i x_i \quad (1)$$

**Tab. 1: Altman Z-score applicable to unquoted companies**

Parameter	Weight	Indicator
X <sub>1</sub>	0,717	Net working capital /assets
X <sub>2</sub>	0,847	Accumulated profit /assets
X <sub>3</sub>	3,107	EBIT/assets
X <sub>4</sub>	0,420	Equity /borrowed capital
X <sub>5</sub>	0,998	Revenues /assets
z	z>2.7 financially stable company z<1.2 companies at risk of bankruptcy	

*Source: [own data processing]*

Table 1 implies that the higher the z-score, the better a company's performance. The global economic crisis that affected companies in the Czech Republic as well and thus could have had negative impact on this indicator. Therefore, it was appropriate to examine this index in the year 2007; i.e. prior to the beginning of the world crisis and to compare it with the same index during and after the crisis. This is why the following hypothesis was formulated:

**H1<sub>0</sub>: Before the world crisis (in 2007) and during the crisis (in 2009) the financial health of the monitored companies showed the same tendencies.**

**H2<sub>0</sub>: Before the world crisis (in 2007) and after the crisis (in 2010) the financial health of the monitored companies showed the same tendencies.**

The hypothesis was subjected to a matched-pairs signed-rank test. The test was chosen in view of the fact that the standard division of the basic group could not be



considered. The random quantities  $D_i = X_i - Z_i$ ,  $i = 1, 2, \dots, 17$  (i.e.  $n = 17$ ) was introduced and the tested hypothesis was defined as follows:

$$H_0: X_D = 0 \text{ versus this hypothesis: } H_1: X_D \neq 0$$

Were  $X_D$  is the median of the random quantity  $D_i$ . The calculation of the random quantity is shown in Tab. 2.

**Tab. 2: Altman Z-score of the financial health of the monitored companies in the years 2007-2010**

Altman Z-score of financial health				$D_i = X_i - Z_i$	
2007 = $Z_i$	2008	2009 = $X_i$	2010 = $X_i$	2010&2007	2009&2007
0.31	0.87	0.65	0.71	0.4	0.34
0.5	0.93	0.21	0.98	0.48	-0.29
0.64	8.34	4.57	1.95	1.31	3.93
0.86	5.99	3.62	6.66	5.8	2.76
0.89	4.56	3.77	1.47	0.58	2.88
1.09	0.74	0.88	1.15	0.06	-0.21
1.14	1.59	3.19	2.76	1.62	2.05
1.47	1.85	1.83	2.38	0.91	0.36
1.58	1.5	1.45	1.88	0.3	-0.13
1.85	2.9	3.29	2.59	0.74	1.44
2.03	2.04	1.32	2.56	0.53	-0.71
2.28	1.56	1.73	2.44	0.16	-0.55
2.34	3.59	4.11	2.81	0.47	1.77
2.35	2.6	2.37	3.07	0.72	0.02
2.87	2.54	2.92	2.56	-0.31	0.05
3.28	3.87	1.72	1.25	-2.03	-1.56
7.18	6.8	4.5	3.2	-3.98	-2.68
Y				14	10

Source: [own data processing]

The number of differences with plus signs is expressed by the random quantity  $Y$  for which it holds that the critical area is a set of the values of the random quantity  $Y$ :  $W = \{Y; Y \leq k_1 \text{ and simultaneously } Y \geq k_2\}$ , whereas it holds for  $n = 17$  that  $k_1 = 4$ ,  $k_2 = 13$ . [8, p. 22]

The hypothesis  $H_{10}$  (“ $H_{10}$ : Before and during the crisis the financial health of the monitored companies showed the same tendency.”) is not rejected because the value of the testing criterion fell into the area of admissible values.

The hypothesis  $H_{2_0}$  (“ $H_{2_0}$ : Before and after the crisis the financial health of the monitored companies showed the same tendency.”) is rejected because the value of the testing criterion fell into the area of critical values.

### **3.2 The effects of the economic crisis on the weighted average cost of capital (WACC)**

The weighted average cost of capital indicates how expensive a source of funding is used by a company. In the time of crisis companies might tend to contract debts as they might lack in equity. Subsequently, WACC would be reduced because borrowed capital is generally cheaper than equity. It is in this connection that the two following hypotheses are made:

**H<sub>3\_0</sub>: Before the crisis (in 2007) and during the crisis (in 2009) the companies had the same cost of capital.**

**H<sub>4\_0</sub>: Before the crisis (in 2007) and after the crisis (in 2010) the companies had the same cost of capital.**

The statistical analysis of hypotheses testing was based on the following calculation of weighted cost of capital (WACC):

$$WACC = R_D \times (1 - t) \times D/C + R_E \times E/C \quad (2)$$

Where:

WACC is the weighted average cost of capital,

$R_D$  is the cost of borrowed capital,  $t$  is a corporate income tax rate,  $D$  is borrowed capital,  $C$  is total capital,  $R_E$  is the cost of equity,  $E$  is equity.

The interest paid reported in the profit and loss statements of the companies in concern was substituted for the cost of borrowed capital.

While the determination of the cost of borrowed capital is simple and straightforward, the cost of capital can be calculated by means of several methods that differ as to the requirements for input information:

In general, the cost of equity can be determined on the basis of market approaches or by means of methods and models based on accounting data. The primary methods used to estimate the cost of equity are: [2, p. 110]

- Capital Asset Pricing Model (CAPM),
- Arbitrage Pricing Model (APM),
- Dividend Growth Model, and
- Modular Models.

The market models CAPM and APM require the knowledge of the beta coefficient. If a company does not pay for a rating evaluation, it has practically no other way to express this coefficient in a more precise way. The dividend model is more suitable for the needs of future investors. Therefore, the modular data based on available accounting data proves appropriate for the appraisal of one's own cost of capital for the purpose of making decision regarding financial sources.

The modular model comes from the sum of individual risk premiums and of the rate of return of a risk-free asset. This relation can be simply described as follows:

$$WACC_U = R_F + R_{podnikatelské} + R_{finstab} + R_{LA} [2, p. 112] \quad (3)$$

Where:  $WACC_U$  is the cost of total capital of a debt-free company,  $R_F$  is the risk-free rate of interest,  $R_{podnikatelské}$  is a risk premium for business risk,  $R_{finstab}$  is risk premium for risk ensuing from financial stability,  $R_{LA}$  is a risk premium that characterizes the size of a company.

The author of this article followed the methodology based on the modular model that is used by the Czech Ministry of Industry and Trade. [7, p. 325] In principle, this methodology describes the calculation (3) and provides clear instructions on what data from accounting statements are to be used. The results are presented in Tab. 3.

**Tab. 3: Weighted average cost of capital (WACC) of the monitored companies in the years 2007-2010**

Weighted average cost of capital (WACC)				$D_i = X_i - Z_i$	
2007 = $Z_i$	2008	2009 = $X_i$	2010 = $X_i$	2010&2007	2009&2007
0.093	0.126	0.044	0.088	-0.005	-0.049
0.071	0.095	0.078	0.013	-0.058	0.007
0.011	0.006	0.090	0.050	0.039	0.079
0.089	0.095	0.039	0.072	-0.017	-0.050
0.268	0.101	0.148	0.227	-0.041	-0.120
0.076	0.045	0.089	0.047	-0.029	0.013
0.043	0.177	0.086	0.113	0.070	0.042
0.100	0.165	0.114	0.131	0.031	0.014
0.186	0.051	0.038	0.105	-0.081	-0.148
0.085	0.057	0.114	0.018	-0.067	0.029
0.141	0.136	0.047	0.202	0.061	-0.093
0.079	0.112	0.096	0.134	0.054	0.017
0.074	0.075	0.446	0.125	0.051	0.372
0.036	0.027	0.256	0.041	0.005	0.220
0.071	0.832	0.056	0.045	-0.026	-0.015
0.062	0.150	0.118	0.025	-0.038	0.055
0.107	0.041	0.021	0.061	-0.046	-0.086
Y				7	10

Source: [own data processing]

The hypothesis was subjected to a matched-pairs signed-rank test. The random quantity  $D_i = X_i - Z_i$ ,  $i = 1, 2, \dots, 17$  (i.e.  $n = 17$ ) was introduced and the tested hypothesis was defined as follows:

$$H_0: X_D = 0 \text{ versus this hypothesis: } H_1: X_D \neq 0$$

The number of differences with plus signs is expressed by the random quantity  $Y$  for which it holds that the critical area is a set of the values of the random quantity  $Y$ :  $Y: W = \{Y; Y \leq k_1 \text{ and simultaneously } Y \geq k_2\}$ , whereas it holds for  $n = 17$  that  $k_1 = 4$ ,  $k_2 = 13$  [8, p.22].

The hypothesis  $H_{30}$  (“Before and during the crisis the companies had the same cost of capital.”) is not rejected because the value of the testing criterion fell into the area of admissible values.

The hypothesis  $H_{40}$  (“Before and after the crisis the companies had the same cost of capital.”) is not rejected because the value of the testing criterion fell into the area of critical values.

### 3.3 The effect of financial health on WACC

The primary task of every financial manager is [5, p.110]:

- a) To secure economically justified budgeted capital for investments forecasted by the company that meet the required rate of return,
- b) To achieve the least possible cost of required investments,
- c) Not to disturb financial stability (not to substantially increase the company’s financial risk) – e.g. by disproportionate use of long-term borrowed capital for the financing of investments.

The above information implies that strategic financing should ensure the required amount of capital provided that the cost of financing sources are kept at a minimum and that the company retains its financial stability (financial health). However, is it possible to fully meet both these criteria; i.e. the minimum cost of capital and the maximum index of financial health? Is there any dependency between these quantities? These questions are addressed by the following hypothesis:

**$H_{50}$ : There is no dependency between financial health and the weighted average cost of capital.**

The hypothesis that there is no correlation relation between the random quantities  $X_i$  and  $Y_i$  (a company’s financial health expressed in terms of Altman Z-score and the cost of capital or WACC) was tested. The tested hypothesis is defined as follows:

$$H_0: \rho = 0 \text{ versus this hypothesis: } H_1: \rho \neq 0$$

This problem will first be solved using Spearman correlation coefficient. The results of Spearman test will be verified by regression analysis and correlation coefficient.

Spearman correlation coefficient was chosen because the assumption of the normality of the division of basic group probability was not met. [Kubanova p. 157] the testing criterion is defined as follows: [9, p.157]

$$R_S = 1 - \frac{6}{n \cdot (n^2 - 1)} \sum_{i=1}^n (R_i - Q_i)^2 \quad (4)$$

Where:  $n$  is the number of elements to choose from,  $R_i$  is the sequence of the  $i$ th element of the random quantity  $X_i$  in non-descending order,  $Q_i$  is the sequence of the  $i$ th element of the random quantity  $Y_i$  in non-descending order.

The critical area is defined as a set of the values of the testing criterion  $R_S$  for which the following holds:  $W = \{ R_S : |R_S| > r_{0.05} \}$ , whereas  $r_{0.05}$  where  $n = 17$  is 0.4853. [8, p. 22]

The results presented in Tab. 4 clearly show that the value of the testing criterion never fell into the critical area; i.e. the hypothesis  $H_{50}$  is not rejected; and the random quantities of a company's financial health and the cost of capital are independent of each other.

Tab. 4 also features the results of the determination index and the correlation coefficient.

The correlation coefficient [9, p. 144] assumes small values, which is evidence of the non-correlativity of both random quantities. If the values were approaching 1, it would indicate dependence.

The last indicator used to examine the independence between Altman Z-score and the cost of capital is the determination index. This index represents regression analysis.

The determination index expresses the ratio of the explained part of dispersion to total dispersion. It is calculated as follows:

$$R^2 = \frac{S_t}{S_y} \quad (6)$$

Where:  $S_t$  is the part of variability that can be explained by means of a regression model (specifically, by a line),  $S_y$  is the sum of squared deviations.

The determination index defines what part of the variability of monitored values can be explained by means of the given model. It assumes values  $\langle 0,1 \rangle$ . The smaller the unexplained part of dispersion, the better the ability of the given function to express dependency and the determination index approaches 1.

The data presented in Tab. 4 suggest that the determination index confirmed the absence of any dependency between Altman Z-score and WACC.

**Tab. 4: Indicators of the dependence of Altman Z-score and of the cost of capital in the years 2007-2010**

Indicators	2007	2008	2009	2010
Spearman coefficient	-0.0539	0.0564	0.1789	-0.0784
Determination index	0.0003	0.0789	0.0651	0.0067
Correlation coefficient	-0.0270	0.3046	0.2573	-0.1009

Source: [own data processing]

The graphs in figures No. 1 and 2 provide the final representation of proven independence. The interlaid line does not characterize real values. Deviations from the trend are too large.

**Fig. 1: The dependence of Altman Z-score and WACC in 2007**

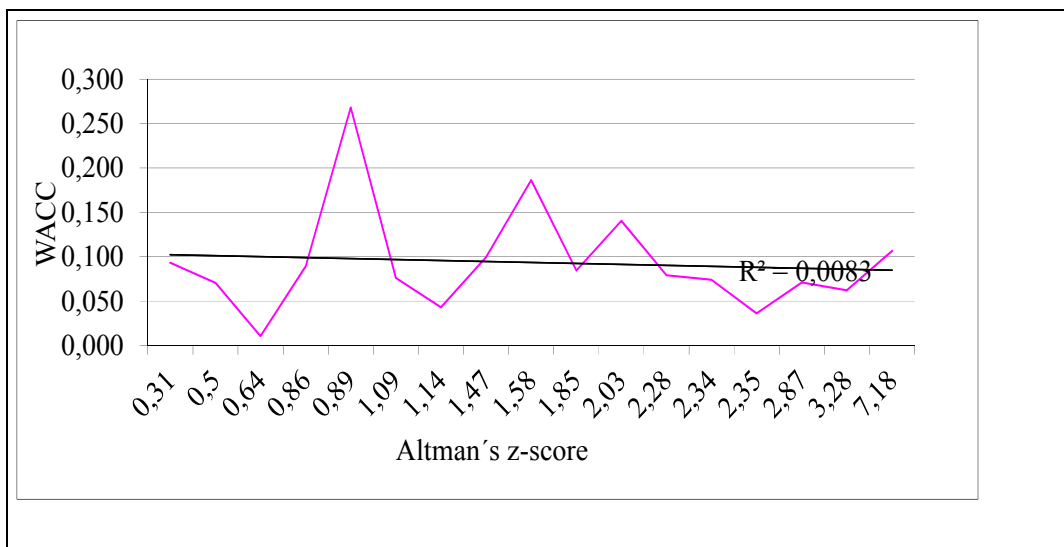

Source: [own data processing]

**Fig. 2: The dependence of Altman Z-score and WACC in 2010**

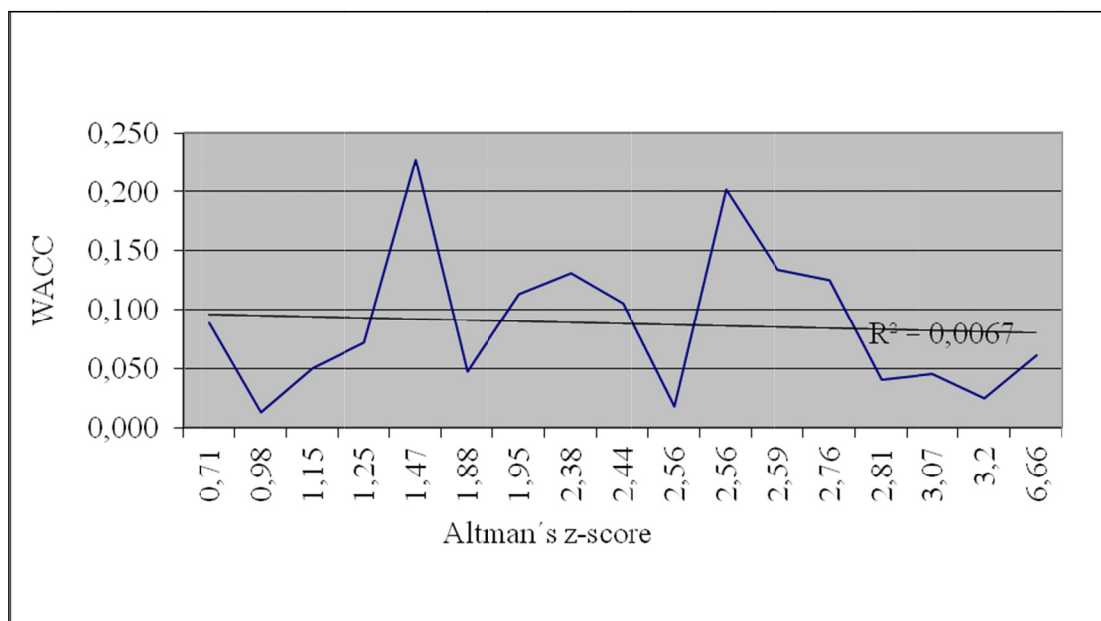

Source: [own data processing]

## 5 Discussion

The aim of this article was to assess the degree to which monitored companies were affected by the economic crisis that started in 2008. The indicator used to measure this impact was the Altman index of financial health whose calculation was based on the data presented included in the final accounts of the companies included in the study. The tests of statistical hypotheses showed that the companies were not affected by a lower Z-score during the crisis. Interesting results were revealed by an after-crisis test that identified even higher z-scores after the crisis than before the crisis; i.e. the companies became more financially sound.

Furthermore, this article also dealt with the average cost of capital, or WACC, and with the effects of the financial crisis on WACC. The study did not prove any impact of the crisis on WACC.

### Hypotheses recapitulation:

Before the world crisis (in 2007) and during the crisis (in 2009) the financial health of the monitored companies showed the same tendencies.

H<sub>20</sub>: Before the world crisis (in 2007) and after the crisis (in 2010) the financial health of the monitored companies did not show the same tendencies.

H<sub>30</sub>: Before the crisis (in 2007) and during the crisis (in 2009) the companies had the same cost of capital.

H<sub>40</sub>: Before the crisis (in 2007) and after the crisis (in 2010) the companies had the same cost of capital.

H<sub>50</sub>: There is no dependence between financial health and the weighted cost of capital.

**Tab. 5: Results of hypothesis testing**

Hypothesis	Testing results
H1 <sub>0</sub>	Not rejected.
H2 <sub>0</sub>	Rejected.
H3 <sub>0</sub>	Not rejected.
H4 <sub>0</sub>	Not rejected.
H5 <sub>0</sub>	Not rejected.

*Source: [own data processing]*

The final part of the article paid attention to the possible dependence between a company's financial health and the weighted average cost of capital. Both correlation and regression analysis revealed the non-existence of dependence between financial health and the weighted average cost of capital.

## **Conclusion**

This article was compiled in order to assess the impact of the financial crisis on companies operating in the field of travel agencies. This field already faces financial problems that are likely to be further aggravated by the crisis.

The initial data used in this study were obtained from financial reports of 2007. A summarized financial indicator was computed from those data and then compared with the value of the same indicator applicable to a year falling within the crisis (2009) and to a year after the crisis (2010).

It was confirmed that the crisis did not contribute to the worsening of the companies' financial standing during the crisis. On the contrary, financial results achieved after the crisis were even better than before the crisis.

The same principle was applied to the examination of the weighted average cost of capital that was also expected to change due to the crisis. However, no impact of the crisis was proven.

Considering that the index of financial health and the weighted average cost of capital belong to the most significant financial indicators it is necessary to monitor the relations between the two. The question presents itself whether there is any type of dependence between them; i.e. whether the optimization of either of them affects the other, and if it does, what is the nature of dependence. However, the companies under review did not show any type of dependence.

The original aim of this study was to examine the complete group of the selected companies. However, because a number of the companies did not have their complete final accounts of the period 2007-2010 published on publicly accessible servers the selected group had to be markedly reduced. For instance, it did not include small companies (established after 2008) or companies whose operation was terminated prior to 2010, perhaps due to the aftermath of the crisis.



The calculations presented in this article should offer a more optimistic view of the financial crisis. The generally negative understanding of the impacts of the crisis – which is often even further intensified by the media – cannot be held as dogma. It is always necessary to assess a specific field, a concrete group of companies or a specific company, while simultaneously defining indicators to be researched. Not all results established by this study were as bad as they might have appeared.

Another, no less important aim was to evaluate two significant quantities used in financial management, namely Altman Z-score (that represents the most relevant aspects of financial analysis) and the weighted average cost of capital. It was necessary to prove whether and to what degree these qualities are correlated, because this information could be valuable for financial managers who attempt to secure the best financing possible as well as financial stability. However, our investigation proved that these two indicators are independent. This means that financial managers have to consider each quantity separately.

### Acknowledgement

This contribution was supported by GA ČR No. SGFES03/2012.

### References

- [1] BREALEY, Richard A. Teorie a praxe firemních financí. Vyd. 1. Praha: Computer Press, 2000, 1064 s. ISBN 80-722-6189-4.
- [2] DLUHOŠOVÁ, Dana. Finanční řízení a rozhodování podniku: analýza, investování, oceňování, riziko, flexibilita. Vyd. 1. Praha: Ekopress, 2006, s. 104-114. ISBN 80-86119-58-0.
- [3] DUCHOŇ, Bedřich. Inženýrská ekonomika. Vyd. 1. Praha: C. H. Beck, 2007, s. 169-185. ISBN 978-80-7179-763-0.
- [4] Fundamentals of financial management. 10th ed. Cincinnati, Ohio: South-Western, 2004. ISBN 03-242-0306-3.
- [5] HRDÝ, Milan. Strategické finanční řízení a investiční rozhodování: učebnice pro kombinované a distanční studium, Fakulta ekonomická, Západočeská univerzita Plzeň. 1. vyd. Praha: Bilance, 2008, 199 s. ISBN 978-80-86371-50-4 (Brož.).
- [6] JINDŘICHOVSKÁ, Irena. Podnikové finance. Vyd. 1. Praha: Management Press, 2001, 316 s. ISBN 80-726-1025-2.
- [7] KISLINGEROVÁ, Eva. Manažerské finance. 1. vyd. Praha: C. H. Beck, 2004, 714 s. ISBN 80-717-9802-9.
- [8] KUBANOVÁ, Jana a Bohdan LINDA. Kritické hodnoty a kvantily vybraných rozdělání pravděpodobností. Vyd. 1. Pardubice, 2006, 53 s. ISBN 80-719-4852-7.
- [9] KUBANOVÁ, Jana. Statistické metody pro ekonomickou a technickou praxi. 2. Bratislava: Statis, 2004. ISBN 80-85659-37-9.
- [10] MELICHER, Ronald W, Edgar NORTON a Laura TOWN. Finance. Hoboken, NJ: Wiley, c2007, 572 s. ISBN 978-047-0007-204.

- [11] Meritum : Účetní závěrka 2007. Praha : Aspi, a. s., 2007. 506 s. Dostupný z WWW: <aspimeritum.cz>.
- [12] MINISTERSTVO FINANCÍ ČR. ARES: Administrativní registr ekonomických subjektů [online]. 2012 [cit. 2012-02-25]. Dostupné z: <http://www.info.mfcr.cz/ares>
- [13] MINISTERSTVO SPRAVEDLNOSTI. Justice.cz: Oficiální server českého soudnictví [online]. 2012 [cit. 2012-03-14]. Dostupné z: <http://portal.justice.cz/justice2/uvod/uvod.aspx>
- [14] SYNEK, Miloslav. Manažerská ekonomika. 3. přeprac. a aktualiz. vyd. Praha: Grada, c2003, 466 s. ISBN 80-247-0515-X.
- [15] SYNEK, Miloslav. Podniková ekonomika. 3. přeprac. a dopl. vyd. Praha: C. H. Beck, 2002, 479 s. Beckovy ekonomické učebnice. ISBN 80-717-9736-7.
- [16] VALACH, Josef. Finanční řízení podniku. 2. aktualiz. a rozš. vyd. Praha: Ekopress, 1999, 324 s. ISBN 80-861-1921-1.
- [17] WÖHE, Günter. Úvod do podnikového hospodářství. 2. přeprac. a dopl. vyd. Praha: C. H. Beck, 2007, 928 s. Beckovy ekonomické učebnice. ISBN 978-807-1798-972.

### **Contact Address**

#### **Ing. Irena Honková**

Univerzita Pardubice, Fakulta ekonomicko-správní  
Studentská 84, 532 10 Pardubice, Česká republika  
Email: irena.honkova@student.upce.cz  
Tel.: +420 466 036 664

Received: 27. 04. 2012

Reviewed: 01. 06. 2012

Approved for publication: 01. 11. 2012

# USING CLUSTER ANALYSIS FOR THE STUDY OF GENERATION Y BEHAVIOR AT THE UNIVERSITY OF PARDUBICE

**Hana Jonášová, Karel Michálek, Jan Panuš**

**Abstract:** *For Generation Y are social networks an essential element of communication and entertainment. The authors of this article conducted research in the Faculty of Economics and Administration at the University of Pardubice on how students (generation Y) use social networks. For the evaluation of research were used cluster analysis and decision trees.*

**Keywords:** *Generation Y, Social network, Faculty of Economics and Administration University of Pardubice, Facebook, Communication, Questionnaire survey, Cluster analysis, Kohonen self-organizing feature maps, K-Means, Two-Step, C5.0, Decision trees.*

**JEL Classification:** *C15, C44, C63, Y10.*

## Introduction

Generation Y [2], [5], [10] is shaped by the period in which they live. The generation grows up surrounded by modern technology that is, of course, completely used from an early age. The global expansion of the Internet and mobile networks was very important for the formation of this generation.

We were interested in the specifics Generation Y of the Faculty of Economics and Administration, University of Pardubice. Therefore we made a questionnaire survey to clarify how this generation communicates with each other and how uses the means social networks. We focused mainly on selected internet social networks in this study. The contribution of this article is within describing of this generation and the network by statistical methods and methods of cluster analysis.

## 1 Problem formulation

This paper builds on an article [4] that focused on the preparation of questionnaires for this research and primary processing. We discussed the status of social networks and their influence on Generation Y in the University of Pardubice in this article. This article raised many more questions for us. How to describe the structure of social networks? What is the relationship between the social networks? Who are the typical users at the University of Pardubice?

We made two rounds of questionnaire survey as described in the [4]. We asked respondents how often they use social networks for their communication and how much time they spend with the computer in the first round. Respondents were asked to describe their own social network in the second round. We asked 182 respondents from Faculty of Economics and Administration, University of Pardubice.

Questions were classified to two subscales a) importance of the internet, b) using web services as communication or for leisure activities.

## **2 Problem solving**

The questionnaire process, primary data pre-processing and rough summary was published in [4]. We decided for additional data processing to use cluster analysis. This enables evaluating and understanding data obtained from the survey. The method for understanding the various clusters was decision trees. The combination of these methods is often used. Using the combination of these techniques in relation to social networks is described in [1].

### **2.1 Data preprocessing**

Data must be transformed from the individual questionnaires to a CSV file for processing in software Clementine 10.1. These data were adjusted manually and then using the scaling function of MS Excel covered in the appropriate form.

The next step for data preprocessing and analysis was necessary to treat some of the characteristics. These were mainly about Internet services, which were represented in the questionnaire with near zero frequency.

We removed the following services: Lidé.cz; Libímseti.cz; LinkedIn; Twitter; Orkut; Flickr; MySpace; N-JOY.cz; Vimeo; Picasa; Rajče.net; Facebook games.

#### **Cluster Analysis**

Therefore, to understand semantics data obtained from the research of the Kohonen networks were used in order to determine the number of primary clusters. Cluster analysis was performed in software Clementine 10.1. It was based on data text file (CSV) which was processed in MS Excel. We used Two-Step algorithm and K-Means method for additional processing.

### **2.2 Kohonen self-organizing feature maps**

Kohonen self-organizing feature maps [6] are a type of neural network based on competitive learning strategy, the input layer serves the distribution of the input patterns. The neurons in the competitive layer (output layer) serve as representatives, and they are organized into topological structure. All the input neurons are connected to all of the output neurons, and between these connections are weights, associated with them and there is distances computed between them. The winning neuron is chosen, for which the distance from input pattern is minimum.

This type of network can be used for clustering data sets into distinct groups when unsupervised method is used. Records are grouped so that records within a group or cluster tend to be similar to each other, and records in different groups are dissimilar.

The result of cluster analysis using Kohonen maps is given in Fig. 1, it describes the different clusters and the various input variables for different clusters (Facebook, ICQ, Skype, Spolužáci.cz, You Tube, time spent at the computer, college dormitory, year of birth, field of study).

**Fig. 1: The result of cluster analysis using Kohonen maps**

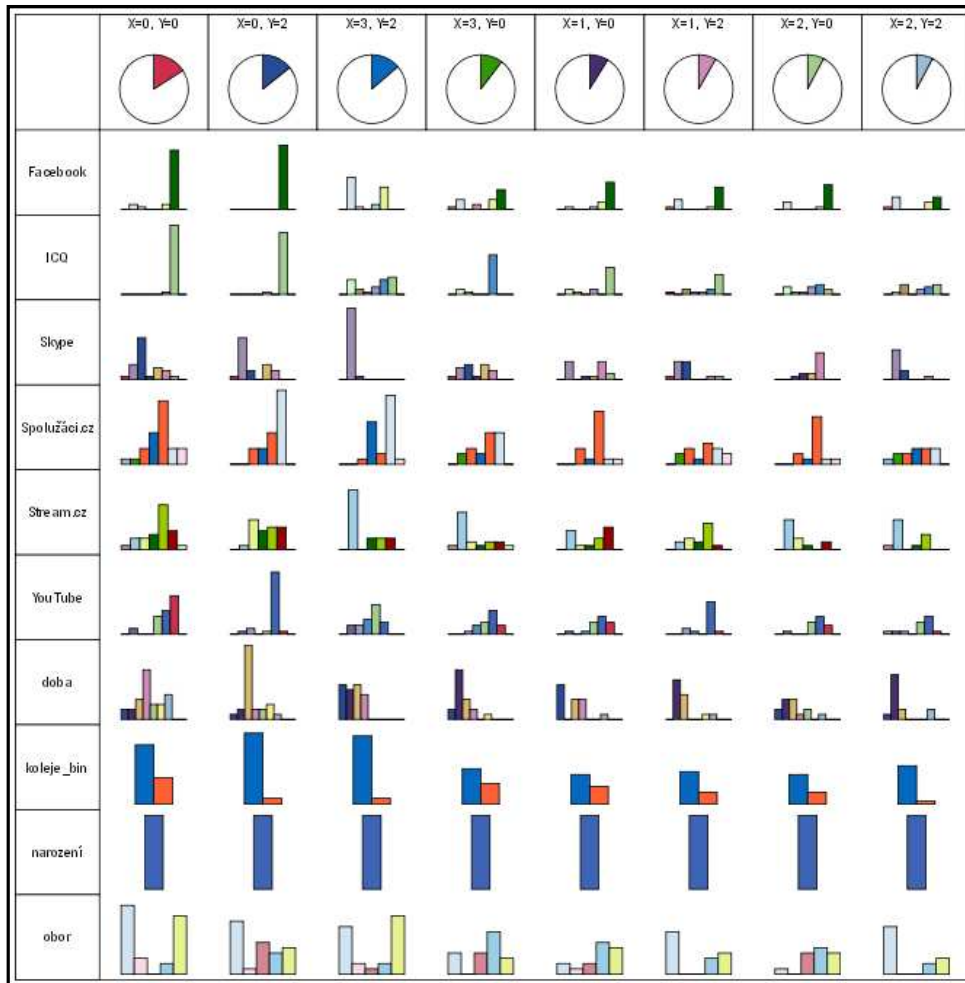

Source: own

Numbers of elements in clusters, created by Kohonen maps are given in Tab. 1. Cluster analysis using Kohonen maps created 12 clusters. But the total numbers of 12 clusters are only 3 clusters significant (highlighted cells). The number of clusters will be further used for other clustering methods.

**Tab. 1: Number of clusters**

Y, X	0	1	2	3
0	29	16	14	19
1	5	4	6	9
2	26	14	14	25

Source: own

### 2.3 Two-Step Algorithm

Two-Step Cluster is a two-way clustering method. The first step makes a single pass through the data, during which it compresses the raw input data into a manageable set of sub clusters. The second step uses a hierarchical clustering method to progressively merge the sub clusters into larger and larger clusters, without

requiring another pass through the data. Hierarchical clustering has the advantage of not requiring the number of clusters to be selected ahead of time. Many hierarchical clustering methods start with individual records as starting clusters and merge them recursively to produce ever larger clusters. Though such approaches often break down with large amounts of data, Two-step's initial pre-clustering makes hierarchical clustering fast even for large data sets.

Two-Step clustering method could be used, since using Kohonen map was the chosen number of clusters. For easier interpretation of cluster analysis 3 target clusters was selected. The results of cluster analysis are the following tables. The tables (Tab. 2 – 7) show percentage of respondents belonging to the cluster, and what value is dominant. The rows of table are scale, how often is the social network used. Highlighted cells are dominant for the cluster. The tables (Tab. 8 – 10) show the results from another perspective. Individual monitored variables are in the rows. Highlighted cells are dominant for the cluster.

**Tab. 2: Results for Facebook**

Facebook	cluster 1	cluster 2	cluster 3
0	2,35%	0,00%	3,7%
1	30,59%	2,86%	29,63%
2	2,35%	1,43%	0,00%
3	1,18%	1,43%	0,00%
4	4,71%	0,00%	0,00%
5	25,88%	8,57%	3,7%
6	32,94%	85,71%	62,96%

Source: own

**Tab. 3: Results for ICQ**

ICQ	cluster 1	cluster 2	cluster 3
0	1,18%	0,00%	0,00%
1	16,47%	0,00%	7,41%
2	12,94%	0,00%	3,70%
3	4,71%	2,86%	0,00%
4	10,59%	5,71%	0,00%
5	32,94%	8,57%	18,52%
6	21,18%	82,86%	70,37%

Source: own

**Tab. 4: Results for Skype**

Skype	cluster 1	cluster 2	cluster 3
0	3,53%	1,43%	3,7%
1	56,47%	20,00%	66,67%
2	12,94%	27,14%	25,93%
3	3,53%	2,86%	0,00%
4	4,71%	21,43%	0,00%
5	17,65%	21,43%	3,70%
6	1,18%	5,71%	0,00%

Source: own

**Tab. 5: Results for Spolužáci.cz**

Spolužáci	cluster 1	cluster 2	cluster 3
0	2,35%	2,86%	0,00%
1	7,06%	1,43%	3,70%
2	18,82%	11,43%	3,70%
3	18,82%	18,57%	0,00%
4	32,94%	42,86%	0,00%
5	20,00%	15,71%	81,48%
6	0,00%	7,14%	11,11%

Source: own

**Tab. 6: Results for Stream.cz.**

Stream.cz	cluster 1	cluster 2	cluster 3
0	2,35%	1,43%	0,00%
1	58,82%	14,29%	7,41%
2	5,88%	17,14%	22,22%
3	9,41%	7,14%	33,33%
4	20%	31,43%	3,70%
5	3,53%	25,71%	25,93%
6	0,00%	2,86%	7,41%

Source: own

**Tab. 7: Results for YouTube.cz..**

YouTube	cluster 1	cluster 2	cluster 3
0	1,18%	0,00%	0,00%
1	1,18%	5,71%	0,00%
2	8,24%	1,43%	11,11%
3	12,94%	0,00%	7,41%
4	30,59%	17,14%	0,00%
5	30,59%	40,00%	81,48%
6	7,06%	35,71%	0,00%

Source: own

**Tab. 8: Sex of the respondent of cluster analysis.**

Sex	cluster 1	cluster 2	cluster 3
men	25,88%	28,57%	3,70%
woman	74,12%	71,43%	96,3%

Source: own

**Tab. 9: Grade of cluster analysis.**

Grade	cluster 1	cluster 2	cluster 3
1	0%	2,86%	3,70%
2	96,47%	87,14%	88,89%
3	3,53%	10%	7,41%

Source: own

**Tab. 10: Time spent at the computer of cluster analysis.**

Time	cluster 1	cluster 2	cluster 3
1	22,35%	11,43%	0,00%
2	41,18%	10,00%	22,22%
3	18,82%	24,29%	59,26%
4	10,59%	25,71%	0,00%
5	1,18%	10,00%	3,7%
6	1,18%	8,57%	11,11%
7	4,71%	10,00%	3,70%

Source: own

## 2.4 K-Means method

K-Means [7] defines a set of starting cluster centres derived from data. It then assigns each record to the cluster to which it is most similar, based on the record's input field values. After all cases have been assigned, the cluster centres are updated to reflect the new set of records assigned to each cluster. The records are checked again to see whether they should be reassigned to a different cluster, and the record assignment/cluster iteration process continues until either the maximum number of iterations is reached, or the change between one iteration and the next fails to exceed a specified threshold. The tables (Tab. 11 - 16) show the percentage of respondents belonging to the cluster, and what value is dominant. The rows of table are scale; it shows how often the social network is used. Highlighted cells are dominant for the

cluster. The tables (Tab. 17 – 19) show the results from another perspective. Individual monitored variables are in the rows. Highlighted cells are dominant for the cluster.

**Tab. 11: Results for Facebook.**

Facebook	cluster 1	cluster 2	cluster 3
0	0,00%	2,17%	4,76%
1	10,64%	34,78%	23,81%
2	2,13%	0,00%	2,38%
3	1,06%	0,00%	2,38%
4	2,13%	0,00%	4,76%
5	20,21%	10,87%	11,90%
6	63,83%	52,17%	50,00%

Source: own

**Tab. 12: Results for ICQ.**

ICQ	cluster 1	cluster 2	cluster 3
0	1,06%	0,00%	0,00%
1	11,70%	2,17%	9,52%
2	8,51%	0,00%	9,52%
3	5,32%	0,00%	2,38%
4	8,51%	2,17%	9,52%
5	28,72%	6,52%	21,43%
6	36,17%	89,13%	47,62%

Source: own

**Tab. 13: Results for Skype.**

Skype	cluster 1	cluster 2	cluster 3
0	3,19%	2,17%	2,38%
1	38,30%	56,52%	42,86%
2	21,28%	21,74%	16,67%
3	5,32%	0,00%	0,00%
4	10,64%	6,52%	14,29%
5	20,21%	8,70%	19,05%
6	1,06%	4,35%	4,76%

Source: own

**Tab. 14: Results for Spolužáci.cz.**

Spolužáci	cluster 1	cluster 2	cluster 3
0	1,06%	2,17%	4,76%
1	3,19%	2,17%	4,76%
2	11,70%	17,39%	14,29%
3	17,02%	4,35%	26,19%
4	44,68%	2,17%	35,71%
5	17,02%	65,22%	9,52%
6	5,32%	6,52%	0,00%

Source: own

**Tab. 15: Results for Stream.cz.**

Stream.cz	cluster 1	cluster 2	cluster 3
0	0,00%	0,00%	7,14%
1	39,36%	30,43%	26,19%
2	8,51%	15,22%	19,05%
3	7,45%	17,39%	16,67%
4	27,66%	8,7%	23,81%
5	15,96%	23,91%	4,76%
6	1,06%	4,35%	2,38%

Source: own

**Tab. 16: Results for YouTube.cz.**

YouTube	cluster 1	cluster 2	cluster 3
0	0,00%	0,00%	2,38%
1	7,45%	2,17%	9,52%
2	7,45%	6,52%	9,52%
3	13,83%	0,00%	2,38%
4	27,66%	10,87%	0,00%
5	25,53%	76,09%	40,48%
6	18,09%	4,35%	28,57%

Source: own

**Tab. 17: Sex of the respondent of cluster analysis.**

Sex	cluster 1	cluster 2	cluster 3
men	0,00%	2,17%	100%
woman	100,00%	97,83%	0%

Source: own

**Tab. 18: Grade of cluster analysis**

Grade	cluster 1	cluster 2	cluster 3
1	1,06%	2,17%	2,38%
2	94,68%	86,96%	90,48%
3	4,26%	10,87%	7,14%

Source: own



**Tab. 19: Time spent at the computer of cluster analysis.**

Time	cluster 1	cluster 2	cluster 3
1	22,34%	2,17%	11,9%
2	35,11%	6,52%	28,57%
3	20,21%	45,65%	21,43%
4	9,57%	26,09%	21,43%
5	0,00%	10,87%	9,52%
6	6,38%	6,52%	9,52%
7	6,38%	2,17%	9,52%

*Source: own*

The results of cluster analysis using K-means algorithm is little apparent differentiation between clusters. Maximum numbers of items (highlighted in the table cells) are almost identical in all properties. Therefore, for further work the results have been chosen from cluster analysis using Two-Step algorithm.

## 2.5 Evaluation of cluster analysis

To analyze the results of cluster analysis we chose decision trees. We tested three models of decision trees: C 5.0, Classification and Regression (C&R) Tree and QUEST.

Decision tree models allow developing classification systems that predict or classify future observations based on a set of decision rules. If we have data divided into classes that interest us, we can use our data to build rules that we can use to classify old or new cases with maximum accuracy.

A C5.0 [8], [9] model works by splitting the sample based on the field that provides the maximum information gain. For each subsample defined by the first split is then split again, usually based on a different field, and the process repeats until the subsamples cannot be split any further.

The C&R Tree [3], [9] is a tree-based classification and prediction method. Similar to C5.0, this method uses recursive partitioning to split the training records into segments with similar output field values. C&R Tree starts by examining the input fields to find the best split, measured by the reduction in an impurity index that results from the split. The split defines two subgroups, each of which is subsequently split into two more subgroups, and so on, until one of the stopping criteria is triggered. All splits are binary (only two subgroups).

QUEST [9] is a binary classification method for building decision trees. A major motivation in its development was to reduce the processing time required for large C&R Tree analyses with either many variables or many cases. A second goal of QUEST was to reduce the tendency found in classification tree methods to favour predictors that allow more splits; that is, continuous predictor variables or those with many categories.

The target variable for the decision algorithm whether a particular item to that cluster (Two-step algorithm). The best models of decision trees were chosen based on the Evaluation (see Fig. 2) which shows that, as seems to be a model the decision tree algorithm based on algorithm C 5.0.

**Fig. 2: Comparison of different decision algorithms with the use of the evaluation chart.**

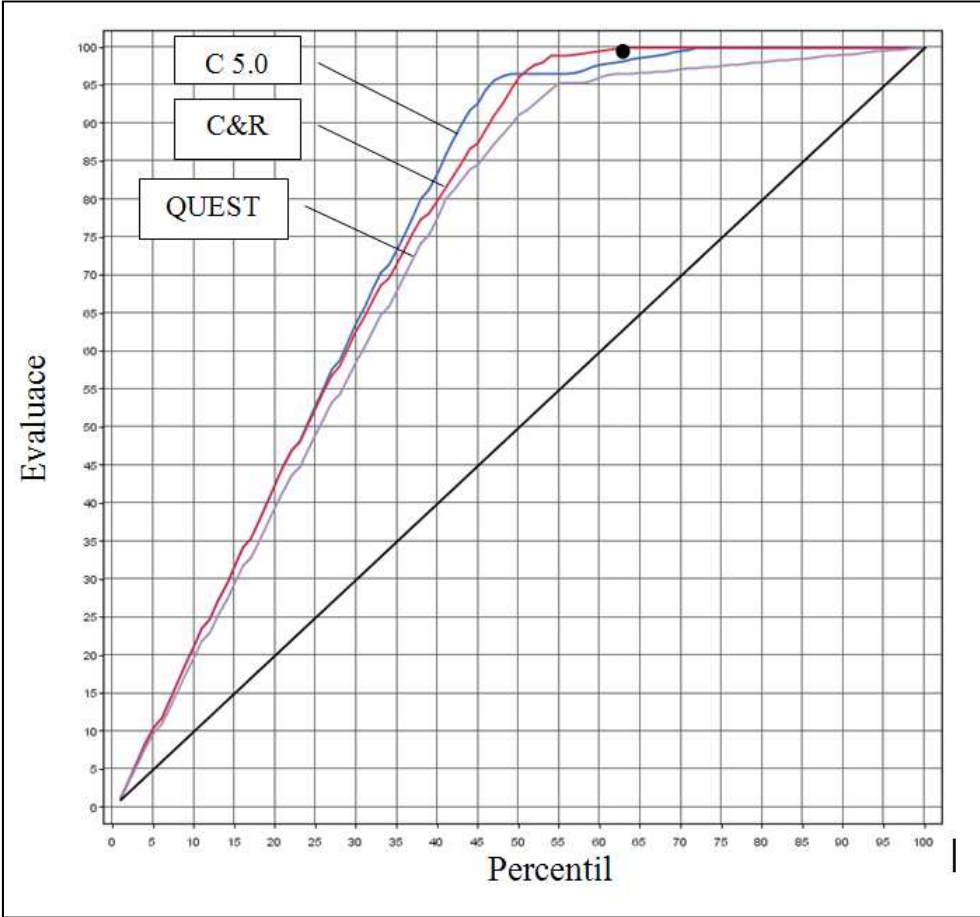

*Source: own*

The algorithm C&R Tree achieved 100% accuracy of classification as the one at 62% percentile. Therefore, this algorithm was chosen as a suitable explanation for the clustering analysis. The analysis resulted in the decision trees algorithm using C&T Tree is following a model (Fig. 3) that suggests how to weight the individual characteristics of the assignment to a cluster that generated the Two-Step algorithm.

Fig. 3: The decision tree generated by algorithm C&T Tree

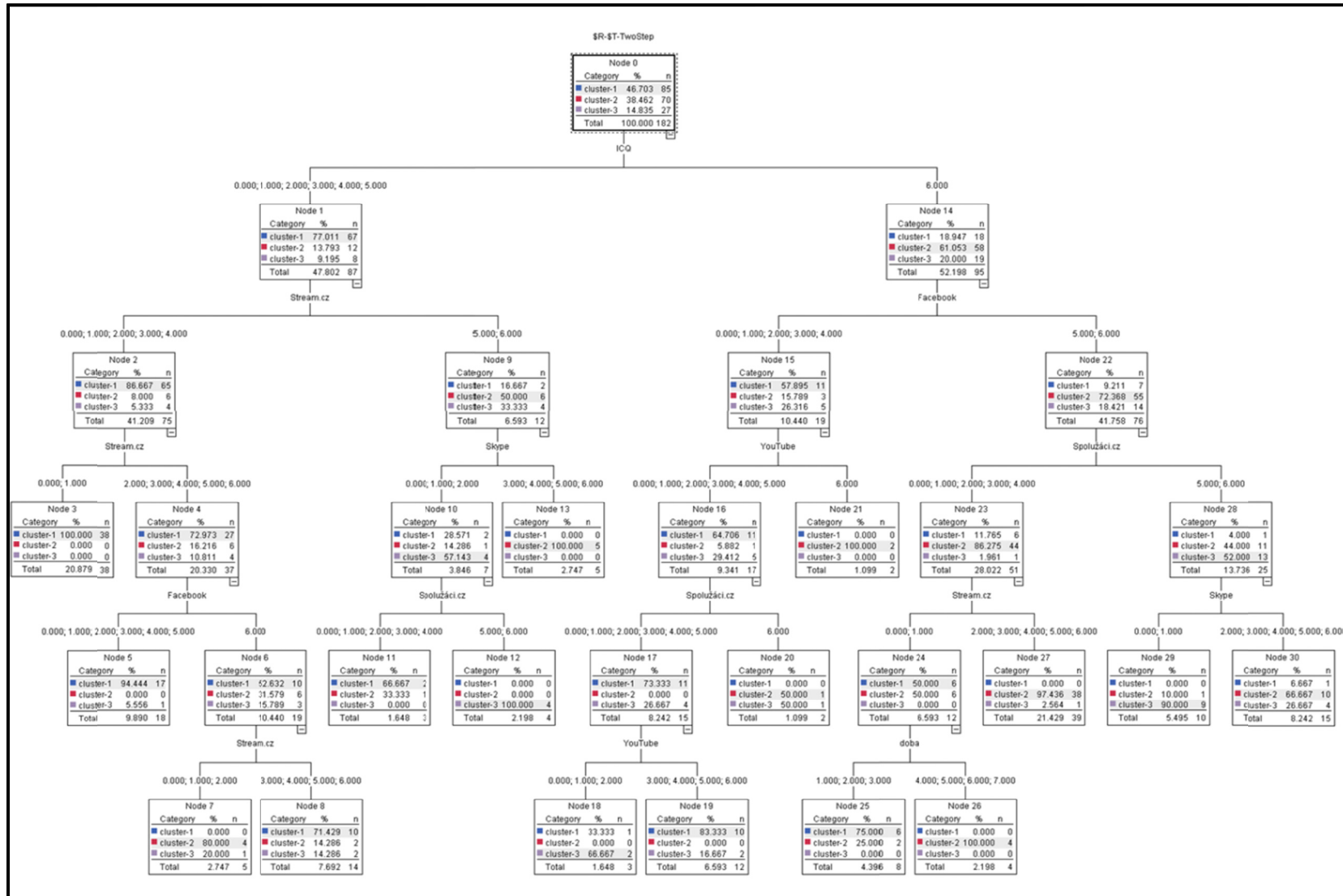

Source: Own

## Conclusion

Respondents, the students of the Faculty of Economics and Administration, can be divided into three clusters.

For the first cluster is characteristic that it is dependent on sex and grade. This cluster does not use any dominant communication network. Respondents prefer a communications network ICQ for daily communication. Skype is used in exceptional cases, but several times a year. However, rather consume media content on YouTube, which is used several times a week. Also this cluster is relatively latent for the Czech social network Spolužáci.cz. Students spend time at the computer between 10-20 hours per week. This cluster is also represented by largest proportion of respondents 85 (46,70%). This is a rather passive group of respondents of social networks overall.

The next cluster contains 70 respondents (38,46%), second in size. Typical for respondents in this cluster is that it is the most active group on Facebook, 85% of respondents from this cluster is on Facebook on a daily basis. Likewise, the communications network ICQ uses 82% of respondents to the daily communication. It is also the group which is very actively communicates with Skype. This cluster tends to the daily consumption of media content on YouTube. This group also spends relatively a lot of time at the computer 30-40 hours. Also in this cluster is not indicative of gender and grade. Generally, this group is described as very active on social networks.

For the last cluster, which is the smallest with 27 respondents (14,83%) is the dominant female. ICQ is very powerful tool for daily communication in this group. On other hand they almost do not use Skype. Furthermore, this group of respondents is the most active in the Czech social network Spolužáci.cz. And every day this group consumes media content on YouTube. Average time spent by this group of respondent at the computer is 35 hours per week.

Therefore, for better understanding how Generation Y communicates with each other, we plan further research to compile a real social network that will confront the type of communication a real meeting of students at the University of Pardubice and communication through computer networks. The Fig. 4 is a social network created by students themselves. Only black spots represent men and two tone (black and white) spots represent women.

**Fig. 4: The social network of students who participated in the research Generation Y at the University of Pardubice.**

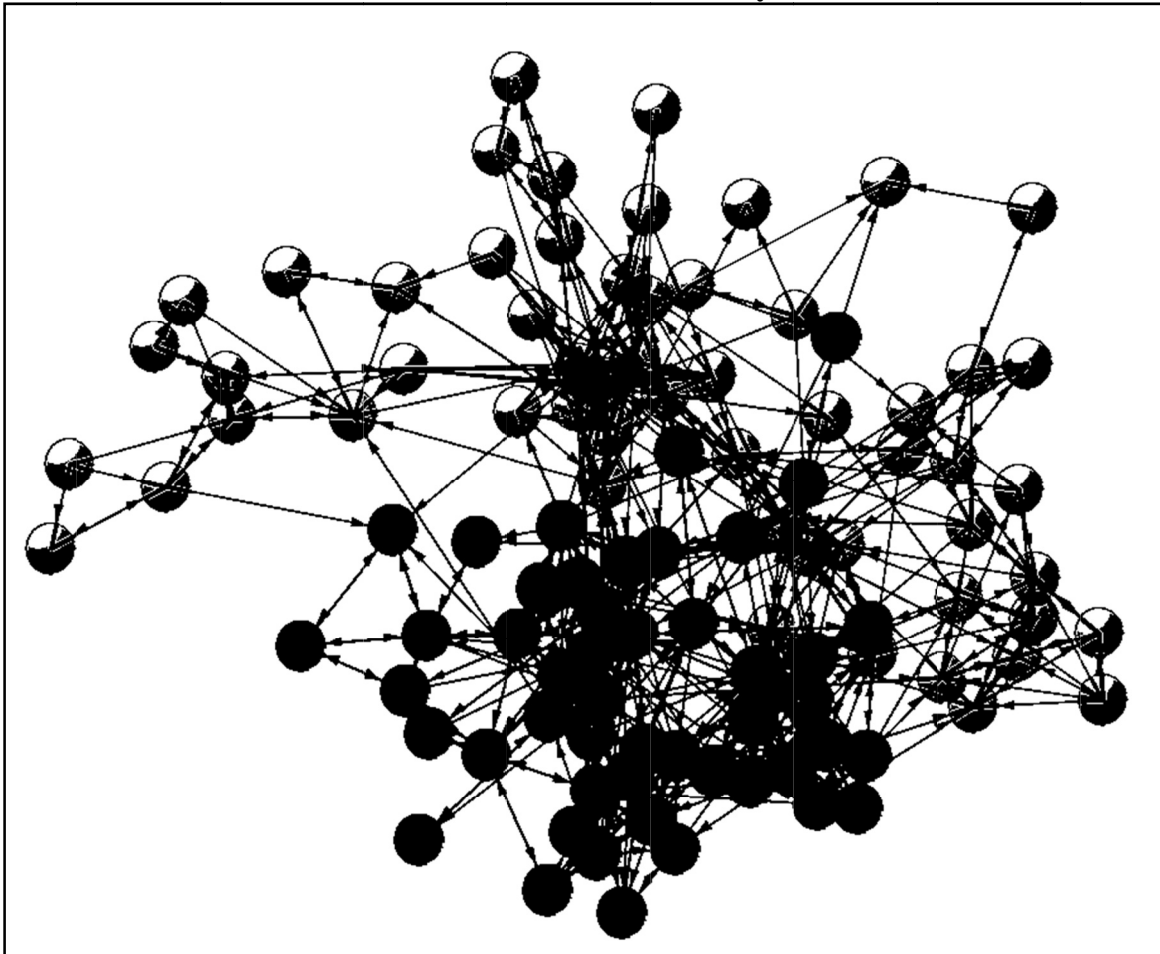

Source: own

Number of return questionnaires were not great (approximately 30%), this was because a pilot survey. We try to motivate students to respond to both questionnaires and completing paying closer attention. The aim of this article was to describe structure of the social network of Faculty of Economics and Administration students by cluster analysis tools.

## References

- [1] BAATARJAV, E., PHITHAKKITNUKON, S., DANTU, R. *Group Recommendation System for Facebook*. On the Move to Meaningful Internet Systems: 2008 Workshops: OTM 2008 Workshops, Springer-Verlag Berlin, Heidelberg, 2008. Volume 5333/2008, 211-219, ISBN 978-3-540-88874-1
- [2] COVEY, N. *How Teens Use Media*. The Nielsen Company. [online] June 2009. [cit. 15.8.2010] Dostupné z www: <[http://blog.nielsen.com/nielsenwire/reports/nielsen\\_howteensusemedia\\_june09.pdf](http://blog.nielsen.com/nielsenwire/reports/nielsen_howteensusemedia_june09.pdf)>
- [3] JOHANSSON, U., NIKLASSON, L., KÖNIG, R. *Accuracy vs. comprehensibility in data mining models*. Seventh International Conference on

- Information Fusion: FUSION 2004. [online] [cit. 10.9.2010] Dostupné z www: <<http://www.fusion2004.foi.se/papers/IF04-0295.pdf> 2004>.
- [4] JONÁŠOVÁ, H., MICHÁLEK, K. *Internetové sociální sítě a Generace Y na Fakultě ekonomicko-správní Univerzity Pardubice*. Scientific Papers of the University of Pardubice, Series D, Faculty of Economics and Administration. 2010, 15, 18, s. 98-107. ISSN 1211-555X.
- [5] JUNCO, R., MASTRODICASA, J. *Connecting to the Net.Generation: What Higher Education Professionals Need to Know About Today's Students*. s.l. : National Association of Student Personnel Administrators, 2007. ISBN 978-0931654480.
- [6] KOHONEN, T. *Self-Organizing Map*. New York. Springer, 2001. ISBN 3540679219
- [7] MACQUEEN, J. B. *Some Methods for classification and Analysis of Multivariate Observations*. University of California Press, 1967. MR0214227.
- [8] MORGAN, J. R. *C4.5: Programs for Machine Learning*. Quinlan, Kaufmann Publishers, 1993. [online] 2010. [cit. 1.10.2010] Dostupné z www: <<http://www.find-docs.com/Quinlan-J-R-C4-5-Programs-for-Machine-Learning%09Morgan-Kaufmann-1993.html>>
- [9] SPSS . Inc., Clementine 10.1 . User Guide. SPSS Inc. 2010.
- [10] STRAUSS, W., HOWE, N. *Generations: The History of America's Future, 1584 to 2069*. Harper Perennial, 1992. ISBN 978-0688119126.

## Contact Address

**Ing. Hana Jonášová, Ph.D.**

**Ing. Karel Michálek, Dis.**

**Ing. Jan Panuš, Ph.D.**

University of Pardubice, Faculty of Economics and Administration, Institute of System Engineering and Informatics

Studentská 84, 532 10 Pardubice, Czech Republic

E-mail: hana.jonasova@upce.cz,

karel.michalek@gmail.cz

jan.panus@upce.cz

Phone number: +420 466 036 074, +420 466 036 001

Received: 30. 09. 2011

Reviewed: 02. 05. 2012

Approved for publication: 03. 05. 2012

# ANALYSIS OF EUROPEAN UNION COHESION

**Pavla Kot'átková Stránská, Tomáš Lelek**

**Abstract:** *The European Union is formation of 27 states at the present. The similarity of the EU member states with the nature of the integration process contributes to successful action in the diminishing of differences and creating a sense of belonging among together. The aim of the article is to examine similarity of EU member states, which can show the integration process success.*

*The European Union should be a whole that can build its growth on the joint development of welfare in reducing economic disparities. The article examines if EU is not only disorderly group of states whose consistency is maintained artificially by political decisions. Politics has seemed to be the most influential representatives of the States in two last years. This implies the idea associated with the fact that in order to progress in the integration process, the individual member states are gradually forced to give up sovereignty in execution of their own economic policy. In the case of disorderly economic development in member states it can happen that, they cannot use the tools of economic policy in such way that is needed to address their own economic situation.*

**Keywords:** *Cluster analysis, European Union, European Union Cohesion, Real GDP growth rate, General government gross debt.*

**JEL Classification:** *E20, E23.*

## Introduction

The European Union is formation of states, which is the result of nearly more than 60 years of the ongoing integration process. This process involves many areas, especially economic and political, which were one of its main causes. In the integration process beginning there were the post-war France and Germany. First integration formation called the European Coal Steel Community was established in 1951. It comprised six Western Europe developed countries. Since those times this formation was transformed and has got seven-times more member states. The Western European integration has achieved high integration level. Nowadays it is in realization of penultimate integration level - full economic and monetary union.

The Eurozone problems have occurred with debt crisis in two last years. It has started discussion about at least of disunity European Union states (EU). This hidden tendency was confirmed by separatist stance of Great Britain and the Czech Republic in the EU Summit on 9<sup>th</sup> December 2011. The principle of solidarity is far more used within the EU economic policy in comparison with the first decade of the 21<sup>th</sup> century. This is one main reason for EU desintegration tendencies increasing. Why do have states with more efficient economic performance endow less powerful and irresponsible ones (eg. Greece).

The politician action in the provision of economic assistance is justified by appeals to the solidarity of economically stronger states with weaker ones, in some cases even irresponsible farming. There is also preferred view on the EU economy as a whole, which could be seriously threaten by small problem part.

Economic cohesion in the EU is thus supported mainly by policy measures, rather than based on a similar development and sense of belonging of the member states. Opinions of the euro area future, respectively the EU are very different. According to prof. Klaus can be expected 10 years of economic stagnation in the EU Member States [3]. Skeptics according to their negative scenarios are used to talk about the possible abandonment of the achieved levels of integration, or even the disintegration of the EU.

Article responds to the currently topical issue of consistency among the EU member states. The angle of view is not political or security - strategic aspects, that are within the economic policy is constantly emphasized, but rather economic. Political will may for a long time to replace the functioning of the natural order and faire laws [15]. But it can not provide effectiveness and prevent a different economic development and non-fulfillment of real convergence in many different aspects of a whole, which the EU undoubtedly is.

## **1 Objective and Methodology**

The main article objective is to analyze the similarity of the EU member states on the evolution of selected variables. The hypothesis is defined for this purpose. Its validity is examined by using multivariate statistical methods.

The hypothesis  $H_0$  states that: "EU member states are under the influence of EU economic policy similar to the development of selected economic variables." In case of hypotheses validity confirmation (hereinafter " $H_0$ " indicating the null hypothesis) can be said the following claims. Thanks to the integration process and the implementation of common economic policy of EU member states, the EU is relatively compact economic unit.

In case of the null hypothesis rejection the alternative hypothesis will be valid. This hypothesis state: „Then integration process and performance of common economic policy has no effect on real macro economic indicators. The success of the integration process and common policies can manifest itself more in the qualitative (removal of administrative barriers, quality of life, etc.)“. These achievements of course contributed to the completion of a common market based on free movement and allow next stages of integration process, but don't remove disparities in economy.

The core category, on which null hypothesis is built, is a similarity. Similarity is quantified on empiric data and used methods. Using the cathegory of similarity has several reasons. The first is the semantic meaning of the word itself. „Similar“ means that the object in comparison with the other evaluation one has most characters the same or only slightly differing. For example, in some relatively minor attributes. The second reason is based on logical deduction. The similarity of objects means that between them are only small differences. Differences are also engaged in regional



science policy and regional development. Too big differences among individuals and territories may lead to serious social and political problems. [8]

The persistence of significant differences leads to a very small willingness of individual parts of the whole to maintain cohesion. Consistency, especially the territorial one means solidarity, cooperation and effective use of territorial potential in order to provide balance, sustainable development and competitiveness of the territory. [9]

The similarity of the EU member states deals strongly with the nature of the integration process. Its successful work in reducing differences and creating a sense of member states belonging should contribute to the cohesion of the EU as a whole. The whole, which can build on the joint development to prosperity in reducing economic disparities. In contrast of this is vision of disorderly grouping, whose cohesion is maintained artificially by political decisions of the most influential member states.

Another article benefit is to determine, which member states groups are simile and how strong links are between these groups. In the case of strong ties can be assumed joint advocacy of these countrie's groups aims. There will be identified and tracked states with the largest economic performance in the EU, which should be uniform in their behavior to maintain a minimum level of integration achieved.

## 2 Cluster analysis

The term cluster analysis was first used by Tryon, in his work in 1939. According to Tryon cluster analysis involves several different algorithms and methods that group objects of similar kind into respective categories. [15] The cluster analysis leads to the examiner's analysis, which uses its instruments to objects classification into groups, in order to create group with maximum degree of connection. The maximum degree of connection means the shortest distance among objects of cluster. Objects having a les degree of connection, will belong to another group. Cluster analysis can not be considered as standard statistical test, since it is a collection of different algorithms, which aims to group objects according to similarities based on defined assumptions.

The output of cluster analysis is horizontal or vertical hierarchical tree fence, called dendogram. Groups of objects are known as so-called clusters. If we want to distinguish the individual clusters, there must be taken into account the element of distance. The most common and most widely used method of calculating the distance between the clusters is Euclidean distance. This is the geometric distance in multidimensional space and the calculation by formula 1 [11].

$$d(x, y) = \sqrt{\sum_{i=1}^n (x_i - y_i)^2} \quad (1)$$

Subsequently it is the necessary to chose clustering method. When statistical software is used, it is recommended to use the method of weighted average of groups pairs. The principle of this method is to take into account the obvious nature of clusters and number of objects in the cluster is taken as a weight. This method is recommended in case of cluster inequality suspicion.

These are following criteria selected into cluster analysis:

- Real GDP growth rate in %;
- employment rate (age of group 16-64 years) in %;
- inflation rate in %;
- public finance deficit to nominal GDP in % (negative values);
- public debt to nominal GDP in % (positive values);
- index number of college students in % (measured as the ratio of the number of college graduates to total population);
- index of the relationship with other countries in % (measured as the balance of payments balance to nominal GDP in %).

Data for cluster analysis were taken from the source database Eurostat and the Organisation for Economic Cooperation and Development (OECD).

Empirical data were inserted into the software product STATISTICA, which made their standardization and subsequently performed cluster analysis based on selected criteria and parameters set for clustering.

### **3 Cluster analysis results**

The longest possible period of 16 years is selected due to data availability and relative unencumbered data of anomalies. The European Union has reached between years 1994 - 2010 the largest expansion. Monetary union was achieved and the end of the period is marked by the economic crisis. Time series data are divided into four periods, that were defined in the context of the historical EU development.

Graphical output, consisting of dendograms and column charts, is chosen for better and more comprehensive interpreting and presenting the results of cluster analysis within each period. This article cannot include all examines period, because of its given length. It consists of two last periods which have the most influence on EU development. Previous periods are mentioned only for addition of examination.

#### **3.1 Period 2004-2008**

This period is characterized by the largest EU enlargement by 10 countries of Central and Eastern European initially with transition economies. Moreover Romania and Bulgaria has joined in 2007. The EU includes now 27 members who have in terms of political regime and economic system different past. There are problems with the budgetary discipline of member states and the vast majority of the eurozone members is not able to fulfill the Maastricht criteria or the Stability and Growth Pact.

**Fig. 1: Median values of selected criteria of the EU member states in the period 2004 – 2008**

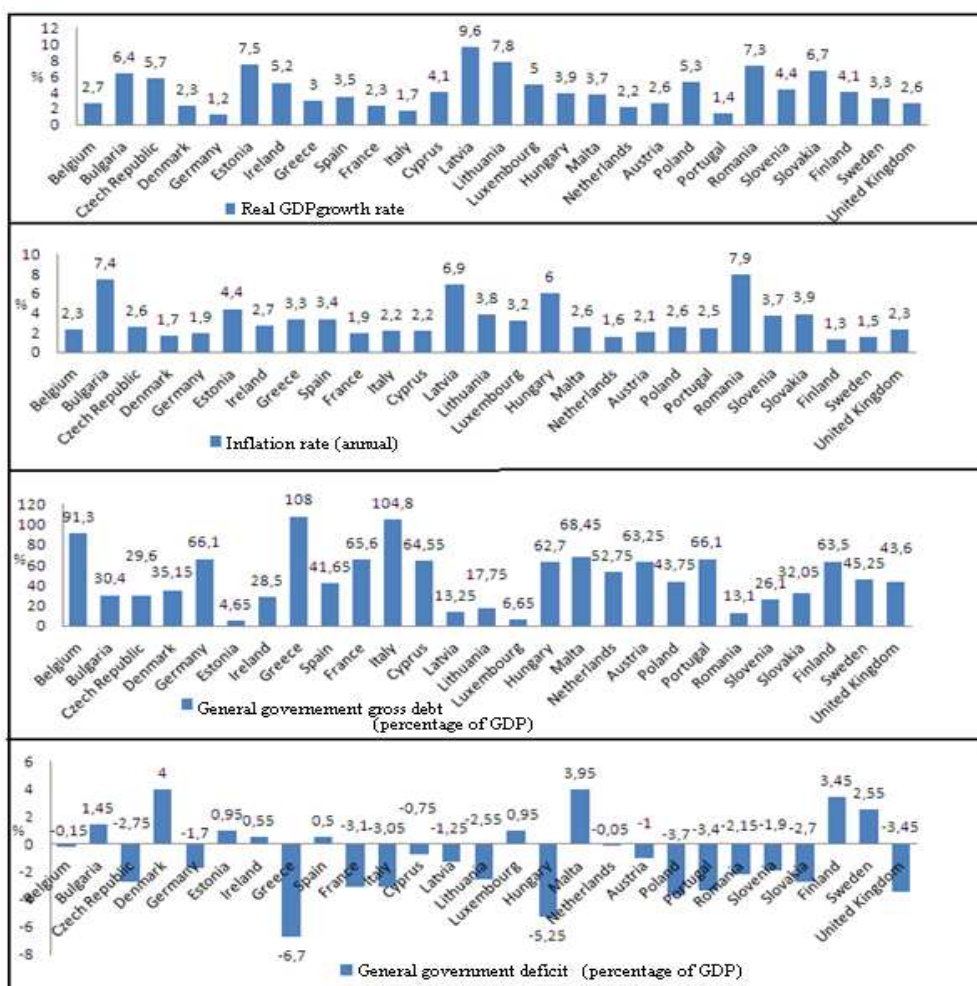

Source: own according to [13]

Figure 1 shows the GDP growth rate of newly admitted member states. It is well above the average of the optimal value of 3% set by OECD. Moreover, in comparison with the other member states is much higher. Looking at the rate of inflation it can be found that the vast majority of these states has got a value far above the optimal limit of 2% (5-8%). The ratio of public debt to GDP of these countries had since 2000 a downward trend (Estonia, Latvia). Thus inflation rate increasing can be attributed rather to monetary area.

**Fig. 2: EU member states dendrogram in the period 2004 - 2008**

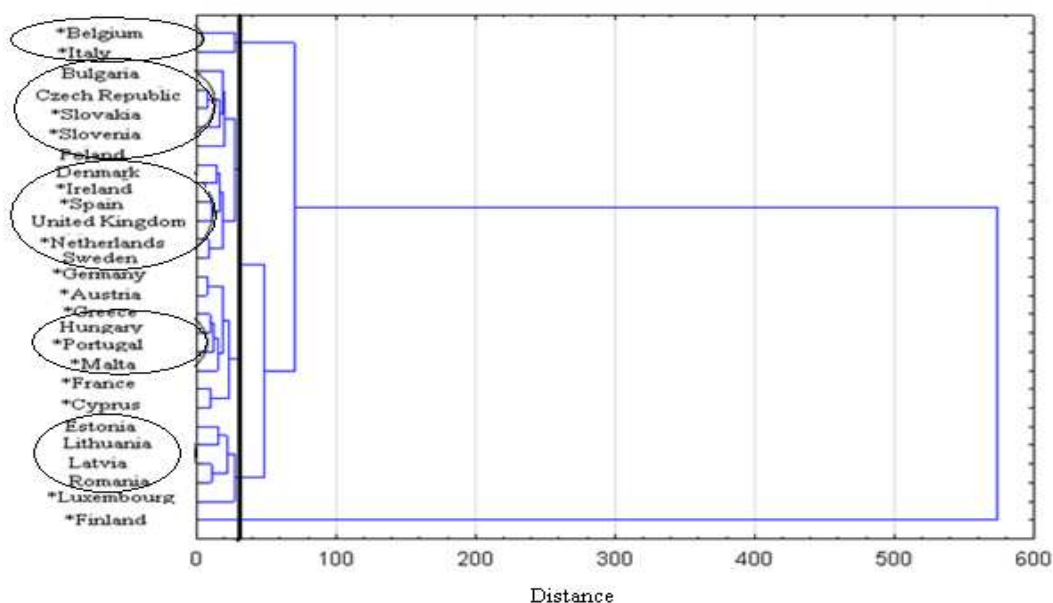

*Source: own according to [13]*

Cluster analysis result is with four clusters same as in former period. They differ in its composition, because of the newly admitted states (Fig. 2). States with star in front their names belong to eurozone. They show similarity in eurozone. Greece is moving from the cluster including Italy, which represents the third most powerful EU economy. Greece moves to cluster with less powerful economy, e.g. Portugal. In this period there is a merger of two groups of economically powerful states in the group consists of UK, Ireland, Denmark, the Netherlands, Sweden. This cluster also includes Spain, because it reaches like other countries in the cluster corresponding growth rate of real GDP output (median of the period is 3.2), as well as fulfilling the Maastricht fiscal criteria. Moreover employment is on the same level as in other states. The only criterion that Spain may push the edge of the cluster and separate the latter is the criterion of balance of payments deficit to nominal GDP, where the latter reaches the median for the period of 9%. The similarity of Germany and France is shown again. But the relationship strength between them is weaker than in the previous period.

### **3.2 Period 2009-2010**

Financial crisis has broke out at the end of 2008. It has reflected by worsening macro-economic data in developed Western economies (EU, USA) during 2009. Countries with deep impact of the economic crisis has increased governmental spending and enacted laws supporting the demand for key products industry.

**Fig. 3: Median values of selected criteria of the EU member states in the period 2009 - 2010**

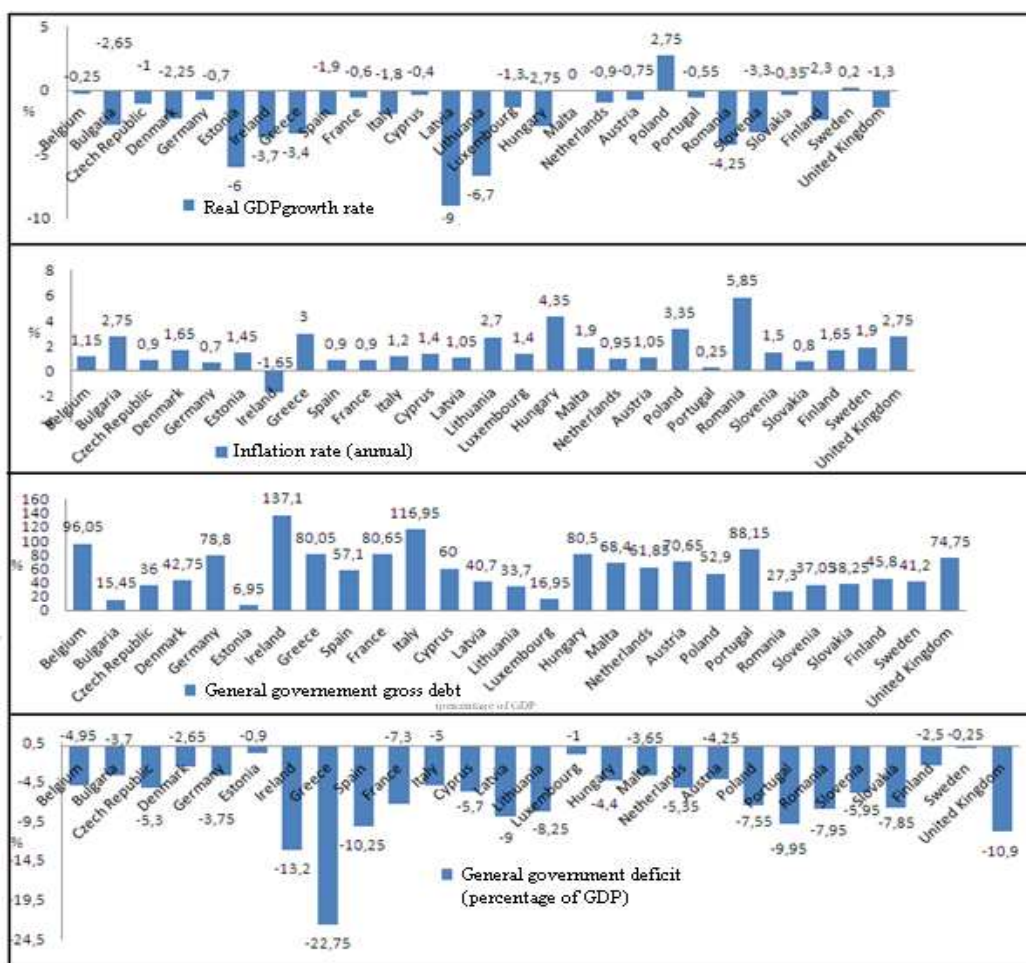

Source: own according to [13]

GDP growth rates significantly dropped during this period (Fig. 3). Especially those, which had have the highest growth rate in the previous period (Latvia, Estonia). Public debt rose most in Ireland and Italy. Most member states does not meet the Maastricht criteria with long-term values of 60%.

This leads to the question, what is the nature of the relationship between the variables of real GDP growth rate and public debt as a share of nominal GDP.

$$Real\ GDP\ growth\ rate = \frac{GDP_t - GDP_{t-1}}{GDP_{t-1}} \times 100 \dots [\%] \quad (2)$$

$$General\ government\ gross\ debt = \frac{General\ government\ gross\ debt_t}{nominal\ GDP_t} \times 100 \dots [\%] \quad (3)$$

Based on the principle of calculating these variables (see formula 2, 3) it can be suggested, that the development of real GDP and the share of public debt to nominal GDP have inverse relationship. In addition, usually rising price level is captured in the inflation rate and further supports this relationship. However, this is not clearly reflected in the development of their empirical values. This is evident from the graphical view by using the point graph with marked generally recommended values

3% of GDP growth rate and 60% of public debt corresponding to the Maastricht criteria (see Fig. 4).

Period 2004 - 2008 confirms, that the higher the GDP growth rate is, the more possible is to observe total debt decreasing. This is in keeping with Keynesian policy of increasing government spending during the downturn in economic performance [17].

The last period is marked by economic crisis and GDP growth rates sharp reduction. EU member states are equally placed above and below the line representing 60% of total debt. Examined relationship of GDP growth and debt cannot be clearly characterized due to different trends of individual countries. Luxembourg is worth noting, because his debt was below 60% in all the periods and ranked among the countries with overall slightly above-average economic performance relative to other states.

**Fig. 4: Real GDP growth rate and general government gross debt in the period 2004-2008 and 2009-2010**

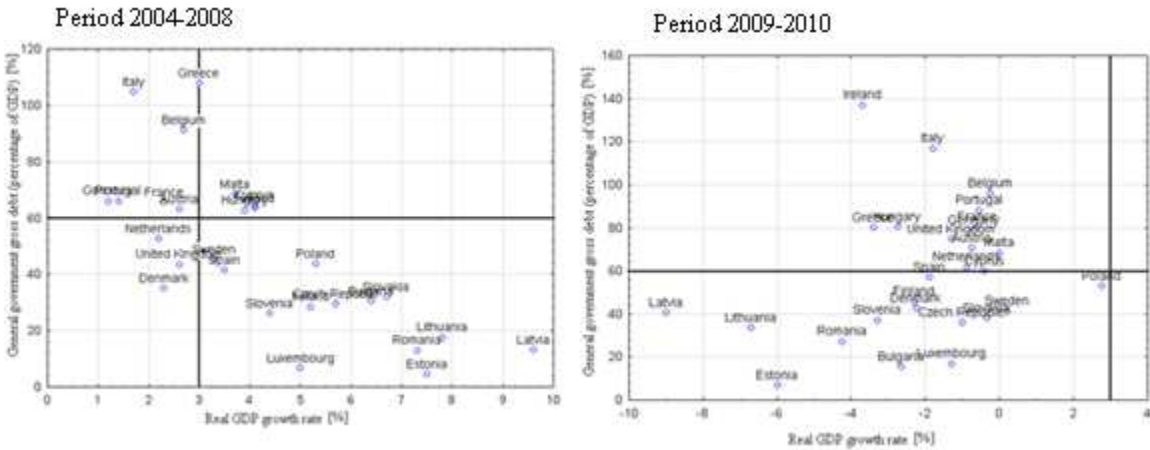

Source: own according to [13]

From the ambiguous economic development, partly due to the different reactions of the Governments of the member states is apparent failure of fiscal discipline and moral irresponsibility of the individual states for their impact on the status of the integration formation.

**Fig. 5: EU member states dendrogram in the period 2009 - 2010**

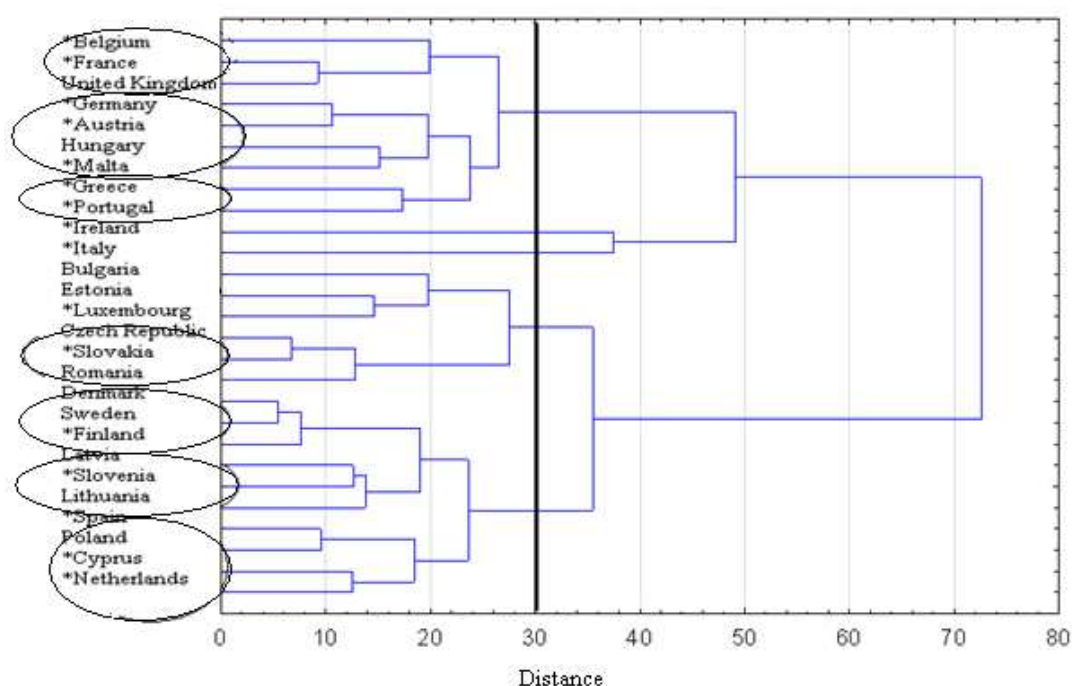

*Source: own according to [13]*

The number of observable clusters grown at double in comparison with the previous period (see Figure 5). Individual clusters represent a lower number of states. Greece gets into the cluster with Portugal. These countries went to troubles. Another one cluster consist of the Scandinavian countries. It is apparent dominance segregation by values corresponding to more underlying economic situation in individual countries before the EU admitting.

The EU is exposed to the economic crisis which manifested itself in 2009. Governments of the member states as well as the European Central Bank have used their instruments in expansionary policies to mitigate crisis impact. It has deepend debt and a fall in GDP, which has unleashed problems for eurozone due to Greece. After the financial and economic crisis, the debt crisis occurs. The solution should lie in changes in the Treaties and finding system tools, than the violation of basic economic rules and loss of credibility of the euro area leading to disunity within the EU. Divisions on the euro area is also apparent from Fig. 5, when these states spread unevenly in different clusters.

## Conclusion

Each state in a given period behaves relatively independently. Instead of decreasing clusters number as evidence of economic integration success and real convergence, can be seen increasing of different groups number during two last reporting periods. The null hypothesis set at the beginning can be disprove due to this facts. Alternative hypothesis can be accepted. The process of integration and performance of common economic policy has no effect on real macro economic indicators. The success of the integration process and common policies can manifest itself more

clearly rather in the qualitative aspects (removal of administrative barriers, quality of life, etc.).

It is paradoxical that in comparison of clusters in the periods 2004 – 2008 their number did not increase, even though the EU has grown by 12 states. On the contrary, during a relatively short period 2009 - 2010 the number doubled. According to the analysis it can be suggested that one of the causes of larger clusters number appearance is the minimum similarity of individual member states. Due to the manifestation of the crisis in the fiscal area was also to highlight the inconsistency of individual states. In addition, this internal division may be one of the causes of disintegration tendencies manifesting inconsistency and disruption of the EU as a whole.

The economic crisis has reflected in economic reality, which revealed a previously underserved obvious problems, particularly in the fiscal area among the member states and calls for immediate response to the economic policies of the EU offering a system solution. In times of economic crisis, which should be considered as an empirical phenomenon repeated in about 80 year periods, showed very little similarity between the economic development of states. The occurrence of the paradox can not automatically attribute to an exceptional event. In the case of the European Union, the authors believe that the economic crisis played a role rather a kind of catalyst to accelerate reactions leading to a decrease in cohesion of the EU as a whole.

The analysis of macroeconomic data doesn't show positive effects of integration, particularly in the last stages (common market and economic and monetary union). In addition, due to failure of fiscal discipline and inconsistency of the EU Member States is also weakened external competitiveness of the EU, eg. with as the United States.

The EU example shows that to ensure consistency of this large economic unit is very difficult. The question is whether preparing the fiscal union can bring tendency to reduce the enormous debt of member states. Due to the tradition of violations Maastricht criteria and reluctance of member states to follow fiscal discipline, its effects may not occur in practical. Nowadays negotiation about fiscal union leads to separation of countries, which don't want to automatically accept certain disadvantages (Great Britain and the Czech Republic).

Waiver of autonomy in using the tools of monetary and fiscal policies also will lead to further loss of national sovereignty to European institutions in the future. Furthermore, it may affect one of the common EU economic policies principles - the principle of subsidiarity. In case of worse economic development persistence it should certainly cause distrust in the EU and strengthen nationalism and disintegration tendencies (see Finland, Hungary). The authors believe that the success of EU cohesion should be firstly based on loyalty and member states willingness to the growth of the whole. Unfortunately, this political formation, paradoxically, has no distinctive symbols and statesman with whom individual states, respectively citizens could be identified.



## References

- [1] BLAŽEK, J. Regionální vývoj a regionální politika: hlavní přístupy v zemích západní Evropy. In *Sýkora, L. ed.: Teoretické přístupy a vybrané problémy v současné geografii*. Praha: Univerzita Karlova v Praze, Přírodovědecká fakulta, katedra sociální geografie a regionálního rozvoje, 1993, s. 120-146.
- [2] BLAŽEK, J., UHLÍŘ, D. *Teorie regionálního rozvoje*. Praha: Nakladatelství Karolinum, 2002.
- [3] ČTK. Klaus: *Euro přežije, Evropa ale zaplatí stagnací*. [online]. [cit. 2012 -02-01]. Available at WWW: <<http://zpravy.e15.cz/zahranicni/ekonomika/klaus-euro-prezije-evropa-ale-zaplati-stagnaci-711737>>.
- [4] DRAESSLER, J., SOUKAL, I., HEDVIČÁKOVÁ, M. Shluková analýza poptávkové strany trhu základních bankovních služeb. In *E+M Ekonomie a Management*. 2011, roč. 14, č. 4, s. 102-113. ISSN 1212-3609.
- [5] Databáze Eurostat. [online]. [cit. 2011 -11-01]. Available at WWW: <<http://epp.eurostat.ec.europa.eu/portal/page/portal/statistics/themes>>.
- [6] Databáze Eurostat.cz. [online]. [cit. 2011 -12-01]. Available at WWW: <<http://apl.czso.cz/ode/index.htm>>.
- [7] HEBÁK, P. A KOL. *Vícerozměrné statistické metody*. 1.vyd. Praha: Informatorium, 2005. ISBN 80-7333-039-3.
- [8] HINDLS, R., HRONOVÁ, S., SEGER, J., FISCHER, J. *Statistika pro ekonomy*. 8.vyd. Praha: Professional Publishing, 2007, s. 420. ISBN 978-80-86946-43-6.
- [9] HYSKÝ, M. *Diskuze k Zelené knize územní soudržnosti*. [online]. [cit. 2011 -12-11]. Available at WWW: <[http://ec.europa.eu/regional\\_policy/archive/consultation/terco/pdf/3\\_region/56\\_vysocina\\_cs.pdf](http://ec.europa.eu/regional_policy/archive/consultation/terco/pdf/3_region/56_vysocina_cs.pdf)>.
- [10] KRAFTOVÁ, I., KUBANOVÁ, J. Využití shlukové analýzy při deskripci firem regionu s akcentem na jejich produktivitu a kapitálovou sílu. In *E+M Ekonomie a Management*. 2003, roč. 5, č. 4, s. 87-92. ISSN 1212-3609.
- [11] KUBANOVÁ, J. *Statistické metody pro ekonomickou a technickou praxi*. 1.vyd. Bratislava: STATIS Bratislava, 2003, s. 247. ISBN 80-85659-31-X.
- [12] MELOUN, M., MILITKÝ J., HILL, M. *Počítačová analýza vícerozměrných dat v příkladech*. 1.vyd. Praha: Academia, 2005. ISBN 80-200-1335-0.
- [13] OECD. Databáze statistik. [online]. [cit. 2011 -12-11]. Available at WWW: <[http://www.oecd.org/document/0,3746,en\\_2649\\_201185\\_46462759\\_1\\_1\\_1\\_1,0\\_0.html](http://www.oecd.org/document/0,3746,en_2649_201185_46462759_1_1_1_1,0_0.html)>.
- [14] PROVAZNÍKOVÁ, R. VOLEJNÍKOVÁ, J. *Makroekonomie – cvičebnice*. Slaný: Melandrium, 2003. 384 s. ISBN 80-86175-28-6.
- [15] VOLEJNÍKOVÁ, J. *Moderní kompendium ekonomických teorií: od antických zdrojů až po třetí tisíciletí*. Praha: Profess Consulting, 2005, s. 378. ISBN 80-7259-020-0.

[16] TRYON, R. C. *Shluková analýza*. New York: McGraw-Hill, 1939.

[17] ŽÁK, M. *Hospodářská politika*. 1. vyd. Praha: VŠEM, 2006, s. 210. ISBN 80-86730-04-2.

### **Contact Address**

#### **Pavla Koťátková Stránská, Ing. Ph.D.**

Univerzita Pardubice, Fakulta ekonomicko-správní, Ústav ekonomických věd  
Studentská 84, 532 10 Pardubice

Email: pavla.kotatkovastranska@upce.cz

Tel. číslo:+420 46 606 161

#### **Tomáš Lelek, Ing. Ph.D.**

Univerzita Pardubice, Fakulta ekonomicko-správní, Ústav ekonomických věd  
Studentská 84, 532 10 Pardubice

Email: tomas.lelek@upce.cz

Tel. číslo:+420 46 606 477

Received: 26. 04. 2012

Reviewed: 26. 07. 2012

Approved for publication: 01. 11. 2012

# CREATING A CONTEXT AS THE BASE FOR ENTREPRENEURIAL SUPPORT POLICY

Ivana Mandysová

**Abstract:** *This study advances knowledge in the field of entrepreneurship policy and lays out a path for policymakers to follow. It highlights some of the major challenges faced by governments in evaluating the impact of policies and measures geared towards producing higher levels of entrepreneurial activity and discuss the potentially conflicting perspectives of entrepreneurs, policymakers and service providers. In this study we present the findings of entrepreneurship support policy stated in author's monograph [8] including theoretical background of entrepreneurship support policy and its policy foundations and entrepreneurship policy framework. We discuss conceptual issues related to steps identifying entrepreneurship policy measures; the appropriate choice of entrepreneurship support policy options and several issues concerning the improvements of entrepreneurship policies and programs. We introduce the **Context model for Entrepreneurial Support** that may be useful to government in taking stock of its current policy orientation and to better enable the assessment of entrepreneurship policy across country. We conclude with a discussion of how to approach the development of an integrated entrepreneurship policy approach and the future implications of this for policymakers, researchers, and economic development agents.*

**Keywords:** *Entrepreneur, Entrepreneurship, Entrepreneurial support, Entrepreneurship Policy, Policy Measures.*

**JEL Classification:** *L26, L53.*

## Introduction

We can recognize entrepreneurship as first and foremost a mindset. To find an entrepreneurial opportunity, one needs to have a taste for independence and also to be prepared to handle the uncertainty. Entrepreneurs need to be able to transform opportunity into economic value and to match their creativity and knowledge with a strategic vision and company management. [4]

Entrepreneurs are considered as the vehicle for the commercial exploitation of innovative and creative ideas. They play a key role in the European Union boosting competitiveness and dynamism. [3]

In February 2004, the European Commission presented its agenda for entrepreneurship. This action plan sets the priorities for fostering entrepreneurial performance in the European Union. It emphasizes in the first place the need to encourage more business start-ups by fuelling entrepreneurial mindsets and reviewing the balance between risks and rewards related to entrepreneurship. It also highlights the importance of encouraging businesses development and growth and the key role of finance in realizing this. To rise successful entrepreneurial activity depends on

a complex set of mutually interacting framework conditions, attitudes and skills. In order to make a progress in this field the European Commission identified a list of measures to be taken both at EU and Member States level. Member countries and regions each have a unique mix of strengths and weaknesses affecting their entrepreneurial culture and business environment. These require specific responses, to complete the entrepreneurship support agenda, there still is a way to go.

## **1 Statement of a problem**

### **1.1 Entrepreneurial support importance**

Importance of the entrepreneurial support policy has been escalating over the past years. The driving force behind this interest is the growing body of research on the relationship between entrepreneurship and economic growth. There is essential contribution of new firms to employment and economic growth [2] influences entrepreneurial activity across countries [7]. This reinforces the critical contribution of new firms to job creation, innovation, productivity and economic growth in an economy.

### **1.2 Growing interest in the entrepreneurial support**

Scientific research findings state that entrepreneurship is important to economies in several ways. The compelling arguments for the importance of small business to the economy was its role in job creation, showed by Zoltan Acs [1]. His research revealed that most of the jobs in the United States were not only being generated by small firms, but by new and rapidly-growing young firms. Research in other countries confirmed the job creating contribution of new and small firms.

Governments in developed countries are paying more recent attention to entrepreneurship policies because of the need for renewal of their economic performance. As part of the restructuring of the „old economy”, many large companies are still moving their production units (and jobs) to locations around the world with lower wages. This trend will likely continue over the coming years as pressure continues to bear on the reshaping of industrial structures. Further declines in the manufacturing sectors of developed economies will be accompanied by growth in the knowledge-based and services sectors where many low-barrier-to-entry opportunities exist for small firms and new start-ups to supply products and services. One of the effects of this restructuring will be a demand for new indigenous firms and growing small businesses to replace lost jobs and economic momentum.

Entrepreneurship is also seen as part of the solution to reducing unemployment levels and absorbing new labor force entrants. Since research confirms the important role of new and young firms in employment creation, future employment growth is likely to come from growth in entrepreneurial activity. Thus, governments are expressing more interest in how to stimulate start-ups and encourage more entrepreneurship.

Stimulating entrepreneurial activity requires a different set of policy imperatives than supporting the maintenance and growth of existing small and medium-sized enterprises. Governments and societies are eager to identify gaps in their existing

policy frameworks or areas that are deficient in meeting the conditions for an environment conducive to entrepreneurship and seeking knowledge about, and a better understanding of, how to do this.

## **2 Theoretical Background and Scientific Research Conceptual Issues**

Researchers have focused on the topic of entrepreneurial support policy apart from the European Union (EU) and the Organization for Economic Cooperation and Development (OECD). The research being done draws from a number of disciplines, such as economics, sociology, psychology, management, and economic geography. Authors [1] [2] explain the rise in entrepreneurship policy formulation as a necessary response to fundamental industrial and economic restructuring - a shift from the „managed economy“ to the „entrepreneurial economy“. Frameworks for analyzing the determinants of entrepreneurship have been proposed [5] [6]. Whether entrepreneurial support policy should have been derived either from the development of theoretical, conceptual frameworks or from findings of research on the experiences and needs of entrepreneurs is the main research question winding throughout the contemporary scientific research.

Shapiro and Audretsch [11] [2] propose an eclectic theory of entrepreneurship that weaves together into an integrated framework aspects of culture, occupational choice, the resources available to entrepreneurs, and the extent of entrepreneurial opportunities in the economy. This framework is intended to provide insights to policymakers striving to promote entrepreneurship. These researchers suggest a number of possible roles for government policy in influencing the level of entrepreneurship at the country level. They distinguish between the supply side and the demand side of entrepreneurship and highlight the different sets of policy interventions available to governments depending on which view is taken vis-a-vis the determinants of entrepreneurship. Influencing the demand side are factors such as the demographic composition of the population, the resources and abilities of individuals and their attitudes towards entrepreneurship. The supply side is influenced by opportunities for entrepreneurship created by new technologies, the differentiation of consumer demand and the industrial structure of the economy. Acs further introduces the concept of actual versus equilibrium rates of entrepreneurship, suggesting the possibility of a predictable relationship between the level of business ownership in a country and its level of economic development (GDP/capita). Pfeffer suggests that the process by which the actual rate of entrepreneurship is established involves both micro and macro components. [10]

On the demand side entrepreneurial opportunities are created by market demand for goods and services, whereas the supply side generates (potential) entrepreneurs that can seize the opportunities, provided they have the resources, abilities and preferences to do so.' The actual rate of entrepreneurship is determined by occupational choice decisions and may deviate from the equilibrium rate due to demand-side forces, such as changes in market structure and technological developments. The discrepancy between the actual rate and the equilibrium rate is expressed through a surplus or lack of entrepreneurial opportunities, which will then lead to either the entry or exit of entrepreneurs. Actual and equilibrium rates can be mediated through market forces,

but governments may also choose to intervene through selected policy measures. [8]  
[9]

### **3 Methods**

In the beginning we discuss and argue why entrepreneurship policy is important, we highlight recent developments in research knowledge about the factors affecting entrepreneurial activity levels and explore state of entrepreneurship policy frameworks.

The purpose of the study is to set priorities and consequences in the policy analysis cycle in the entrepreneurship support policy. It is necessary to articulate entrepreneurial support policy framework and to address gaps and improvements in the existing field of knowledge base. Findings of this article can be useful for government policymakers and researchers and educators. It aims to be a tool to assist policymakers in making the transition to an entrepreneurship policy approach sorting out the clearer separation of initiatives targeted to increasing the level of entrepreneurial activity versus strengthening the environment for SMEs (Small and Medium Sized Enterprises); a base for the research community in identifying key entrepreneurship policy issues worthy of further examination. To fulfill these we need to propose a context for entrepreneurial support base in following steps: to define priority problems to be solved, to define policy objectives, to make selection of measures.

It is our intention to stress in the end the complexities of entrepreneurship increase in the economy. For this reason we propose a „*context model*” (Fig. 4) stressing the influence of individual and summarizing variables influencing entrepreneurship showing results towards macro-economic phenomenon.

### **4 Creating context for Entrepreneurial support and addressing gaps and improvements in the existing field of knowledge base**

It is apparent that government places different weightings of emphasis on areas of the entrepreneurial support policy framework and on specific measures within each of those areas.

We want to stress the point that the configuration of a government's entrepreneurship policy approach appears to depend on a number of contextual factors. These include, among other things, the country's economic structure and level of development, its economic, political and social priorities, the size and role of its government, the views held by government about where growth comes from and what factors lead to it, its levels of unemployment, self-employment and business ownership the rate of its entrepreneurial dynamism.

#### **4.1 Steps identifying policy measures**

##### **1) Isolating the problems to be solved**

There are two basic questions of great importance in deciding on specific policy measures in any area of public policy: a) what are the priority problems that need to be solved; and b) to what extent should public spending programs be used to solve these

problems. (Fig. 1) The application of these questions will help in defining the domain of publicly-financed small business and entrepreneurship policy. These fundamental questions have not been substantively dealt with in evaluation theory. The application of different macroeconomic theories will point to differing public policy roles.

**Fig. 1: Isolating the problems to be solved**

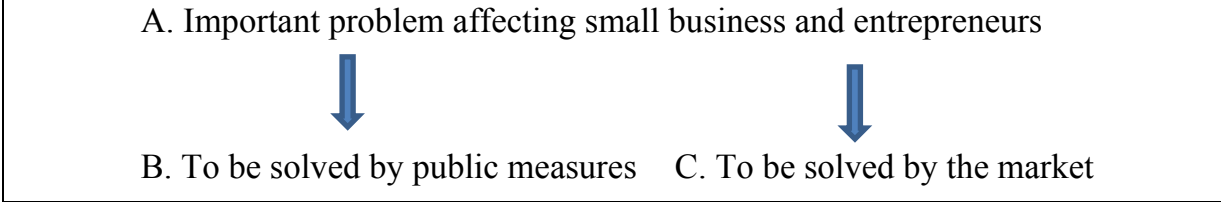

*Source: own*

2) Defining policy objectives

The second step would be to define objectives for the different policy measures to be taken, given the specific nature of the problems to be solved. What objectives should be met by possible policy measures? (Fig. 2) If there is a problem that is supposed to be solved with policy measures then someone also has to decide when that problem is solved. The policy analysis cycle will begin.

**Fig. 2: Defining policy objectives**

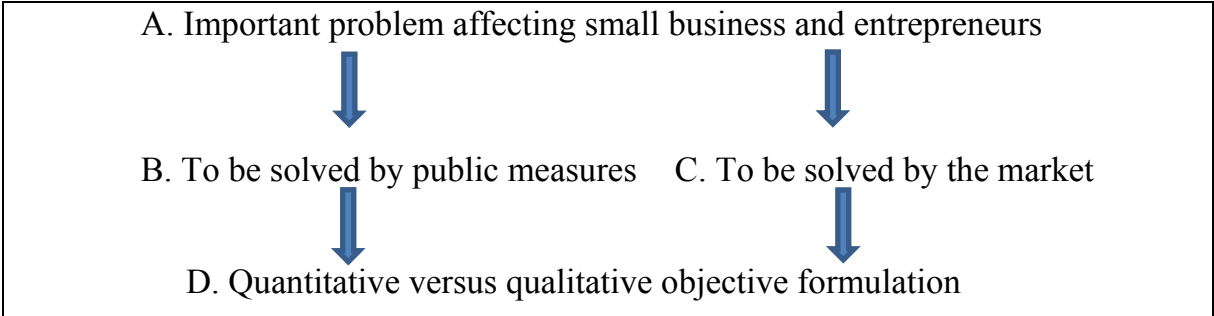

*Source: own*

3) Making the selection of measures

After identifying the objectives, the next step in the process will be to discuss possible policy options, resource requirements and resource allocations. (Fig. 3) There are several alternative ways to achieve a stated objective, often through a combination of different measures. In the entrepreneurship policy area, a number of common measures can be employed depending on the type of problem to be solved. It depends on each type of measure, the level of research-based confirmation that the problem exists, and the types of objectives set for each policy measure. It points to some important issues with respect to entrepreneurship policy formulation. This can be for example, improving access to financing and advice and reducing barriers to entry and creating networking opportunities.

Each type of measure attempts to address its own particular problem. In other words, a general problem formulation could be missing. Objectives set for the different problem areas are mostly of a qualitative nature, such as „increase awareness of entrepreneurship as a career option”.

Many factors have been identified in the research literature as being associated with the entrepreneurial activity in a region. We can identify a lot of influencers, including economic, social and cultural factors, attitudinal factors, e.g., taxation and ease of business entry and exit factors, population, immigration, GDP growth factors, labor market and regulatory factors, the relative size of the public to the private sector: the density of small firms/business owners in the population, and the prevalence of entrepreneur role-models, positive attitudes towards entrepreneurship, fear of failure, risk-taking, etc.,

**Fig. 3: Making the selection of measures**

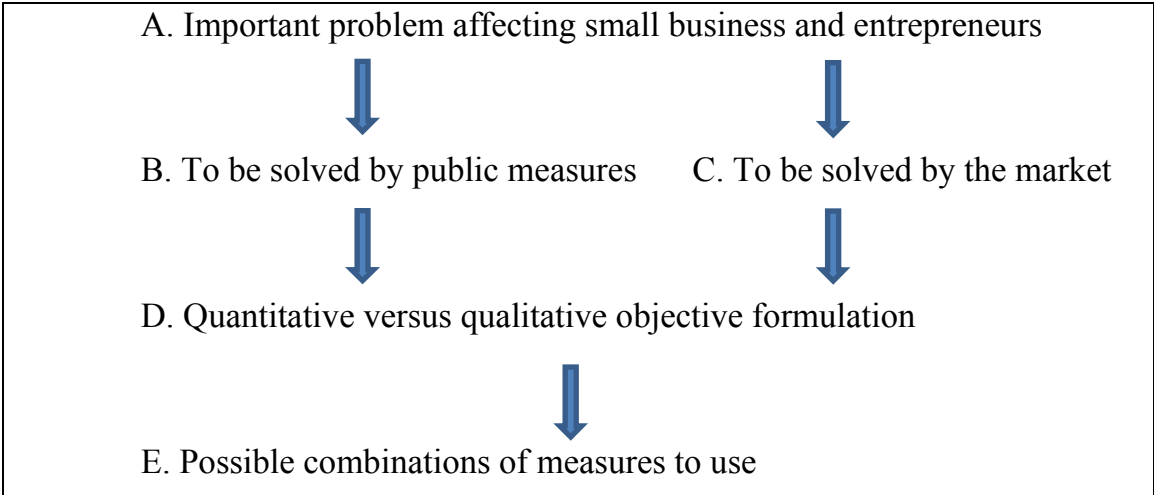

Source: own

**4.2 Addressing gaps and improvements in the existing field of knowledge base**

There has been a *dramatic improvement in the quantity and quality of statistical data on the SME sector* during last decade both in the Czech Republic, held by Czech Statistical Office and in the European Union, held by Eurostat. To capture data on new firm entries and to track the employment growth of new and existing small firms over time has significantly improved our understanding of the impact of new and small firms on the economy. We are able to see that underlying the small incremental net growth in the stock of firms and their net employment on an annual basis is a high level of turbulence. Enterprise situation [12], [13] allows policymakers to see that business turnover and the entry and exit of firms merits their attention. One of the policy implications we can see from these data is that new firms are required to replace exiting firms and to create jobs to replace those lost due to exiting and downsizing firms.

Czech government also has greater *capacity to measure self-employment rates* in the population and to track the entries and exists into and out of self-employment on an annual basis. Combining business registration and self-employment databases allows policymakers and researchers to examine the relationship between firms and individuals and to profile both firms and their owners.

The major gap in the area of entrepreneurship research knowledge base and statistical analysis is the lagging behind development of harmonised methodologies to



measure the level of entrepreneurial activity in the Czech Republic and make credible national comparisons. The Entrepreneurial Activity (TEA) Index, developed as part of the Global Entrepreneurship Monitor (GEM) project, can be an example that could provide standardised measurement of nascent entrepreneur rates, rates of new business entrants and young firm prevalence rates across countries [14].

**4.3 Complexities influencing and resulting “Context model for Entrepreneurial Support”**

*Fig. 4: Context model for Entrepreneurial Support*

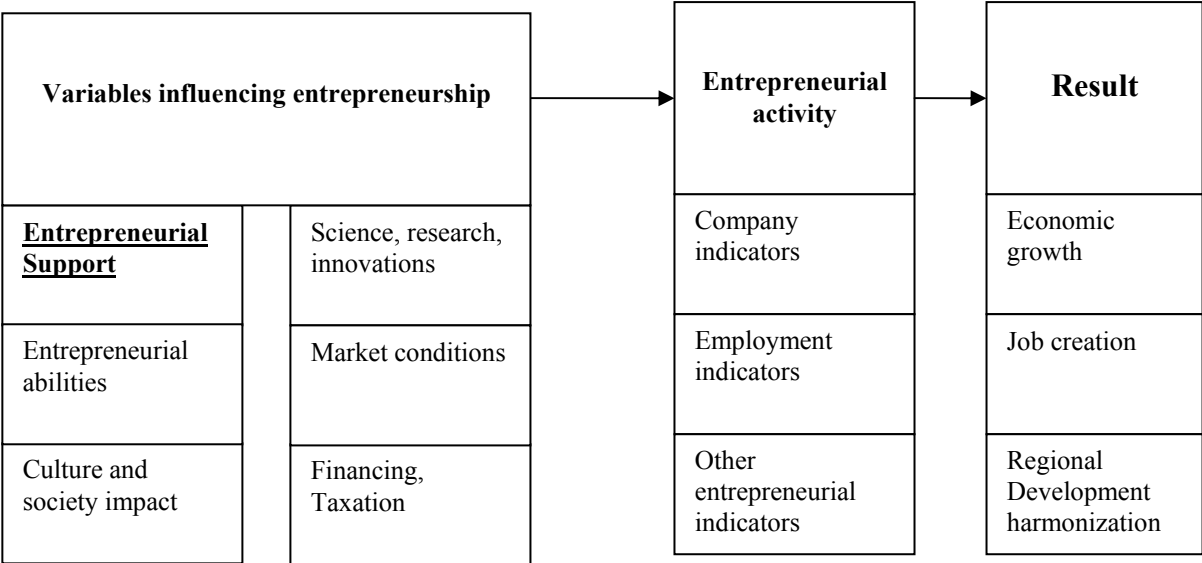

*Source: own*

Concluding we expand on our conceptual model of the underpinnings of entrepreneurship policy (Fig. 4), stressing the complexities involved in trying to determine how to increase the supply of entrepreneurs in an economy given via influencing an individual's propensity to start a business.

**5. Discussion**

We hereby highlight some of the important evaluation issues for the entrepreneurship policy area and, to some extent, the area of SME policy. In fact, we draw heavily from the existing European Union knowledge base in the field of SME policy evaluation. The entrepreneurship policy area has not yet been explored much in the literature. However, the theory applied and methods discussed for the SME policy area are often applicable to the entrepreneurship policy area.

We found evidence that government has set objectives to strengthen the entrepreneurial culture and to increase the level of entrepreneurial activity and business entry rates. [8] It is supporting these objectives as a strategic priority with concrete policy measures and targets. An increasing amount of attention is being paid

to areas of the entrepreneurship policy framework defined in our study, [8] for example, the integration of entrepreneurship in the education system and policies targeted to defined segments of the population, especially women and innovative entrepreneurs. Growing emphasis is being given to entrepreneurship development in regional development strategies with more actions being taken at the regional and local levels. [8]

In other words, entrepreneurship policy is evolving as more of a distinct policy field. There are now programs and policies for this area in almost every developed country, as well as formulations by the Commission of the European Union. Interest in the public policy implications of fostering entrepreneurial activity has also been growing within the research community and the importance of entrepreneurship as a tool for improving the economic and social situations in developing economies has escalated. In spite of these recent developments, many compelling questions and policy dilemmas persist. These relate to the nature of the causal relationship between entrepreneurial activity levels and economic growth, the setting of policy targets, the application of policies in different contexts, management of policy development and implementation processes, and evaluation issues.

To state what can be precisely done to increase the level of entrepreneurial activity within an economy and which framework conditions are the most essential for entrepreneurship and boosted growth we have to confess that there is no straightforward answer. Still there is widespread agreement among the researchers who are working on this problem that there are indicators that are essential to any effective entrepreneurship support policy: business entry and exit dynamics - venture spirit, administrative burden, advisory services, financing, taxation and commercialization of research results. From the scientific point of view there is limited clarity as to which combination of policy measures will produce the desired result. The answer appears to lie somewhere in the complex interplay between dimensions of the individual (the entrepreneur), the enterprise and the environment.

Many policy prescriptions have been done to state what should be done in the entrepreneurial support to produce higher levels of entrepreneurial activity, but limited knowledge exists about how entrepreneurship policy is constructed - what it actually looks like, what policies characterize its make-up and how policymakers make decisions about the mix of these policies. More knowledge about this will be very important for governments to have in light of rapidly changing industrial and economic policy paradigms where entrepreneurship is becoming a recognized force in the attainment of positive economic outcomes.

Implementation of SME and entrepreneurship policies requires an appropriate delivery structure and a commitment of human and budget resources. The investment of public funds is substantial with the potential to affect the economic system in various ways. Therefore, policy and program evaluation issues need to be considered. Issues of evaluating SME policies have been well articulated by Audretsch [2]. International organizations, such as the European Commission, are increasingly emphasizing the importance of proper policy and program evaluation and working with member States and countries to develop more systematic approaches. The

evaluation issues have been much in focus during the recent process of assessing the overall impact of the EU Structural Funds Program.

## **Conclusion**

We find a great deal of important input to our understanding of the factors creating a context model for Entrepreneurial Support in a society. One of our main conclusions is that in making entrepreneurship policy, context certainly matters. We find that it is difficult to find simple correlations between factors influencing entrepreneurship and the level of entrepreneurial activity and, for example, economic growth. Entrepreneurship support policy is an emerging area of economic policy development that is not yet well developed. Government interest in the role of entrepreneurship in economic development and growth begins to intensify, but there is a limited knowledge about entrepreneurship as a policy area or about how strategically design and implement such a policy area. There appears to be a considerable confusion around what constitutes policies to stimulate the development of entrepreneurship versus the traditional and well-entrenched set of policies to promote SMEs. Based on our analysis we hold the view that the set of policies necessary to increase entrepreneurial activity levels are qualitatively and quantitatively different than those that should be implemented to protect and strengthen the SME sector. Although entrepreneurship is emerging as a policy issue, we believed that as a policy domain, it suffers from a lack of clarity and specificity. If entrepreneurship policy is to stand as a distinct policy field, it would need better definition and articulation.

We discovered that measures to stimulate and support the emergence of entrepreneurship support that can be called a „holistic“ entrepreneurship policy approach is the ideal one. But unfortunately Czech policy to support entrepreneurship can be rather called „added-on“ to existing SME policies or, to a lesser degree is incorporated within innovation policy frameworks.

As an outcome of the study we have drafted policy analysis cycle in steps by isolating problems, defining objectives and selecting measures. We have also identified contextual factors that are essential to any effective entrepreneurship support policy, challenges related to the effective design and delivery of entrepreneurship policy that is in need of further examination, including development of appropriate performance indicators and evaluation measures and national and regional level implementation structures.

## **References**

- [1] ACS, Z., CARLSSON, B., KARLSSON, Ch. *The Linkages among Entrepreneurship, SMEs and Macroeconomy*. Cambridge University Press. 1999. ISBN: 0-521-62105-4.
- [2] AUDRETSCH, D. *Entrepreneurship: A Survey of the Literature* prepared for European Commission, enterprise Directorate General. Brussels. July 2010. ISBN: 92-894-4898-9
- [3] DRUCKER, P. *Managing in Turbulent Times*. New York: Harper and Row, 1980. ISBN: 978-80-7261-140-9

- [4] HAYEK, F. A. *Prices as the Results of Human Action, but Not Human Design*. Chicago: The University of Chicago Press, 1967. ISBN: 0-226-26414-9.
- [5] KIRZNER, I. M. *Competition and Entrepreneurship*. Chicago: University of Chicago, 1973. ISBN: 0-226-43776-0.
- [6] KIRZNER, I. M. *Perception, Opportunity, and Profit: Studies in the Theory of Entrepreneurship*. Chicago: University of Chicago, 1979. ISBN: 978-1-84950-516-1.
- [7] LUCAS, R. E. *Models of Business cycles*. Oxford: Blackwell, 1987. ISBN: 0631-147918.
- [8] MANDYSOVÁ, I. *Podpora podnikání v ČR a v EU*. 2009. ISBN: 978-80-7395-220-4.
- [9] MANDYSOVÁ, I. *Teoretická východiska podnikání*. In Scientific Papers of the University of Pardubice – Series D, Faculty of Economics and Administration 13, Univerzita Pardubice, 2008, s. 126 – 131. ISBN: 978-80-7395-149-8.
- [10] PFEFFER, J. *Organizations and organization Theory*. Boston: Pitman, 1982. ISBN: 0273018515.
- [11] SHAPERO, A. *Why Entrepreneurship?*, Journal of Small Business Management 23 (4), 1 – 5, 1985. ISSN: 1540-627X.
- [12] [http://www.czso.cz/csu/2009edicniplan.nsf/publ/01n2-09-za\\_4\\_\\_ctvrtleti\\_2009](http://www.czso.cz/csu/2009edicniplan.nsf/publ/01n2-09-za_4__ctvrtleti_2009)
- [13] [http://ec.europa.eu/enterprise/policies/finance/files/2011\\_safe\\_analytical\\_report\\_en.pdf](http://ec.europa.eu/enterprise/policies/finance/files/2011_safe_analytical_report_en.pdf)
- [14] <http://www.internationalentrepreneurship.com/total-entrepreneurial-activity/>

## Contact Address

### Ivana Mandysova, Ph.D.

University of Pardubice, Faculty of Economics and Administration, Institute of Regional and Security Sciences  
 Studentska 84, 532 10 Pardubice  
 Email: [ivana.mandysova@upce.cz](mailto:ivana.mandysova@upce.cz)  
 Phone number: 46 603 6528\*/

Received: 30. 04. 2012

Reviewed: 26. 07. 2012

Approved for publication: 01. 11. 2012

# DECISION-MAKING ON IPO IMPLEMENTATION UNDER CONDITIONS OF UNCERTAINTY

Tomáš Meluzín, Karel Doubravský, Mirko Dohnal

**Abstract:** *The theory of corporate financing considers the decision-making on the implementation of the IPO as one of the most important decision-making problems in the life-cycle of the undertaking. In addressing this decision-making task, however, are often not known all the necessary information – the likelihood of each condition. In a situation where we know only the fuzzy probabilities of certain states, it is appropriate to use quantitative methods, for example fuzzy linear programming. The aim of the contribution is to show on a case study use of the decision tree for deciding on the implementation of the IPO. Case study is divided into two parts. In the first part are known all the probabilities of each state, in the second part is known the likelihood of only some of the states, moreover, these probabilities are entered quite freely.*

**Keywords:** *IPO, Decision-making, Uncertainty, Water probability, Fuzzy logic.*

**JEL Classification:** *G32, C35.*

## Introduction

The theory of corporate financing is considering the decision on execution or non-execution of IPO<sup>4</sup> for one of the most important decision-making problems during the life cycle of the company. There are offered many attitudes which aim to find a solution to this decision-making situation. The traditional approach is, regardless of the more detailed theoretical explanation, based on preparation of an overview of the possible advantages and drawbacks from implementation of the IPO. Similar reports are usually the result of surveys in enterprises making an IPO, or they reflect the views of the subjects who participate in the IPO. Lists are usually extensive, but not all in them mentioned advantages and disadvantages are necessary as a result of implementation of the IPO. Another possibility is usage of quantitative methods, such as fuzzy linear programming. The aim of the contribution is to show on a case study use of the decision tree for deciding on the implementation of the IPO. Case study is divided into two parts. In the first part are known all the probabilities of each state, in the second part is known the likelihood of only some of the states. It is therefore a task with partial ignorance.

## 1 Statement of a problem

Decision tasks are often represented by single root trees and sets of available III (input information items) probabilities, penalties etc. The full III set is either not available or some of its elements are prohibitively vague under realistic conditions, see e.g. [1]. A methodology / heuristic(s) is therefore needed to quantify the missing set of III.

---

<sup>4</sup> IPO is an abbreviation for „Initial Public Offering“. That is marked by the fact, that the company offers its shares to public for the first time, and at the same time it enters on the public organised stock market, represented the most frequently by the exchange stock as peak institution.

Decision makers who solve tasks are not willing to invest too much time into study of complex formal theories. They require such decisions which can be (re) checked by simple common sense reasoning to eliminate potential mistakes. Real-life decision making analysis must take into consideration the fact that precise information is missing, see e.g. [2]. The mentioned decision making theories have been very rarely studied from the company perspective see e.g. [3].

The following heuristic, see e.g. [4]:

*The longer the path the less probable the path is* (1)

is relatively easily accepted by those who routinely solve real life decision tasks. We strongly believe that there are several reasons for that: the heuristic is simple, based on common sense and its formalisation does not require sophisticated formal tools.

The algorithm studied in this paper is based on a strong analogy between a water flow through a one root tree system of pipes and the decision tree of the same topology. To make the common sense rechecks the following simplifications of the piping system are used:

- Each branch of the decision tree is considered to be a pipe of the same diameter and length. (2)
- All pipes are horizontally situated.

### 1.1 Water probability

Let us suppose that one liter of water is pumped into the root node of the decision tree and there is no accumulation of water in the tree. The consequence is that one liter of water must leave the tree through its terminal nodes. A reinterpretation of the heuristic (1) is:

*The flowrate of water through a node is equal to its probability.* (3)

The following algorithm is based on a simplified linear model to make the interpretation of the results more transparent for general audience.

The heuristic (1) is based on the assumption that the longer a decision (sub) branch is the less.

Let  $A$  be an event, and  $\Omega$  is a set of all possible events, i.e. event space. An event probability  $p(A)$  must satisfy three following axioms [5]:

$$\text{for all } A \in \Omega, p(A) \geq 0, \quad (4)$$

$$p(\Omega) = 1, \quad (5)$$

$$p(A_1 \cup A_2 \cup \dots \cup A_i) = \sum_i p(A_i), \quad (6)$$

where  $A_i$  is a set of disjunctive events. The relevant water flow through the node  $N$  satisfies the axioms (4, 5, 6), see [4].

## 1.2 Topological resistance

A decision tree has one root node  $R$ , see e.g. Fig. 1:

**Fig. 1: A Decision Tree**

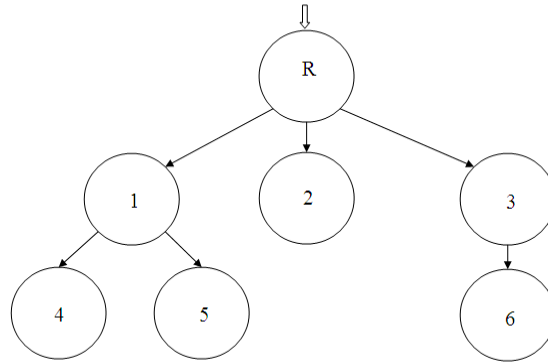

*Source: own processing*

The following definitions are used:

$T$  be a set of terminals, see nodes 4, 5 and 6, Fig. 1.

$N$  be a set of all nodes.

$w_i$  is a number of ingoing and outgoing edges of  $i$ th node.

$s_i$  is a number of edges of the subtree where  $i$  is the subroot.

$$s_i = \sum_j w_j . \quad (7)$$

where  $j$  represents nearest nodes of the subtree behind  $i$ th node.  $a_{i,j}$  is a water/probability splitting ratio form  $i$ th node to  $j$ th node:

$$a_{i,j} = \frac{w_j}{s_i} , \text{ for all } j \in N - T . \quad (8)$$

$K$  is a cardinality of  $N$ , the number of nodes.  $P_j$  of  $j$ th terminal for  $j \in N$  is a flowrate of water through  $j$ th node. The value  $P_R$  of a root node is always equal one.

$$P_R = 1 . \quad (9)$$

For other nodes can be calculated by following (balance) equations

$$P_j = \sum_{i=1}^k (P_i \cdot a_{i,j}) , j = 1, 2, \dots, K . \quad (10)$$

The set of  $K$  linear equations (10) where the set  $P$  is a vector of unknown variables and the splitting ratios  $a$  (8) are numerical constants can be easily solved.

*Example* The heuristic (3) can be used for evaluation of resistances (7), see Fig. 1:

( $i$ th node)	Subtree	$w_i$	$s_i$
1	R $\rightarrow$ 1 $\rightarrow$ 4 $\rightarrow$ 5	3	2
2	R $\rightarrow$ 2	1	-(Node 2 is a terminal)
3	R $\rightarrow$ 3 $\rightarrow$ 6	2	1
4	1 $\rightarrow$ 4	1	-
5	1 $\rightarrow$ 5	1	-
6	3 $\rightarrow$ 6	1	-

(11)

Where symbol “-” in fourth column indicates the  $i$ th node is a terminal.  
The following splitting ratios (8) are:

$$\begin{aligned}
 a_{r,1} &= 1/6 = 0.167, \quad a_{r,2} = 3/6 = 0.5, \quad a_{r,3} = 2/6 = 0.333, \\
 a_{r,1} + a_{r,2} + a_{r,3} &= 1, \\
 a_{1,4} &= 1/2 = 0.5, \quad a_{1,5} = 1/2 = 0.5, \\
 a_{1,4} + a_{1,5} &= 1, \\
 a_{3,6} &= 1.
 \end{aligned}$$

(12)

The system of linear equations (9, 10) is as follows, see Fig. 1:

$$\begin{aligned}
 1 + 0 \cdot P_1 + 0 \cdot P_2 + 0 \cdot P_3 + 0 \cdot P_4 + 0 \cdot P_5 + 0 \cdot P_6 &= P_R, \\
 0.167 \cdot P_R &= P_1, \\
 0.500 \cdot P_R &= P_2, \\
 0.333 \cdot P_R &= P_3, \\
 0.500 \cdot P_1 &= P_4, \\
 0.500 \cdot P_1 &= P_5, \\
 1 \cdot P_3 &= P_6.
 \end{aligned}$$

(13)

Solving system of equations (13) gives the probabilities of the terminal hypothesis.

### 1.3 Partial ignorance

A typical feature of all realistic decision tasks is a shortage of information. Isolated information items, e.g. probabilities of certain events are known. The concept of the total ignorance represented by e.g. the meta heuristic (1) helps to incorporate a set of isolated specific information items within a general framework of metaheuristics.



An incomplete set of probabilities

$$R \equiv (R_1, R_2, \dots, R_h) \quad (14)$$

has  $h$  elements. However, the set  $R$  is not complete and therefore it is not possible to use well known algorithms of quantitative decision making.

For example the probability of node 2, see Fig. 1 is *small*. And this is the only known / given quantitative value:

$$R_2 = \textit{small}. \quad (15)$$

It means that  $h = 2$ , see (14). The quantification is verbal. It is possible to discover if the additional quantitative items  $R$  (14) are consistent with the heuristic (1).

If the differences

$$|R_i - P_i|, i = 1, 2, \dots, N \quad (16)$$

are too significant, and this is nearly always the case, a reconciliation is inevitable.

#### 1.4 Reconciliation

There are different reconciliation procedures. The problems of reconciliation are very important and have been studied for more than 30 years [6].

A very flexible and productive idea is a fuzzy interpretation of the numerical values of the set (14):

$$P = R_i, \quad (17)$$

where  $R_i$  is the fuzzy set which is given as a part of the problem specification. The over specified set of fuzzy set of linear equation is (10, 17):

$$\mathbf{A} \cdot \mathbf{P} = \mathbf{B} \cup \mathbf{P} = \mathbf{R}, \quad (18)$$

has  $n + h$  equations and  $n$  variables  $\mathbf{P}$  (see (14)). The reconciliation can be solved by a fuzzy linear programming, see e.g. [7, 8].

#### 1.5 Fuzzy reconciliation

The set of equations (17) is over specified. Different equations are differently reliable. Rather often certain equations cannot be violated at all. For example probability of a terminal event, see e.g. node 4 in Fig. 1, is known very accurately. Therefore the corresponding additional probability  $\mathbf{P}$  must be reconciliation algorithm which takes into consideration different violation of different equations (18).

A simple example is used to demonstrate the basic idea of fuzzy reconciliation. However, A level /extent of violation is specified by a fuzzy interpretation of the set  $R_i$ . Our

experience indicates that the fuzzy set  $R_i$  is mean fully characterised by triangular grades of memberships, see e.g. Fig. 3

$$a \quad b = c \quad d. \quad (19)$$

$$\mathbf{P} = \mathbf{R}. \quad (20)$$

The vector of right hand side coefficients  $R_P$  is quantified using fuzzy numbers [9]. To simplify the problem let us suppose that the triangular numbers are used (19).

The  $j$ -th equation (20) can be transformed into four linear inequalities [10] by introducing two slack variables  $S_{uj}$  and  $S_{lj}$ .

$$\sum_{i=1}^h (a_{ji} \cdot P_i) + S_{uj} \geq b_j, \quad (21)$$

$$\sum_{i=1}^h (a_{ji} \cdot P_i) - S_{lj} \leq b_j, \quad (22)$$

$$0 \leq S_{uj} \leq b_j - a_j, \quad (23)$$

$$0 \leq S_{lj} \leq d_j - b_j, \quad (24)$$

where

$b_j, a_j, d_j$  - see (19),

$S_{uj}$  - is the  $j$ -th upper slack variable,

$S_{lj}$  - is the  $j$ -th lower slack variable.

The set of inequalities (21–24) represents fuzzy description of  $j$ -th linear equation (10).

The total ignorance is always dangerous. The more the system of linear equations is over specified the better. The set of additional information (15) allows us to cross check not only the metaheuristics but the additional information items as well. The following simple requirements must be satisfied

$$m < h. \quad (25)$$

One possible objective function which represents a meaningful trade-off is

$$Q = \min_{S_u, S_l} \left[ \sum_{j=1}^m (S_{uj} / (b_j - a_j) + S_{lj} / (d_j - b_j)) \right]. \quad (26)$$

It is possible to transfer the minimisation problem (26) to a fuzzy linear programming problem and this problem can be finally solved as a conventional linear programming task, see e.g. [11, 12].

For example the probability of node 2, see e.g. Fig. 1, is defined as ‘*small*’. This verbal ‘*small*’ can be expressed by a fuzzy set (19)

$$a = 0.1; b = c = 0.2; d = 0.25. \quad (27)$$

The equation  $R_2 = (0.1; 0.2; 0.25)$  (e.g. balance) can be transformed by (21–24) into four linear inequalities by introducing two slack variables  $S_u$  and  $S_l$ .

$$\begin{aligned}
 0.1 \cdot P_2 + S_u &\geq 0.2, \\
 0.1 \cdot P_2 - S_l &\leq 0.2, \\
 0 \leq S_u &\leq 0.1, \\
 0 \leq S_l &\leq 0.05.
 \end{aligned} \tag{28}$$

The inequalities (28) are added to the balance equations (13). This system of linear equations is supplemented by one possible objective function (29) and it is solved using linear programming methods.

$$Q = \min_{S_u, S_l} [S_u / 0.1 + S_l / 0.05]. \tag{29}$$

## 2 Methods

To achieve the stated objectives have been first selected three factors, which we consider to be a key for the decision-making on implementation of the IPO. Further we were considering about two situations. In the first one are known all the necessary information for decision-making, in the second are known fuzzy likelihood of only certain conditions. The first situation required a solution by normally used method of the decision-making tree. The second solution consisted in finding missing probabilities by use of the water heuristic, adding the specified fuzzy probabilities and solving of this problem using linear programming.

## 3 Problem solving

For the sake of keeping the scope of this article within acceptable limits there was selected a medium-sized decision-making tree. This decision-making tree addresses the entry of the company on the Stock Exchange through IPO. When you build the decision-making tree there have been taken into account the following factors:

- macro-economic growth (increments of GDP),
- Investor's interest in the IPO,
- size of the issue (number of issued shares multiplied by their emission rate).

We consider these factors to be key for the decision-making on the implementation of the IPO, it is, however, only a selection from many others, which affect the success of the IPO. Modified version of this decision-making tree is seen on figure 3. In the decision-making tree are used two types of nodes: situations (rings) and decision-making (squares and boxes). The rings represent the "Lottery", where the decision-maker is not able to influence the future state (the state is decided by neighbourhood of the decision-maker). The squares represent decisions which are within the competence of decision-maker. Boxes represent the end nodes.

Case study is divided in two parts. In the first part are known all the probabilities of each state, in the second part are known fuzzy probabilities of only some of the states (partial ignorance).

**Fig. 2: Decision-making tree IPO**

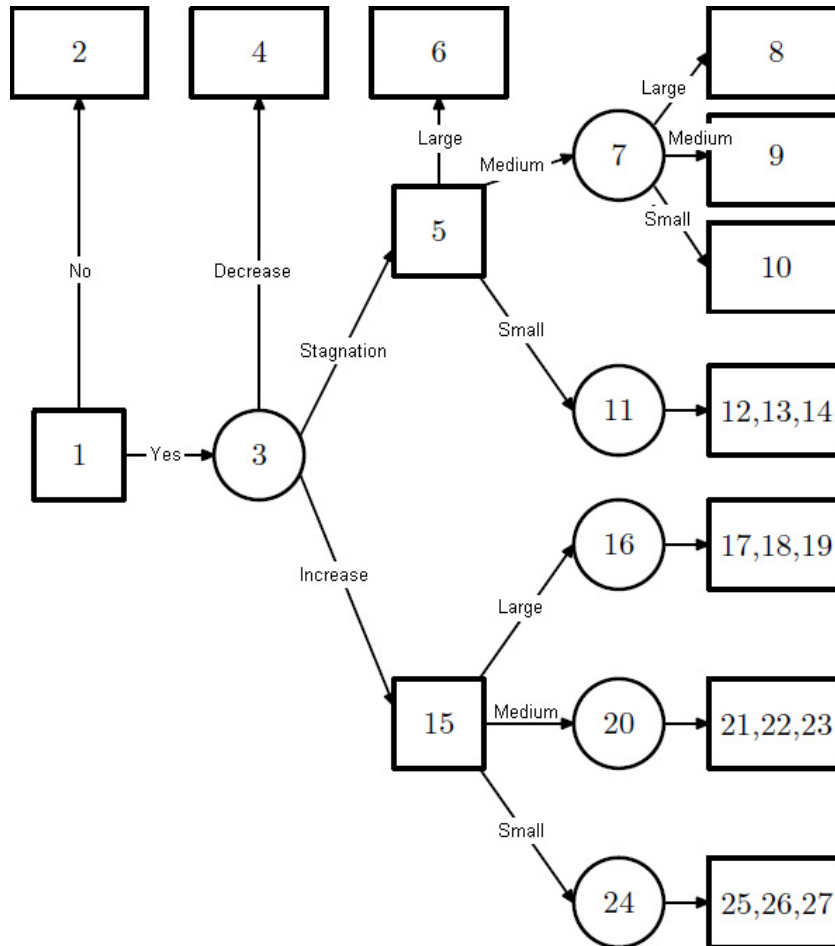

Source: own processing

From the figure 2 it is apparent that in the framework of the space savings are the individual boxes 12-14, 17-19, 21-23, 25-27 unified into one. In fact, they are handled as three separated rectangles (as well as with the rectangles 8-10). In the following table is described the importance of the main knots of the chart.

**Tab. 4: Importance of knots**

The Knot no.	Meaning	The Knot no.	Meaning
1	Implement the IPO?	15	Size of the IPO
2	STOP	16	Investor's interest
3	GDP	20.	Investor's interest
4	STOP	24	Investor's interest
5	Size of the IPO		
6	STOP		
7	Investor's interest		
11	Investor's interest		

Source: own processing

### 3.1 Problem solving in case of knowledge of probabilities of all conditions

The following table shows the profits of the individual variants of the decision and the relevant known probabilities.

**Tab. 5: Profit and the specified probabilities**

Variant	Probability of the variant	Profit (mil. CZK)	Variant	Probability of the variant	Profit (mil. CZK)
3-4	0.15	0	16-17	0.50	100
3-5	0.30		16-18	0.30	50
3-6	0.55		16-19	0.20	10
7-8	0.20	30	20-21	0.30	40
7-9	0.50	10	20-22	0.50	20
7-10	0.30	-5	20-23	0.20	0
11-12	0.10	10	24-25	0.20	30
11-13	0.50	-5	24-26	0.50	20
11-14	0.40	-20	24-27	0.30	-10

*Source: own processing*

On the basis of these data were calculated average profits for individual variants (tab. 3).

**Tab. 6: Average of the profit**

Variant	5-7	5-11	15-16	15-20	15-24	1-3	1-2
Average profit (mil. CZK)	9.5	-9.5	67	22	13	34.7	0

*Source: own processing*

#### Evaluation:

From these calculations is obvious that in the present case, it is recommended:

- 1) Implement the IPO in case of stagnation, or of GDP growth,
- 2) in case of stagnation of GDP choose middle issue, in the case of GDP growth choose a big issue,
- 3) largest profit will be achieved in the case of great interest of investors in both variants.

Average value of profit is CZK 34.7 mil.

### 3.2 Problem solving in case of fuzzy knowledge of only certain conditions

In the following section is described the case of the decision tree, where are known only some probabilities. The following table shows the profits of the individual variants of the decision and the relevant entered probabilities.

**Tab. 7: Profit and the specified probabilities**

Variant	Probability of the variant	Profit (mil. CZK)	Variant	Probability of the variant	Profit (mil. CZK)
3–4		0	16–17	about 0.05	100
3–5			16–18		50
3–6			16–19	about 0.80	10
7–8		30	20–21	about 0.90	40
7–9	about 0.20	10	20–22		20
7–10	about 0.70	–5	20–23		0
11–12		10	24–25		30
11–13		–5	24–26		20
11–14		–20	24–27		–10

Source: own processing

From the table is obvious, that there are known only the probabilities of some variants. In addition, these probabilities are entered very freely. It is thus a partial ignorance task which is described in the previous chapter. In the calculation of the remaining probabilities is used metaheuristics (3). Freely entered probabilities can be for further calculations converted to fuzzy values. The transcription may be executed with a transcript to a triangular fuzzy number (see fig. 3).

**Fig. 3: Triangular fuzzy number**

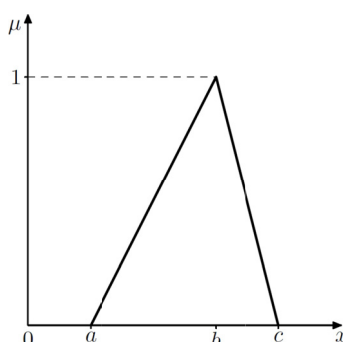

Source: own processing

Numeric conversion is seen in the following table.

**Tab. 8: Conversion of probabilities to fuzzy**

	a	b	c
$a_{7,9} =$	0.1	0.2	0.3
$a_{7,10} =$	0.6	0.7	0.85
$a_{16,17} =$	0.03	0.05	0.07
$a_{16,19} =$	0.7	0.8	0.85
$a_{20,21} =$	0.8	0.9	0.95

Source: own processing

The remaining probabilities are calculated on the basis of topological resistance (7), balancing equations (10) and the partial ignorance (15) – see the following table.

**Tab. 9: The dividing ratios**

Variant	Probability of	Variant	Probability of
3-4	0.542	16-17	0.050
3-5	0.417	16-18	0.200
3-6	0.042	16-19	0.750
7-8	0.100	20-21	0.900
7-9	0.200	20-22	0.100
7-10	0.700	20-23	0.000
11-12	0.333	24-25	0.333
11-13	0.333	24-26	0.333
11-14	0.333	24-27	0.333

Source: own processing

On the basis of these data were calculated average profits for individual variants (tab. 7).

**Tab. 10: Average profit**

Variant	5-7	5-11	15-16	15-20	15-24	1-3	1-2
Average profit (mil. CZK)	1.5	-4.995	22.5	38	13.32	-2.79	0

Source: own processing

### Evaluation:

In the present case, it is recommended not to realise the IPO, since the mean value of the profit results at CZK -2.79 mil.

### Conclusion

The theory of corporate financing considers the decision-making on the implementation of the IPO as one of the most important decision-making problems in the life-cycle of the undertaking. In addressing this decision-making task, however, are often not known all the necessary information – the likelihood of each condition. In a situation where we know only the probability of certain states, and where these probabilities are entered freely, it is appropriate to use quantitative methods, for example fuzzy linear programming. In this method, it is first necessary to specify the probabilities for single conditions by using a water metaheuristics. This heuristic is based on the principle of water flow through a piping where individual separating conditions in the monitored nodes correspond to the searched probabilities. On the basis of established separating ratios (probabilities) is created with support of balance equations a system of linear equations. To these equations are then added the linear equations, based on the entered fuzzy probabilities. Thus created system of the equations is further supplemented by a specific function. In this function we are trying to minimize the deviation of the found probabilities from the given fuzzy probabilities. The advantage of this approach lies in the fact that the specific function and the equations of the individual restrictions are linear, and therefore easily solvable using commonly known simplex method. In addition, this method is also applicable in other fields where it is needed to make decisions under conditions of uncertainty.

## References

- [1] APOSTOLAKIS, G., LEE, Y. T. Methods for the estimation of confidence bounds for the top-event unavailability of decision trees. *In Nuclear Engineering and Design*, 1997, Vol. 41, Iss. 3, pp. 411–419. ISSN: 0029-5493.
- [2] DANIELSON, M., EKENBERG, L., LARSSON, A. Distribution of expected utility in decision trees. *In International Journal of Approximate Reasoning*, 2007, Vol. 46, Iss. 2, pp. 387–407. ISSN: 0888-613X.
- [3] NIE, G., ZHANG, L., LIU, Y., et al. Decision analysis of data mining project based on Bayesian risk. *In Expert Systems with Applications*, 2009, Vol. 36, Iss. 3, pp. 4589–4594. ISSN: 0957-4174.
- [4] DOHNAL, M., VYKYDAL, J., KVAPILIK, M., et al. Practical uncertainty assessment of reasoning paths (fault trees) under total uncertainty ignorance. *In International Journal of Loss Prevention*, 1992, Vol. 5, Iss. 2, pp. 125–131. ISSN: 0950-4230.
- [5] DOHNAL, M. Ignorance and uncertainty in Reliability Reasoning. *Microelectronics and Reliability*, 1992, Vol. 32, Iss. 8, pp. 1157–1170. ISSN: 0026-2714.
- [6] WATSON, S. R. The meaning of probability in probabilistic safety analysis. *Reliability Engineering and System Safety*, 1994, Vol. 45, Iss. 3, pp. 261–269. ISSN: 0951-8320.
- [7] FEDRIZZI, M., KACPRZYK, J., VERDEGAY, J.L. A survey of fuzzy optimization and mathematical programming. In FEDRIZZI, M., KACPRZYK, J., ROUBENS, M., eds. *In Interactive Fuzzy Optimization*. Berlin: Springer-Verlag, 1991, p. 15–28. Lecture Notes in Economics and Mathematical Systems. Vol. 368. ISBN: 9780387545776.
- [8] LAI, Y.J., HWANG, C.I. *Fuzzy Mathematical Programming: Methods and Applications*. Berlin: Springer-Verlag, 1992. Lecture Notes in Economics and Mathematical Systems. Vol. 394. ISBN: 354056098X.
- [9] KIKUCHI, S. A. Method To Defuzzify The Fuzzy Number: Transportation Problem Application. In *Fuzzy Sets And Systems*, 2000, Vol. 116, Iss.1, pp. 3- 9. ISSN: 0165-0114.
- [10] RAYMOND, R. T., BRIONES, L.M.A., CULABA, A.B. Fuzzy data reconciliation in reacting and non-reacting process data for life cycle inventory analysis. *In Journal of Cleaner Production*, 2007, Vol. 15, Iss. 10, 2007, pp. 944-949 [cit. 2012-24-01]. ISSN 0959-6526. Available at WWW: doi:10.1016/j.jclepro.2005.09.001



- [11] GUOHE, H., MOORE, R.D. Grey linear programming, its solving approach, and its application. *In International Journal of Systems Science*, 1993, Vol. 24, Iss. 1, pp.159 – 172. ISSN: 0020-7721.
- [12] BUCKLEY, J. Possibilistic linear programming with triangular fuzzy numbers. *In Fuzzy sets and systems*, 1988, Vol. 26, Iss. 1, pp.135-138. ISSN: 0165-0114.

### Contact Address

**doc. Ing. Tomáš Meluzín, Ph.D.**

**Ing. Karel Doubravský, Ph.D.**

**prof. Ing. Mirko Dohnal, DrSc.**

Brno University of Technology, Faculty of Business and Management, Department of Economics

Kolejní 2906/4, 612 00 Brno, Česká republika

E-mail: meluzint@fbm.vutbr.cz

Tel.: +420 541 143 728

Received: 26. 01. 2012

Reviewed: 15. 06. 2012

Approved for publication: 01. 11. 2012

# HUMAN RESOURCE MANAGEMENT UNDER CHANGES AT FOREIGN SUBSIDIARIES IN SLOVAKIA IN LIGHT OF REGIONAL COMPARISON

József Poór, Martin Vološin, Allen Engle, Renáta Machová,  
Mártonné Karoliny

**Abstract:** *A model of human resource management practices in the subsidiaries of multinational corporations in Slovakia was developed by the Central and Eastern European International Research Team (hereafter CEEIRT) – composed of researchers from universities from the Central and Eastern European Region. This model describes the changes of key HR variables in the light of different firm specific factors. Based on this model, an interview and on-line survey of top level HR executives at 22 subsidiaries of large multinational companies in Slovakia and at 267 foreign owned firms in other CEE countries was completed. The paper describes how these practices and roles have developed in response to the sweeping economic changes within the region and points out the expectations of practitioners for the future. Initially our article focuses on the analysis of previous relevant HR results and models. Next way we present an overview of Foreign Direct Investment (FDI) development in new member states of the European Union, particularly in Slovakia. Besides the analysis of the FDI origin country the sectoral structure of FDI and employment practices in foreign firms on the Slovak territory is analyzed.*

**Key words:** *Human resource management, Foreign direct investment (FDI), Local subsidiaries and Central and Eastern Europe (CEE).*

**JEL Classification:** *M12, O15.*

## Introduction

According to the UNCTAD World Investment Report 2010, global foreign direct investment (FDI) witnessed a modest, but uneven recovery in the first half of 2010. This sparks some cautious optimism for FDI prospects in the short run and for a full recovery further on. UNCTAD expects global inflows to reach more than \$1.2 trillion in 2010, rise further to \$1.3–1.5 trillion in 2011, and head towards \$1.6–2 trillion in 2012. However, these FDI prospects are fraught with risks and uncertainties, including the fragility of the global economic recovery.

## 1 Statement of a problem

### 1.1 FDI globally and in CEE region and in Slovakia

Developing and transition economies attracted half of global FDI inflows, and invested one quarter of global FDI outflows. They are leading the FDI recovery and will remain favourable destinations for FDI.

According to the Slovak Statistical Office data, about 650 billion US dollars of foreign investment flowed into the twelve new EU member countries until 2009. From this investment Slovakia obtained 50.1 billion USD and had a share of 7.7%. Hungary obtained 85.9 billion (share of 13.2%), Poland 182.8 billion USD and Czech Republic 115.8 billion USD [13], [19].

## 1.2 Employment and foreign capital

Foreign direct investment was very important for economic development, employment and economic growth of Central European countries on their way to the market economy. Especially Slovakia, which is the smallest economy among the Visegrad four countries (Czech Republic, Hungary, Poland and Slovakia), recorded in several past years very rapid economic growth thanks its economic reform and relatively high level of FDI inflow. This growth had a positive impact on the rate of unemployment, but it is still a problem which has various reasons: In Slovakia there is still high rate of unemployment of certain socially weak groups of population, investment is not evenly spread in the country and economic recovery after the crisis is still rather slow.

From a global point of view, international companies employ more than 80 million people in their subsidiaries all over the world [12], [16], [17]. The proportion of people employed at subsidiaries of international companies varies significantly between countries. According to the representative data of the UNCTAD World Investment Report, 50,6% of the employees in the private sector work for multinational companies in Ireland. The same indicator in Hungary was 22,4% at the beginning of the millennium, according to the mentioned report.

In Slovakia, foreign-owned companies employed about 600 thousand people in 2010. This number equals to one fourth of the people employed in the Slovak national economy and about 35% of the people employed in the competitive sector

## 2 Methods

In undertaking a study of HR practices in the subsidiaries of MNCs in Central Europe, and specifically in Slovakia, we begin by adopting a broad framework encompassing the major internal factors (objectives of the firm, corporate strategy, firm (subsidiary) maturity, entrance, development for MNC subsidiaries in Slovakia and Central and Eastern Europe (DSS), subsidiary mandates) that affect the operations of such firms (Exhibit 1). While a discussion concerning each element in this model is beyond the scope of this paper, this model provides a context for the discussion, consistent with recent presentations highlighting the criticality of HR variables in the context of situational variables [2], [18].

Based on the elements of the general research model discussed earlier, in this research report we have focused our investigation on the following six key categories:

- *Characteristics of surveyed subsidiaries*: capturing the most important organizational and economic characteristics, namely origin of parent company, year of establishment of subsidiary, main area of operation of the company – sector –, size of organization (based on revenue and number of employees) and

evolution of its productivity ratio, its mandate in value chain and main steps, directions of its development.

- *Key indicators of HR function*: namely number and workload of staff employed in HR departments, main indicators representing importance, results, and efficiency characteristics of HR activity (labour cost – total cost ratio, age distribution of employees, relative weight of training budget, level and rate of fluctuation and absenteeism.)
- *Most important HR characteristics of the period examined*: importance of HR function, use of foreign and Hungarian expats, distribution of roles between central and local HR, role of local HR in developing and operating different HRM subsystems, most important key competencies and fundamental sources of professional development of the person interviewed.
- *Knowledge management of HR*: main directions, methods and characteristics of knowledge flows.
- *The future of HR*: most significant issues or actions in HR expected to occur in the next 12-24 months.
- *Data of respondents*: data on current HR department and its employees. (Comments: Here we will not discuss only the following subject areas: knowledge management in HR and the future of HR).

Most of our questions were related to the characteristics of participating subsidiaries observed in 2009. In some cases (number of staff, revenue and HR efficiency indicators) we collected data both from 2008 and 2009. Although the analysis was descriptive, it revealed objective data in all cases. In order to facilitate statistical analysis, we used the same questionnaire during personal interviews at companies and during online surveying; we coded gathered data and analyzed coded answers.

**Fig. 1: Model and HR Variables Within the Context of Multinational Subsidiaries**

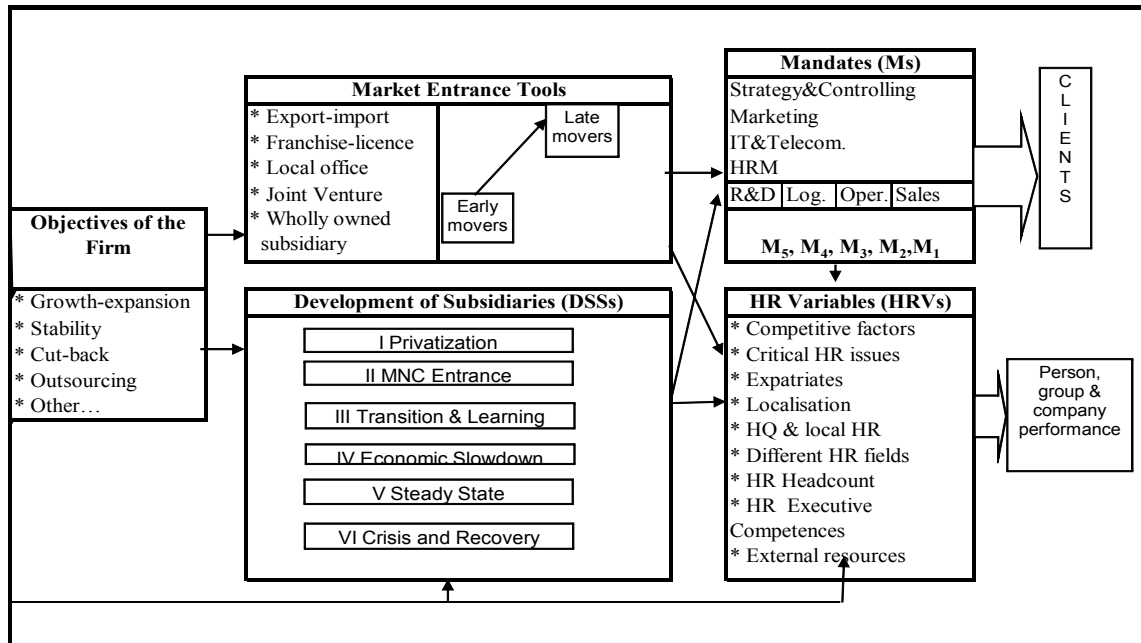

Source: Author

### 3 Population characteristics and the sample

#### 3.1 General characteristics of participating companies

Originally 12 countries indicated their interest to be involved with this project. Ultimately we received valuable information from all 12 countries. These 12 countries have contributed to the regional data set while to date the results from seven countries (Croatia, Estonia, Hungary, Poland, Romania, Serbia and Slovakia) have been prepared for this detailed report.

**Tab. 1: Overview on respondents**

No	Countries	Responses
1	Austria	3
2	Bulgaria	5
3	Croatia	11
4	Czech Rep.	1
5	Estonia	45
6	Hungary	74
7	Lithuania	2
8	Poland	88
9	Romania	17
10	Serbia	20
11	Slovakia	22
12	Slovenia	1
Total		289

Source: Author

In this summary we give an overview of the general characteristics of participating companies, gained in the 22 MNC Slovakian subsidiaries in light of regional comparison (Exhibit 2):

- Some of 289 local subsidiaries of different foreign owned companies registered in the CEE region participated in the survey and 22 from this cohort are responded our survey questionnaire from Slovakia
- The number of staff employed at the companies examined decreased less than we expected due to the crisis. This can be explained by the following points:
  - ↳ Some companies participating in the survey had rationalized their labor force significantly already before the crisis.
  - ↳ Those subsidiaries that employed a significant number of people with fixed-term contracts or leased labor force dismissed these employees in the first place.
  - ↳ Some over diversified companies sold or outsourced their non-core businesses.
  - ↳ The number of employees didn't decrease, moreover increased even during the crisis in many processing and developer companies.

**Tab. 2: Number of employees and revenue of the participating companies in CEE region (n=289) and in Slovakia (n=22)**

Year	CEE		Slovakia	
	Number of employees	Revenue (billion euro)	Number of employees	Revenue (billion euro)
2009	292.697	43,25	20.487	1.049

*Source: Author*

- Some 44% of the organizations examined in the total CEE sample were engaged in manufacturing. And 44% of organizations in trade, tangible and intangible services while 12% of organizations in other industries. In Slovakian sample 39% of the organizations examined were competing in the manufacturing sector, while the other 61% in trade, tangible and intangible services.
- In the CEE sample, the foreign owners of more than half (69%) of the subsidiaries examined acquired majority control or carried out the green-field investments before 1995. The half of the examined subsidiaries came to

Slovakia between 2000 and 2009. More than a third of them (36%) acquired majority control or carried out the Greenfield investments before 1995, the remaining ones (14%) settled in Slovakia between 1996 and 2000.

- Half (50%) of the respondents indicated that they were seeking growth and market expansion during the period examined. Stability, efficiency improvement and revenue retention were also important for more than a half (55%) of the subsidiaries. Only a quarter (27%) of the organizations chose the redundancies and rationalization option, as a description of the main strategic orientation of the years investigated.
- Parent firms in the CEE sample were found from a wide variety of nations in the regional sample. While 60% of the multinational firms came from the following seven countries: Germany (19%), USA (13%), Sweden (6%), France (6.6%), Austria (5.7%), and Hungary and Finland (5.4% each), another 13 countries account for an additional nearly 27% of the sample, and the remaining 13% of the sample is accounted for by 15 countries. The Swedish and Finnish companies are more dominant investors in Northern-Eastern European countries (for instances Estonia and Poland), while the German, Austrian and U.S. companies have a stronger presence in the Central and Southern European countries. More than two thirds (68%) of the participants come from the following countries in Slovakian sample: Czech Republic (27%), Germany (14%), Sweden (9%), USA (9%), and Hungary (9%), while another 7 countries account for the remaining 32%.
- In the CEE sample, the foreign owners of more than half (69%) of the subsidiaries examined acquired majority control or carried out the green-field investments before 1995. The foreign owners of more than half of the companies participating in the survey came to Slovakia realizing green-field investments and 45% of them obtained majority control in Slovakian companies during the privatization and the following acquisitions.
- 43% of the companies operate with a single to develop and market product services for global markets in the CEE sample. Based on the responses it can be stated that almost 40% of the subsidiaries sales its products on the local markets. More than one quarter (27%) of the participants has control just on a part of the value chain but almost one third (32%) controls most of the processes of the value chain.

### **3.2 General characteristics of the responding individuals**

From the personal characteristics of the interviewed professionals we examined demographic characteristics and also their professional qualifications and the characteristics of their positions held.

- Almost half (42%) of the individuals participating in the survey in the total sample are top HR managers: with the title of HR vice president, director, manager or department head.

- In the Slovak survey, one fifth of the respondents' participants are in the top HR manager position and another 45% are in HR or other managerial position. The remaining part of the respondents is member of HR staff or work in other department of the companies examined in the survey.

#### 4 Characteristics of the key indicators of HR function

In this section we give a summary of the following HR characteristics:

- Number and workload of the HR staff,
- The main indicators representing the importance, results, and efficiency characteristics of the HR activity (labor cost – total cost ratio, age distribution of employees, and relative size of the training budget, the fluctuation rate and absenteeism).

##### 4.1 Number and workload of HR staff

In the CEE sample, number of HR staff is relatively high. Only of 4% of responding subsidiaries has not any HR staff. The HR departments of the companies in the Slovakian sample examined are relatively small as the number of HR staff was under than 5 persons in the case of more than 65% of the respondents, while there hasn't been any organization among the subsidiaries which hasn't got any HR staff.

In the CEE sample, employees per HR position ranged between 50 and 147 people in our sample. In comparison with the CEE sample, the majority of the participant organizations in Slovakia employ less than 250 employees. Although the number of the smaller companies increased in the last two years one third of the respondents belong to what we would classify large enterprises. The surveys indicated average number of employees served by one HR staff member increased from 152 in 2008 to 161 in 2009. In these companies nearly 60 % of the total number of HR staff carried out administrative tasks while 40 % were HR professionals.

**Tab. 3: Number of employees and HR staff in the participating companies**

	Number of employees	HR professional	HR admin staff	Total number of HR staff	Employees per HR position
CEE	292.697	1.979	2.662	4.605	64
Slovakia	20.487	59	76	135	161

*Source: Author*



## **4.2 Labour cost – operating cost ratio**

The labor cost – operating cost ratio - is one of the frequently analyzed indicators of the importance of the HR function in the company's life. According to assumptions, the effects of HRM have a stronger and more direct influence on the company's performance if this ratio is higher [2], [5]. In the CEE sample, the vast majority of the companies operated with a relatively low (under 30%) labor cost ratio

About one third of the Slovakian subsidiaries participating in the survey fell into this category (where the labor cost ratio is higher than 40%). But the vast majority (63%) of the companies operated with a relatively low (under 30%) labor cost ratio.

## **4.3 Age distribution**

One of the results of human resource management actions is the age distribution of the labour force. The results of our survey in this respect confirm the common view that multinational companies prefer to employ the younger generations:

- 20% of employees are above the age of 45 in the CEE sample
- the majority (84%) of employees are under the age of 45 in the Slovakian sample.

## **4.4 Training cost ratio**

Literature considers the relative weight of the training budget (compared to the total annual labour cost) as an important indicator of modern and effective HR activity.

- CEE: Some 73% of the companies spent less than 3% of the annual personnel cost budget on training of their employees in 2009.
- Slovakia: In the half of the companies examined, the relative weight of the training budget was under 2% in 2008. We also found a quite high proportion where the companies spent 10-20% or even more of the annual labour budget on training employees. In 2009 the companies with higher rates decreased this number. The global average of this indicator calculated using the Cranet international comparative HR database was 3,36 %, the Eastern European index was 3,15% and the Hungarian 3,54% [8].

## **4.5 Labour turnover**

An important characteristic of HR effectiveness is the labour turnover. According to the conservative approach, the cost of an average employee leaving amounts to 1.5 times their annual wage cost [3]. However, it is important to see that different people's leaving have different consequences. If a key employee leaves the company, it has a much larger impact compared to a simple employee leaving.

- CEE: The level of fluctuation was under 10% in more than half of the subsidiaries; however there are companies with indices higher than 20% or even 40%.
- Slovakia: In 2008 the level of turnover was fairly high in the majority of the subsidiaries participating in the survey. One third of them have 20-30% and two

of them had over 40 %. In 2009 the extreme values haven't changed but the average value of the turnover decreased.

#### **4.6 Expatriates and their roles**

The belief that management practices are universal has spread widely along with globalization. Following Perlmutter's [13] analysis, multinational companies can follow an ethnocentric, polycentric, regiocentric or geocentric selection mechanism. In ethnocentric orientation, key positions of local company are held by professionals from parent company. In polycentric companies, local key positions are held by locals but their promotion to higher positions is very limited. In companies following regiocentric selection mechanism, locals can hold key positions not only in subsidiary but also in centers and in work roles coordinating the management of the region. In companies following geocentric selection mechanism, locals can obtain position even in top management of the company.

Usually two types of long-term expatriate assignments are distinguished. Expatriates arriving from abroad (from parent company of a third country) are also called expatriates, as are employees from the Slovakian subsidiary appointed for a long-term deputation away from Slovakia (at parent company or subsidiaries operating in other countries).

##### ***Foreign expatriates***

Number of expatriates decreases according to level of maturity of subsidiaries. Expatriate managers are most frequently seen during an acquisition or major realignments of a subsidiary's activities. During global crisis there are thought to be fewer expatriates, as they are an expensive form of human resource.

- **CEE:** Nearly half of the respondents employ foreign expects in managerial and less than a third in non-managerial positions. The typical number of foreign expects within a company ranges between one and three positions. Over 67% percent of the responding organizations in the total sample had foreign expects from the parent company
- **Slovakia:** Almost the half (45%) of the subsidiaries participating in the survey didn't employ foreign expatriates in non-managerial positions. In those few companies that employed foreign expatriates in non-managerial positions permanently, the number of these expatriates was typically only four to five employees. Only one respondent employed more than 10 such expatriates. The presence of expatriates employed in managerial positions is more significant but only the 30% of the respondents employed foreign expatriates in such positions in the period examined. Where they were present, their number was typically one to five employees. From the examined sample we can say that half of the foreign expatriates are employed in managerial position and half of them in non-managerial position. More than the half (53%) of the responding organizations had foreign expects from the parent company while the others came from countries different from the country of the parent company.

### ***Local expatriates – inpatriates***

Impatriation “involves the transfer of subsidiary managers to headquarters for a specific period of time” [6].

- ***CEE:*** There was no such foreign deputation in more than 70% of the respondents in the total sample. The proportions of companies not sending employees to managerial positions and to non-managerial positions can be seen to be highest in four countries: Croatia, Estonia, Romania, and Serbia. If employees are sent abroad the typical numbers of employees were between one to three persons.
- ***Slovakia:*** More respondents sent than received employees abroad to non-managerial positions, there was no such foreign deputation in more than 60% of the respondents. Companies that sent employees abroad, sent usually 2-3 persons. But we had two companies in the sample which sent more than 20 people to foreign MNCs for a longer period. The proportion of companies not sending employees to managerial positions was higher (68%) than the proportion of those not sending employees to non-managerial positions. Companies that sent out employees who obtained foreign managerial positions, mostly sent 1-3 persons

## **5 Discussion**

### **5.1 The operation of HR departments**

Taylor et al. [15] describe the relationship between subsidiaries and parent company with the following three basic systems of relations:

- a) In extortive system of relations; HR systems developed in parent company are adopted without changes.
- b) In adaptive system of relations; local subsidiaries adapt HR systems adopted from parent company according to their local needs.
- c) In integrative system of relations; all good and applicable solutions are attempted to be spread and implemented in all units of the company regardless of their HR system of origin.

Lawler [9], [10] concluded from his research conducted among American subsidiaries operating in Asia and Europe, that the most dominant deciding factor in adoption and adaptation of HR systems is the size of local companies. The question is reasonable: which solution should be applied in a certain case? The above mentioned authors say that the system to be implemented depends on the sum of the impacts of internal and external factors that form and influence the organization [11]. In certain cases national culture of host country and legal, regulatory environment are considered influencing factors.

### ***The relationship between headquarters and local HR***

We found several approaches among the companies examined as follows:

- CEE: Some 15% of the subsidiaries reported hands off treatment from the headquarters HR staff, while in almost 6% of the situations the HQs provide central control.
- Slovakia: Almost all typical function of the HQ HR was chosen with the same frequency by the subsidiaries. Only one function was chosen with a lower frequency. The least typical function of the HQ HR is the absolute centralization which means that even the less important decisions are made by the HQ. The highest level of decentralization is when the HQ provides complete freedom to the subsidiaries. With hands-off the subsidiaries have to send only reports and information to the HQ HR.

### ***Changes in importance of HR functions***

- CEE: Human resource planning, employee communication and compensation and benefits were considered the most critical in the ranking of HR areas.
- Slovakia: Human resource planning was first in the ranking of HR areas considered most critical in the period examined. Industrial labour relations were chosen as the least important area of HR by the subsidiaries.

### ***Typical HR competencies for success***

From the somewhat completed list of HRM competency areas identified by [19] and [20] in 2009, the respondents considered the following three to be the most important:

- CEE: For the entire region the following three HR competencies were reported to be the most important: teamwork (13.2%), change management (13.1%) and personal credibility (12.5%). However, in the Hungarian, Romanian, and Serbian sub samples, results indicate personal credibility was reported as the most important criteria for HR competency success. Also, in the Romanian subsidiaries strategic contribution is seen as the second most critical area associated with HR competency success.

Slovakia:

- For the first rank (55%) the business knowledge (value chain, value creation) was chosen but teamwork and the knowledge of foreign languages have almost the same importance (45-45%),
- personal credibility, change management and quiche decision making with knowledge sharing were sorted out with the same frequency (41%) by the respondents,
- The least important competencies for success in 2009 were strategic contribution, HRMIS and the area of HR services.

### ***Primary responsibility of decision making in key HR functions***

Our current survey confirms the finding also established in other studies [4], [7], [8] that members of the management hierarchy have larger responsibility or control in some HR decisions and local employees of the HR department have in others.

- CEE and Slovakia: The majority of the respondents regard most of the interventions in the key functions of HR as the result of a joint decision in which the final decision is made rather by the local line management based usually on consultation with the HR department but in some cases only by the local management. It is more seldom that the responsibility attached to HR decisions is shared in a way that the final decision maker is the representative of the local HR department [20].

### **5.2 The role of external HR service providers**

Nowadays human resources are managed in many organizations with the involvement of external service providers. Besides traditional HR consultants, an increasing number of service providers appear who enter the market offering new services (e.g. labour leasing, outsourcing, interim managers, etc.).

CEE and Slovakia: External service providers were most often used in training and development from the key HR functions as reported by the respondents. They were also often involved in recruitment and selection and in the area of compensation and benefits. The practice of companies in this respect either didn't change or where it did, companies reported a decrease in the use of external partners.

### **Conclusion**

In the research project we examined the HR functions and practical applications of 22 MNC subsidiaries in Slovakia. This paper summarized the relevant findings in connection with the most important topics of the survey carried out in Slovakia in light of regional survey. We can conclude that the HR departments of the companies examined are relatively small as the number of HR staff was under than 5 persons in the case of more than 65% of the respondents, while there hasn't been any organization among the subsidiaries which hasn't got any HR staff. In the half of the companies examined, the relative weight of the training budget was under 2% in 2008. We also found a quite high proportion where the companies spent 10-20% or even more of the annual labour budget on training employees<sup>5</sup>. Our current survey confirms the finding also established in other studies [4] that members of the management hierarchy have larger responsibility or control in some HR decisions and local employees of the HR department have in others. As we have indicated earlier, the number of samples is relatively small; however, it can represent the practice of large multinational subsidiaries in Slovakia.

---

<sup>5</sup> The global average of this indicator calculated using the formerly mentioned Cranet international comparative HR database was 3.36%, the Eastern European index was 3.15% [4].

## References

- [1] ANTOŠOVÁ, M. *Practical aspects of People Development (In Slovak)* Košice: ESF BERG, 2008. ISBN 978-80-553-017-7.
- [2] BREWSTER, C. Comparing HRM policies and practices across geographical borders. In Stahl, G. and Bjorkman, I. (Eds.) *Handbook of Research in International Human Resource Management*. Cheltenham: Edward Elgar Pub., 2006. pp. 68 - 90. ISBN 1-9306 08-14-04.
- [3] BODREAU, J.W. *Retooling HR*. Boston (MA): Harvard Business Press, 2010. ISBN: 978-1422130070.
- [4] CRANET. *International Executive Report 2005, Cranet Survey on Comparative Human Resource Management*. Cranfield: Cranet-Cranfield University. 2006.
- [5] DELANY, E. Strategic development of multinational subsidiaries in Ireland. In Birkinshaw, J. and Hood, N. (Eds.) *Multinational corporate evolution and subsidiary development*. New York: St Martin's Press. 1998. ISBN 80-86419-62-2.
- [6] HARZING, A.W. – RUYSEVELDT, J.V. *International Human Resource Management*. London: SAGE Publication, 2006. ISBN 0-7619-4039-1.
- [7] KAROLINY, Zs. - FARKAS, F. - POÓR, J. The Hungarian and Central Eastern European characteristics of human resource management. (In Hungarian) *Vezetéstudomány*, 2009, Iss. 7-8, pp. 3–11. HU-ISSN 0133-0179.
- [8] KAROLINY, Zs. - POÓR, J. *Human resource management*. (In Hungarian) (Fifth revised edition) Budapest: Complex Publishing Co. 2010. ISBN 978 963 295 108 9
- [9] LAWLER, J. J. *Cultural and Institutional Determinants of HR Systems in International Affiliates of American Multinational Corporations*. Institute of Labor and Industrial Relations, University of Illinois, 2006.
- [10] LAWLER, J. J. *Cultural and Institutional Determinants of HR Systems in International Affiliates of American Multinational Corporations*. 2006. University of Illinois, Institute of Labor and Industrial Relations, 2006.
- [11] MURA, L. *Modely ekonomického rastu - kvantitatívny pohľad*. RELIK – Reprodukce lidského kapitálu. VŠE Praha, 2011, Praha. ISBN 978-80-86175-75-1
- [12] MURA, L. *Performance of Human Resource Management in an Internationally Operating Company*. Serbian Journal of Management. 2012, Vol 7, Iss. 1, pp. 115-130. ISSN 1452-4864.
- [13] PERLMUTTER, H.V. *The tortuous evolution of the multinational corporation*. Columbia Journal of World Business, 1969. Iss. January-February, pp. 9-18.
- [14] Slovak Agency for Development of Investment and Trade. *Foreign direct investment report*. Bratislava : SARIO 2010.

- [15] TAYLOR, S., BEECHLER, S. and NAPIER, N. *Toward an integrative model of strategic international human resource management*. Academy of Management Review, 1996, Iss. 21, pp. 959-985. ISSN 0363-7425.
- [16] UNCTAD *World Investment Report 2007: Transnational Corporations and Export Competitiveness*. United Nations, Geneva 2008, <http://stats.unctad.org/FDI/TableViewer/tableView.aspx?ReportId=4031>
- [17] UNCTAD. *World Investment Report*. United Nations, Geneva 2010.
- [18] VENAİK, S., MIDGLEY, D. and DEVINNEY, T. *Dual paths to performance: The impact of global pressures on MNC subsidiary conduct and performance*. Journal of International Business Studies, 2005, Iss. 36, pp. 655-675. ISSN 0047-2506
- [19] VOLOŠIN, M. – VOLOŠINOVÁ, D. *European integration and actual problems of the strategy of competitiveness increase*. In: Pribula, M. (ed.): Podnikanie - inovácie – spoločnosť č 2. Prešov: VŠMP ISM Slovakia 2009. ISBN 978-80-89372-16-4.
- [20] VOLOŠIN, M. *Cross-border Cooperation, Regional Development and Creation of Regional Innovation Strategies*. In: Fedan, R. – Makiela, Z. (ed.): Przyrodniczo-ekonomiczny potencjał regionów na pograniczu polsko-ukraińskim. PWSZ Jarosław 2008. ISBN 978-83-88139-35-2.

## Contact Address

### **Prof. Dr. Poór József, CSc.**

J. Selye University, Faculty of Economics, Department of Management  
 Bratislavská 3322, 945 01 Komárno, Slovak Republic  
 Email: poorj@selyeuni.sk  
 Phone number: 00421-35/3260 614

### **Prof. Dr. Martin Vološin, PhD.**

International School of Management,  
 Duchnovičovo námestie 1, 080 01 Prešov, Slovak Republic  
 Email: volosin@ismpo.sk  
 Phone number: 00421-51/758 17 98

### **Prof. Allen D. Engle, PhD.**

Eastern Kentucky University, Department of MGT, MKT and IB  
 521 Lancaster Avenue, Richmond KY, 40475-3102, USA  
 Email: allen.engele@eku.edu  
 Phone number: +1 859-622-6549

### **Ing. Renáta Machová, PhD.**

J. Selye University, Faculty of Economics, Department of Management  
 Bratislavská 3322, 945 01 Komárno, Slovak Republic

Email: machovar@selyeuni.sk  
Phone number: 00421-35/3260 694

**Dr. habil Mártonné Karoliny, CSc.**

University of Pécs  
Rákocsi út. 80, 7622 Pécs, Hungary  
Email: karoliny@ktk.pte.hu  
Phone number: 0036-72/ 501 599

Received: 23. 03. 2012  
Reviewed: 25. 06. 2012  
Approved for publication: 01. 11. 2012



# SELECTED PROBLEMS ASSOCIATED WITH MODELING THE BIGGEST COMPENSATIONS IN NON-LIFE INSURANCE

Ewa Poprawska, Anna Jędrzychowska

***Abstract:**Modelling the highest compensations are very important for insurance companies, as more and more policies now can generate high claims (for example third party liability insurance, property, especially connected to catastrophic events). In modelling extreme values of compensations paid by insurance company it is possible to use different models (exponential, gamma, Pareto distribution are most common) for typical values and different ones for the highest compensations (for example Generalised Pareto distribution). In this case however a problem of choice of the point, in which the change of the way of modelling is taking place appears. The paper is devoted to methods useful in choosing this point, that can be found in literature. Using simple example of the data, these methods can be analysed to find their advantages and disadvantages. All of the presented methods are mainly based on the analysis of graphs of selected parameters, which makes the results obtained are not strict guidelines, however, provide indicative results.*

***Keywords:** Extreme value modeling, Insurance claims.*

***JEL Classification:** C16, , C46, C65.*

## Introduction

From the standpoint of insurance proper premium calculation is crucial in ensuring financial balance. The base pure premium calculation is the expected value of random variable, with which is described by the amount of compensation. Therefore, proper modeling of the random variable is important for insurance.

In case of damage of a typical size insurance companies generally have a sufficiently large amount of data that the selection of the appropriate distribution is not a problem. Furthermore, it is also possible to use an empirical distribution.

However, in the case of insurance, in which the terms of the contract allow the occurrence of exceptionally high compensation (the need to pay such compensation may occur eg in connection with the occurrence of events that can be described as natural disasters), there is a problem associated with the occurrence of a small number of observations, based on which can be requested on the form and distribution parameters. At the same time it is precisely these claims very strongly affect the expected value of damages.

Also from the viewpoint of reinsurer the largest claims are of particular importance. This mainly applies to the excess of loss reinsurance, in which the reinsurer assumes liability for damages, which amount exceeds the value of the contract of reinsurance.

Thus, modeling is particularly important damage from the right tail of the probability distribution of random variable describing the amount of damages.

## 1 Modelling extreme losses

### 1.1 Approaches to modeling extreme losses

The modeling of extreme values can distinguish several approaches (for [3]). The first approach is based on the distributions of extreme values. Based on the Fisher-Tippett theorem can be concluded that the maximum compensation can be modeled using the generalized extreme value distribution (GEV).

The second approach is to match the distribution for all observations or for values that exceed a fixed value (using the censored distributions and conditional). Problems with this approach will focus on the further part of the paper. If the distribution is matched to all observations, it may well describe a typical value, while for higher values may be poor fit to empirical data. Thus, often it is reasonable to separate modeling of typical damage and the values derived from the tail distribution - the use of censored distributions and mixtures of distributions. In this case, however, there is the problem of choosing the point at which a change in modeling.

If the amount of compensation from the tail of the distribution are modeled separately, we introduce the distribution function of the excesses over threshold  $u$  (conditional excess distribution) defined as:

$$F_u(x) = P(X - u \leq x | X > u) = \frac{F(x+u) - F(u)}{1 - F(u)} \quad (1)$$

Of course, knowing the conditional excess distribution we can express a probability distribution for the original value  $x \geq u$  as follows:

$$\hat{F}(x) = (1 - F_n(u))F_u(x-u) + F_n(u) \quad (2)$$

where  $F_n(x)$  is a distribution function for typical values, or it can be empirical distribution either.

On the basis of Pickands-Balkema-de Haan statements (see [5]) for a wide class of distributions of the conditional excess distribution for sufficiently high values of  $u$  can be approximated by a generalized Pareto distribution (GPD):

$$G_{\xi, \sigma}(x) = \begin{cases} 1 - (1 + \xi x / \sigma)^{-1/\xi} & \text{dla } \xi \neq 0 \\ 1 - \exp(-x / \sigma) & \text{dla } \xi = 0 \end{cases} \quad (3)$$

Additional parameter ( $\mu$ ) can be introduced as follows:

$$G_{\xi, \mu, \sigma}(x) = G_{\xi, \sigma}(x - \mu) \quad (4)$$

$\xi$  can be interpreted as a shape parameter,  $\beta$  as a scale parameter.

It can be shown that if the conditional distribution excess is approximated by a generalized Pareto distribution, then (2) also has a generalized Pareto distribution with the same parameter  $\xi$  and  $\tilde{\sigma} = \sigma(1 - F_n(u))^\xi$ ,  $\tilde{\mu} = \mu - \tilde{\sigma}((1 - F_n(u))^{-\xi} - 1)/\xi$ . Thus there are strong theoretical arguments supporting the modelling of the probability of extreme values of compensation using the generalized Pareto distribution.

In case of modeling the distribution of values that exceed the threshold  $u$  using GPD, threshold selection plays an important role. If this value is too low, then the approximation of the distribution is not justified, and if too high, the number of observations on which the distribution of estimates of parameters is based will be too small.

## 1.2 Choice of the optimal value of threshold $u$

In literature you will find various hints to help you determine the value of  $u$ , but none deal with the problem in an unambiguous manner. One of the simplest suggestions is to set the threshold at a level of empirical quantile.

Another method is based on the analysis of the shape of the mean excess function – MEF:

$$e(x) = E(X - x | X > x) = \frac{E(X) - E(X \wedge x)}{1 - F(x)} \quad (5)$$

with empirical function (see [5]):

$$e_n(x) = \frac{\sum_{i=1}^n (X_i - x)^+}{\sum_{i=1}^n I_{\{X_i > x\}}} \quad \text{where} \quad I_{\{X_i > x\}} = \begin{cases} 1 & \text{dla } X_i > x \\ 0 & \text{dla } X_i \leq x \end{cases} \quad (6)$$

For heavy-tailed distributions this function is increasing, otherwise decreasing, while for an exponential distribution it is constant. For a Pareto distribution, also for GPD, it is increasing and linear.

It can therefore be concluded that  $u$  should be set at a level from which the graph of the function of MEF is approximately linear. This criterion may be useful for preliminary analysis of empirical data, but it should be mentioned that for a small number of observations MEF, even for observations generated from a particular

distribution, may differ significantly from the model run, as illustrated by the following charts. The largest differences occur for the highest value, which is in the area's most interesting from the perspective of modeling extreme values.

**Fig. 1: MEF for observation generated from a) Pareto and b) exponential distribution compared with theoretical value of MEF**

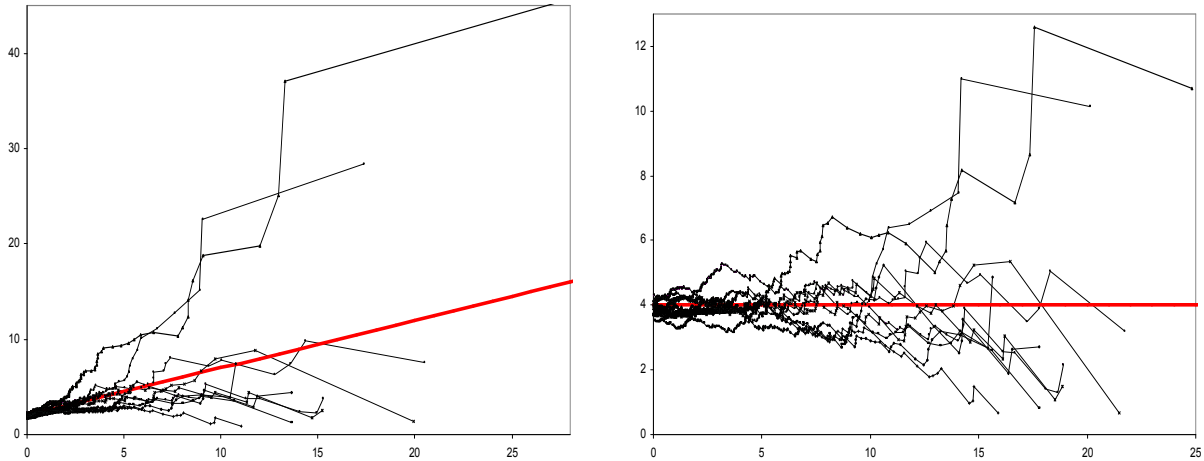

Source: own studies

Another way of preliminary data analysis is to analyze the shape of the quantile plots (empirical quantiles compared with theoretical - derived from the fitted to the empirical data distribution). This is a graph of points:

$$\left\{ \left( X_{k,n}, F^{-1} \left( \frac{n-k+1}{n+1} \right) \right) : k = 1, \dots, n \right\} \quad (7)$$

where  $X_{k,n}$  is  $k$ -th empirical quantile.

If the matched observations well describes distribution, then the quantile plot is approximately linear. Distributions characterized by heavier tails the plot deviates from a straight line up for the points describing the highest quantile. The threshold should be set at a level where the plot begins to deviate from straight line.

Another way (cf. [1]) is a graph showing dependency between  $p$ -th quantile estimated using GPD and the threshold, which is a chart of points:

$$\left\{ (u, \hat{x}_p) : u \geq 0 \right\} \quad (8)$$

where  $\hat{x}_p = u + \frac{\hat{\sigma}}{\hat{\xi}} \left( \left( \frac{n}{N_u} (1-p) \right)^{-\hat{\xi}} - 1 \right)$  is maximum likelihood estimator of p-th quantile.

The threshold  $u$  should provide a stabilization in the values of a selected quantile.

Finally, when choosing an optimal threshold value may be helpful to analyze the value of the estimators of parameters of the generalized Pareto distribution, depending on  $u$ . The parameter which most affects the thickness of the tail distribution is the shape parameter  $\xi$ . A graph of the values of the threshold amount, together with marked confidence intervals, allow to find a compromise between error and stability of parameter estimation.

## 2 Problem solving – empirical example

The purpose of this article is the comparison of proposed in the literature criterion for selection threshold. Calculations used in the analysis are based on 1000 observations generated from the Pareto distribution. At the same time in a better way to bring the behavior of data from heterogeneous portfolio of policies, mixing variable was introduced. Expected value is not constant, but in its place a mixing variable normally distributed  $N(100,40)$  was introduced. Similarly the standard deviation -  $N(80, 20)$  - distribution of parameters describes the structure of risk in the portfolio.

**Fig. 2: Empirical density (left chart) and distribution function (right chart) of data used in an example**

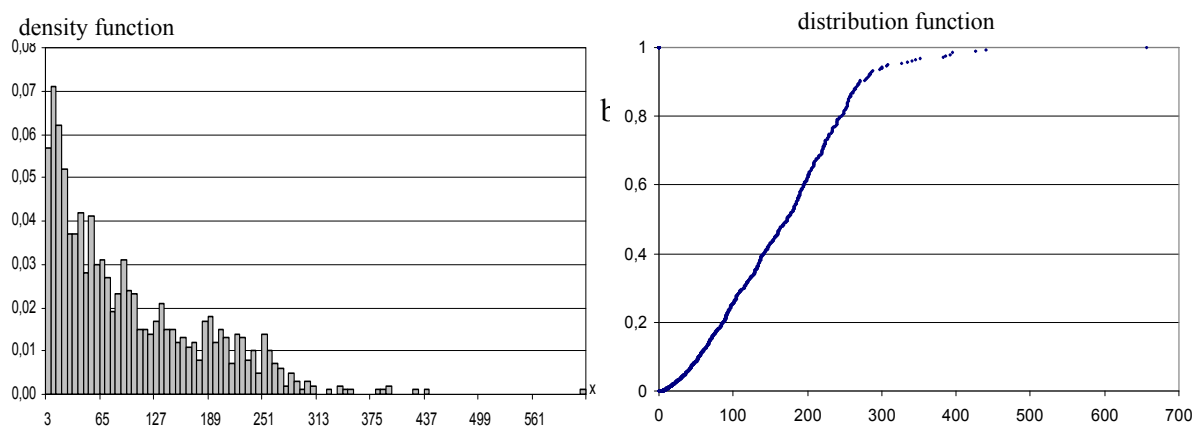

Source: own studies

The first way of finding optimal value of threshold  $u$  is to analyse MEF function (Fig 3). A clear change in the nature of the graph is visible for values close to 250. The points corresponding to values greater than 250 are beginning to increase. As it is obvious it is quite difficult to give one good answer to the problem of finding threshold  $u$  in this case.

**Fig. 3: Empirical MEF for the data used in an example**

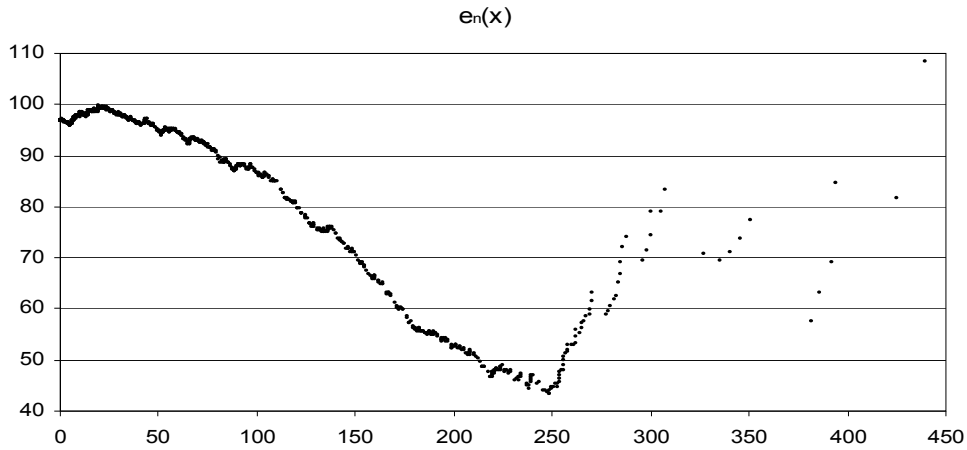

*Source: Own studies*

Second way of finding  $u$  is to use quantile plot (Fig 4 – compared to Pareto distribution. Similar deviations from the straight line appear near the values of 200-250. Data compared with distributions such as gamma, Weibull, Burr, GPD gave very similar conclusions.

**Fig. 4: Quantile plot (data vs Pareto distribution)**

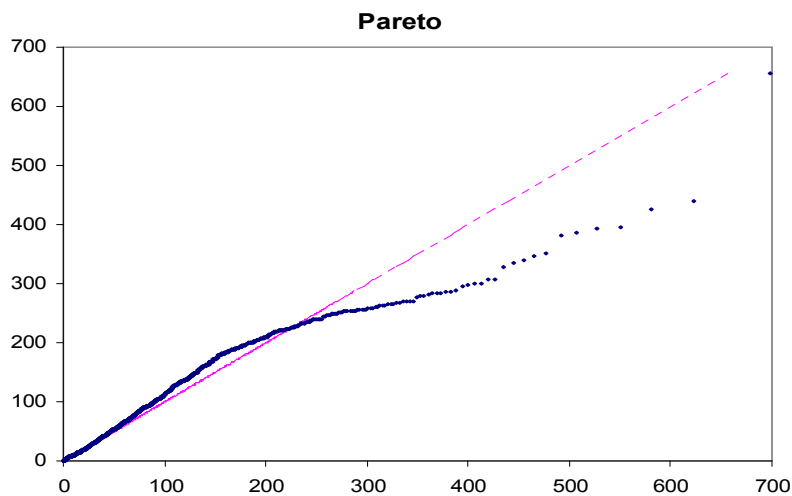

*Source: Own studies*

The next two charts (Fig 5 and Fig 6) illustrate the value of the maximum likelihood estimators of parameters of the generalized Pareto distribution, depending on the choice of the threshold  $u$ . For the lower thresholds than 170 of the estimators of parameters  $\xi$  (Fig 5) and  $\sigma$  (Fig 6) differ significantly from those obtained in case the higher values of  $u$ . The values of both estimators stabilize for a threshold of about 170 to about 250. Above  $u = 250$  the number of observations above the threshold drops below 40, for  $u > 270$  falls below 30.

**Fig. 5: Estimator of parameter  $\xi$  depending on threshold  $u$**



*Source: Own studies*

**Fig. 6: Estimator of parameter  $\sigma$  depending on threshold  $u$**

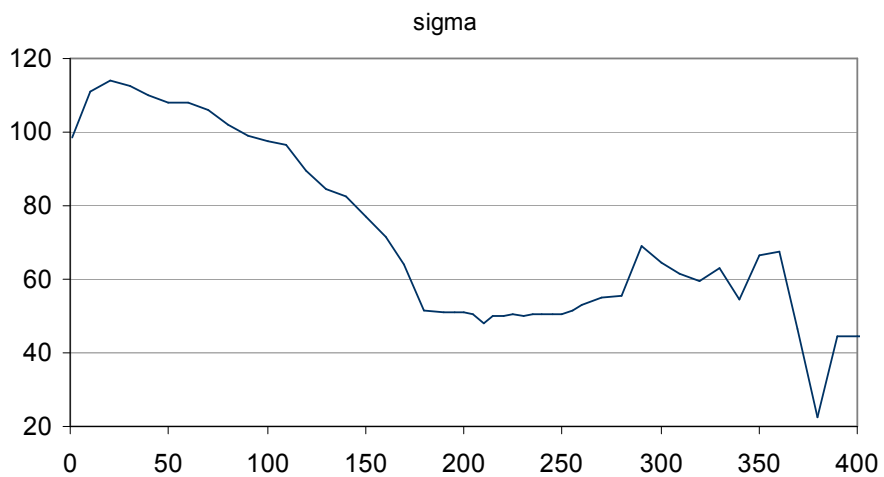

*Source: Own studies*

Similarly it can be observed stabilisation of 0,95 quantile (Fig 7) for threshold  $u$  lower than 250. For bigger values of  $u$ , the values of 0,95 quantile starts to be unstable.

**Fig. 7: 0,95 empirical quantile of the data**

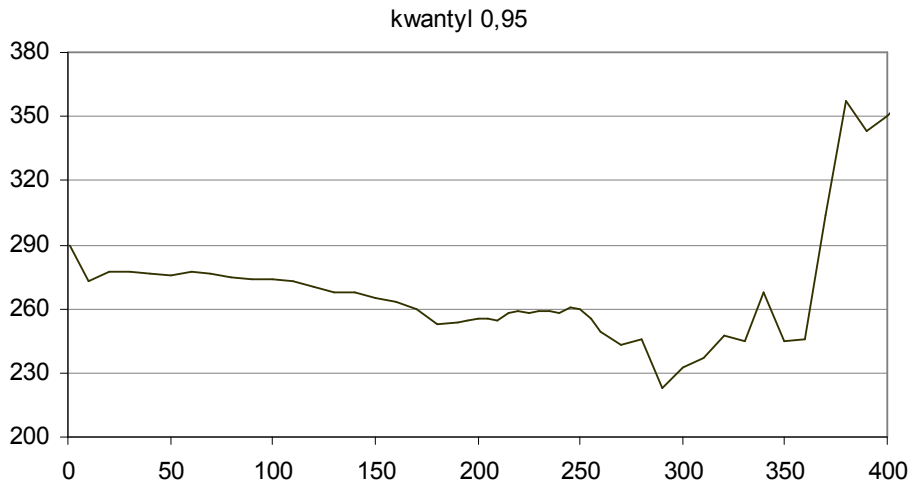

*Source: Own studies*

Based on the foregoing, it can be assumed that the optimal threshold value should be between 170 and 250th. The following graph (Fig 7) shows a comparison of the empirical distribution function with fitted GPD. The value of the threshold  $u = 223$ , the parameters of GPD were estimated on the basis of 100 observations.

**Fig. 8: Empirical distribution with GPD for  $u=223$**

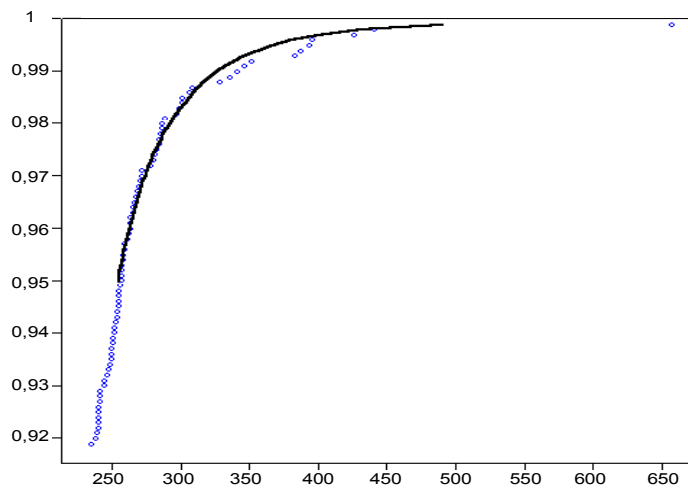

*Source: own studies*



## Conclusion

All these ways of determining the optimal thresholds are based on visual analysis of graphs. Thus, observations on stabilization of the value estimates may differ from the conclusions of others. Moreover, these methods allow to determine the indicative ranges, which should include a threshold value, the final decision is taken arbitrarily. However, despite the imperfections, they provide information that can make this decision much easier.

## References

- [1] BASSI F., EMBRECHTS P., KAFETZAKI M. *A survival kit on quantile estimation*, available at WWW: <[www.math.edu.ethz.ch/finance](http://www.math.edu.ethz.ch/finance)>
- [2] DAYKIN C.D., PENTIKÄINEN T., PESONEN M. (1996). *Practical Risk Theory for Actuaries*. Chapman & Hall, London.
- [3] EMBRECHTS P., KLÜPPELBERG C., MIKOSCH T. (1997). *Modelling Extremal Events for Insurance and Finance*. Springer - Verlag, Berlin.
- [4] KLUGMAN S., PANJER H.H., WILLMOT G.E.(1998). *Loss models: From Data to Decisions*. John Wiley & Sons, New York.
- [5] MC NEIL A.(1997). *Estimating the tails of loss severity distributions using extreme value theory*. ASTIN Bulletin.

## Contact address

**Ewa Poprawska, PhD**

**Anna Jędrzychowska, PhD**

Wroclaw University of Economics

Department of insurance

ul. Komandorska 118/120

53-345 Wroclaw

E-mail: [ewa.poprawska@ue.wroc.pl](mailto:ewa.poprawska@ue.wroc.pl) [anna.jedrzychowska@ue.wroc.pl](mailto:anna.jedrzychowska@ue.wroc.pl)

Phone number: +48 71 36 80 158

Received: 31. 01. 2011

Reviewed: 16. 03. 2011

Approved for publication: 16. 01. 2012

# THE POTENTIAL OF ENLARGEMENT OF THE EUROPEAN UNION

**Martin Sobotka, Lucie Sobotková, Zdeněk Řízek**

***Abstract:** The article deals with the possibilities of expansion of the European Union, not only by the membership, but also by the other integration methods. In the basic documents of the European Union, which form the legal basis of the arrangement of the European Union is not the geographical jurisdiction strictly mentioned to the old continent. This enables further enlargement of the European Union outside the geographic territory of the European continent. In addition, the European Union has the possibility to use different degrees of integration, without the condition the potential states must be forced to be members of the European Union. Outside the European Union is mentioned the African continent and its selected regions, region of North African countries and the region of South African countries in this article. All countries (European and African) have been submitted by indicatory the Failed States Index, and with the help of indicators of World Bank Data Set has been processed in the time series, which are ten-years development in selected indicators.*

***Keywords:** The EU, The AU, The EU enlargement, Security, Economic indicators, Analysis.*

***JEL Classification:** F15, F59.*

## **Introduction**

One of the specific globalizing effects is, for instance, the process of the EU enlargement. This process is carried out continuously for the entire existence of the European Union and its previous groupings. Enlargement of the European Union is an expression of efforts to secure peace, the elimination of threats of further warfare and thus prevent any armed conflict, not only on its own territory or the territory of their own members.

In general, with the existence of a safe state (and the supranational region) is linked with the economic advantageousness and stability. Using the economic benefits of the international treaties and agreements were originated the European Coal and Steel Community (the ECSC) as the first European integration. With economic and security stability is generally linked a safe and stable environment as well. The same is valid for the European Union.

The aim was to compare the states of the European Union with the states of the African Union (AU) which are localized in two different regions – the states of the North African region and the States of the South African region.

## **1 Potential enlargement of the European Union**

Enlargement of the European Union is not linked only to the membership in the European Union, but the expansion of the European Union can be in many different

grades, which are qualitatively at other levels. It should be noted that the European Union, whose rise to the end of the forties, respectively in the early fifties of the last century, was primarily led by effort to avoid the possibility of further destructive conflict. Evidence is in both of World Wars in a relatively very short time span, which took less than a half century.

The further an objective factor of safety are historical animosities that exist in Europe, in particular thanks to the integration processes, overcome even between states, which were considered in the long term for the enemy (e.g. France and England, Sweden and Denmark). On the other hand it should be added that the tension between Greece and Turkey continues, even though they are in the same security community [6].

The issue of conflicts in the world today is significant in connection with the further expansion of the European Union, and therefore, for the international relations of the European Union with its surroundings. It's not in such cases the enlargement of the European Union by another member of the European Union, but a different level of relationship with the environment of the European Union, allowing for not only the good-neighbourly relations, but also the security and stability of the European region. A different form of the enlargement of the European Union is one of the priority plans to provide the safer future in the following years, more stable and without significant complications.

### **1.1 The current process of enlargement of the European Union**

The enlargement of the European Union goes in several directions in several levels. The main distinguishing aspect is the internal enlargement within their territory of the European continent. It is possible to calculate the external enlargement of the European Union with more possibilities, although they have limited directions, where to expand, but less limited options how to widen.

Firstly, the European Union has a primary interest in their integrity and stability on its own territory – it means the European continent. There is the further negotiation of the rapprochement with those European States which are not yet members of the European Union, and at all levels, in order to achieve the highest possible representation of all of the European states in the European Union.

In the next sequence has the European Union interest to be expanded outside the European continent. This type of spread may be maintained by land but only two main geographical directions: One of the possibilities is to the East, where there are States, such as Belarus, Ukraine and the states of the former Soviet Union. The second option is the south-easterly direction to the Middle East. There is interest on the part of the European Union in Israel, which is in the region with the highest economic level and other parameters, which comply with the conditions of entry of all entities in the region. There is Turkey which is geographically on the way to other countries, the country that has the fast growing economy and the growing respect in the region. Both countries, however, have their own specificities, which are not very welcome in the European Union.

It appears that the enlargement of the European Union to the South to/on the African continent can be the fairly realistic possibility. But it is the direction which is behind the European continental borders as one of the essential conditions for the existence of regional transnational complex.

## **1.2 Criteria for the enlargement of the European Union**

The basic criteria for the admission of a new Member of the European Union are enshrined in the article Nr. 49 of the Treaty on European Union (the so-called The Lisbon Treaty, which is valid from 1. December 2009). Under this Treaty, "any European State which respects the values referred to in the article 2 and a commitment to their promotion, may apply for the membership in the Union". These values are referred to in the article 2 respect for human dignity, freedom, democracy, equality, the rule of law and respect for human rights, including the rights of minorities.

Even if this article 49 speaks about European State, it is not in the founding treaties of the European Union, what the territorial scope is on the European continent means, or what the minimum part of State must be part of the European continent (e.g. Turkey, which is the current official candidate for membership in the European Union, is only three per cent of its territory in Europe.)

Even though the European integration is primarily linked to the European territory, is not based strictly on geographical jurisdiction. Today there are some non-European territories, which are incorporated into the European Union:

- Cyprus geographically belongs actually to the Middle East region, which is the part of Asia;
- French overseas departments are in different overseas territories: the largest is French Guyana in South America, the Caribbean islands of Guadeloupe and Martinique, and the island of Reunion in the Indian Ocean;
- likewise Spain has its own enclaves Ceuta and Melilla on the North African coast in Morocco.

It is given by these realities the geographic criterion for the integration into the European Union as such in itself cannot survive.

However, there are others, the more precisely criteria for entry, which was created at the meetings of the European Council in Copenhagen in 1993 (the three Copenhagen Criteria) and in Madrid (the Madrid Criterion):

- The criterion of political existence of stable institutions guaranteeing democracy, the rule of law, human rights and respect for and protection of minorities;
- the economic criterion: the country must have a functioning market economy capable of withstanding the competition and market forces within the European Union;
- the criterion of acceptance of the *acquis communautaire* (which is used for the legal regulations of the European Union) and the obligations of membership, including adherence to the aims of political, economic and the Monetary Union

and the implementation of, i.e. in particular, the harmonization of domestic law with the law of the European;

- sufficient administrative and judicial structures for the implementation of all the obligations of membership.

Even these criteria are, however, subject of development, i.e. those countries, which are currently failing, for example from the economic point of view it may be, after the implementation of needed reforms, successfully realised. In addition, the Lisbon Treaty has already provided in that article 49 that "the criteria for accession, on which shall be agreed by the European Council, will be taken into account", i.e. member states may, by agreement, to formulate additional membership conditions. Formulated the initial conditions are not for the non-democratic States prone to violent resolution of disputes is too easy. But on the other hand, benefits from one of the degrees of integration with the European Union are not negligible and of such possibilities must be considered seriously.

### **1.3 The security of the European Union and abroad**

A qualitative breakthrough in the process of the European integration would be the unification of foreign and security policy of the Member States, because these forms are the core of the sovereignty of States. From practice and from the text of the Lisbon Treaty shows that the foreign policy of the European Union remains a matter for consensus – therefore preserves the decision-making mechanism, which protects the interests of the European Union Member States more than the interests of the European Union. This means that the foreign policy of the European Union remains the common denominator policies of the Member States, which is uniform if there is a consensus, and if they are in the foreign policy of the individual Member States of the European Union some differences.

The neo-functional logic of the regional integration following the logic of the emergence of the European Union in the context of the ideas of neo-liberal institutionalism doesn't want to create a world-ruling by a one-shot act or a reform from above, but wants to create conditions for peace and the emergence of new political institutions successively through specialized international institutions. Unlike the federalist papers differ in the following points:

- statesmen and the professional diplomats are not the engine of changes, but technical experts who are specialists in the formation and change of international organisations, specialised on integration activities in certain narrow economic-social area,
- the full functioning of this specialised integration has resulted in the penetration of pressures integration in other areas, and the final result of the economic-social integration is the political integration,
- the integration into a new political unit is the regional integration; the issue is not about the creation of the world state, but about creating a local political player with the ultimate aim to create a federal state within the borders of the continent. [8]

It can be only added to the following points, that even if there is the point, as in other cases involving regions, particularly on the issue of the European Union, so all the theoretical background and practical knowledge are finally going towards the improvement of the functioning of the European Union. It can be possible with the minimum theoretical modifications to implement the issues of selected regions in Africa.

The enlargement of the European Union is possible in at least two fundamental planes: primarily for new regular members of the European Union and, as well, one of the other of the standard ways of integration than the membership in the European Union (see Tab. 1). The different types of integration are progressively extended or reduced according to the depth of integration.

The European Union is interested in further expansion and cooperation with other states in the classic combination of political, economic and social factors, which all together can provide a greater stability and security in the European region. With this strategy, a permanent stability and security related term *cordon sanitaire*. At the present time is the term used for the expression of the need in the vicinity of the territory of the European Union space that is at least politically neutral, if not just friendly. The motive for the surrounding states is the certain degree of integration with the European Union, if not directly the potential membership in the European Union. Its economic power of the European Union what is a major player and a very attractive partner for political and economic relations and its existence allows achieve some long-term stability within the region, as well as in its surroundings. So the European Union becomes a very valuable neighbour and it is necessary to count on it in the future.

**Tab. 1: The Classification of Regional Integration**

	Member states set lower tariffs on imports from one another member	Free trade is established between members states	There are free trade areas which operate a common external policy	There are customs unions within which capital and labour move freely	There are common markets except that fiscal and monetary policy which is dominated by a central authority
Preferential tariff areas	X				
Free trade areas	X	X			
Customs unions	X	X	X		
Common markets	X	X	X	X	
Economic and monetary	X	X	X	X	X

Source: [3]

Good relations, however, is to be developed from both sides. The European Union has a great opportunity, and the possibility of their surroundings ensure a system of mutually beneficial economic relations and treaties that will strengthen stability and security. This philosophy, the expansion of the European Union by means of differentiated integration, it is possible to create from surrounding states temporary

previously mentioned *cordon sanitaire*, that would allow to stabilize the nearest surroundings and with this strategy to continue expanding the geographical rings in graduated stages.

## 2 Methods

To highlight the differences between the EU States and the selected regions of the African Union (states of North African region and the states of the South African region) were used in the analysis of selected indicators of statistical data from World Bank Data Set. In the selection of statistical data was taken the criterion of consistency of these data. For this reason it was used for obtaining the data from individual national economies and the individual indicators of one database. Data consistency could not be ensured if we used more different databases within a single indicator. Different databases may use different methodologies of data collection, the use of different values of the variables. It may be individual database for the same year. The years represent the period of time for which they are all input data fully complete. Another requirement was that the indicators have available data at least the 10-year time series.

Individual indicators were for the states in three selected regions (the states of the EU, the states of the AU in north region and the south region). The Data for each region was recalculated by the diameter.

The average values of each examined indicators were determined in terms of a weighted average. That average was achieved through the following relationship, where:

$GDP_i$  gross domestic product of region  $i$ ,

$P_i$  total population of region  $i$ ,

$i = 1, 2, \dots, n$

values marked  $\cdot$  represent the sum of examined variables.

$$\frac{\sum_i GDP_i}{\sum_i P_i} = \sum_i \frac{P_i}{P_\cdot} \cdot \frac{GDP_i}{P_i} = \frac{\sum_i P_i \cdot \frac{GDP_i}{P_i}}{P_\cdot} \quad (1)$$

and because

$$\frac{\sum_i P_i}{P_\cdot} = 1 = wP_i, \quad (2)$$

it is possible to write down the previous relation as

$$\sum_i wP_i \cdot \frac{GDP_i}{P_i}. \quad (3)$$

## 3 Problem solving

The primary factor determining the EU's enlargement is its security. Other criteria (e. g. convergence criteria, etc.) are important indicators, which should be met, the most important is security view.

As an auxiliary criterion for the assessment of the security situation states was selected the Failed States Index (FSI) processed by the Fund for Peace. The selected states of Europe and the African Union are shown in Tab. 2, including values and order of states, which is referred by the FSI.

Only three European Union Countries had been got in the order of the countries listed in the Tab. 2 by the FSI. All of other countries in the Tab. 2 had been from AU.

These three EU countries, which had been in accordance with the evaluation of the EU from the worst-placed FSI (all of other EU countries are better assessed under this index) had been used as a benchmark for the position of the countries of the EU and the AU by the FSI.

**Tab. 2: The Failed States Index overviewed regions**

Country	Region	2009		Country	Region	2011	
		Score	Rank			Score	Rank
Egypt	North - AU	89	43	Egypt	North - AU	86,8	45
Swaziland	South - AU	82,4	65	Mozambique	South - AU	83,6	57
Lesotho	South - AU	81,8	67	Swaziland	South - AU	82,5	61
Mozambique	South - AU	80,7	72	Lesotho	South - AU	80,4	71
Algeria	North - AU	80,6	73	Algeria	North - AU	78	81
Morocco	North - AU	77,1	93	Morocco	North - AU	76,3	87
Namibia	South - AU	75,6	69	Namibia	South - AU	71,7	104
Libya	North - AU	69,4	112	Tunisia	North - AU	70,1	108
Cyprus	EU	68,9	114	Libya	North - AU	68,7	111
Botswana	South - AU	68,8	116	Botswana	South - AU	67,9	113
Tunisia	North - AU	67,6	121	Cyprus	EU	67,6	116
South Africa	South - AU	67,4	122	South Africa	South - AU	67,6	116
Bulgaria	EU	61,5	132	Romania	EU	59,8	126
Romania	EU	61,3	129	Bulgaria	EU	59	129

*Source: Authors by [7]*

It is an essential for a stable situation in each country to have economic indicators. The selection of the indicators has been derived from the main economic indicators, which are shown by the World Bank in its database (the World Bank Data Set). At the same time the selection was influenced by the availability of the selected data, which are especially on the African continent often incomplete. Moreover, the selection of separated data was examined only if they were continuously in the time series of ten years (or nine years because of missing data for the year 2010 yet).

The situation of each region is described by the following images. With the help of selected indicators, the data are displayed for the last ten (or nine) years. It was elected the gross domestic product as the first indicator for calculation on the labour force, which describes the labour productivity.



**Fig. 1: Labour Productivity of regions (current USD)**

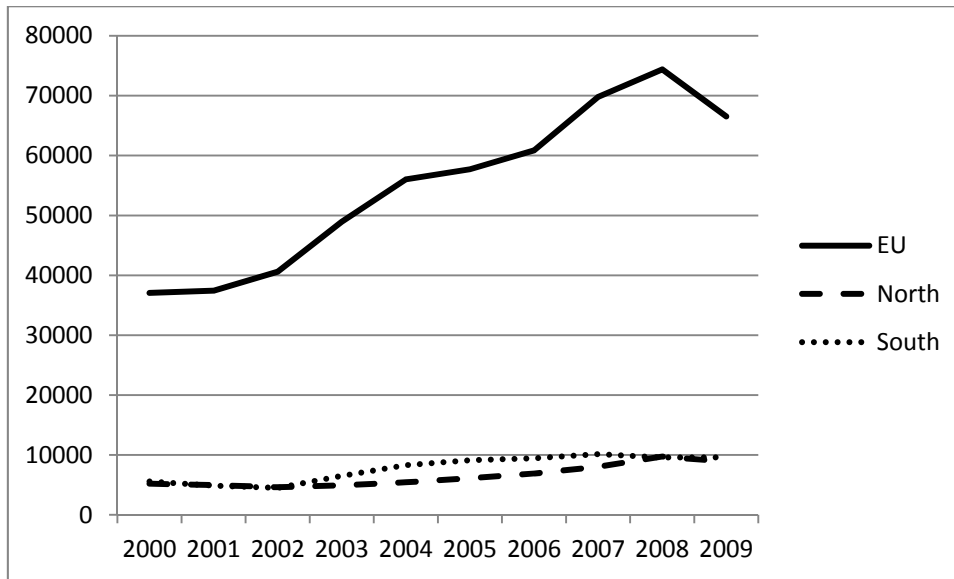

Source: Authors by [11]

Another indicator was the gross domestic product, which was to ensure the comparability of the development trend of economic performance of differently big countries recalculated per capita.

**Fig. 2: GDP per capita (current USD)**

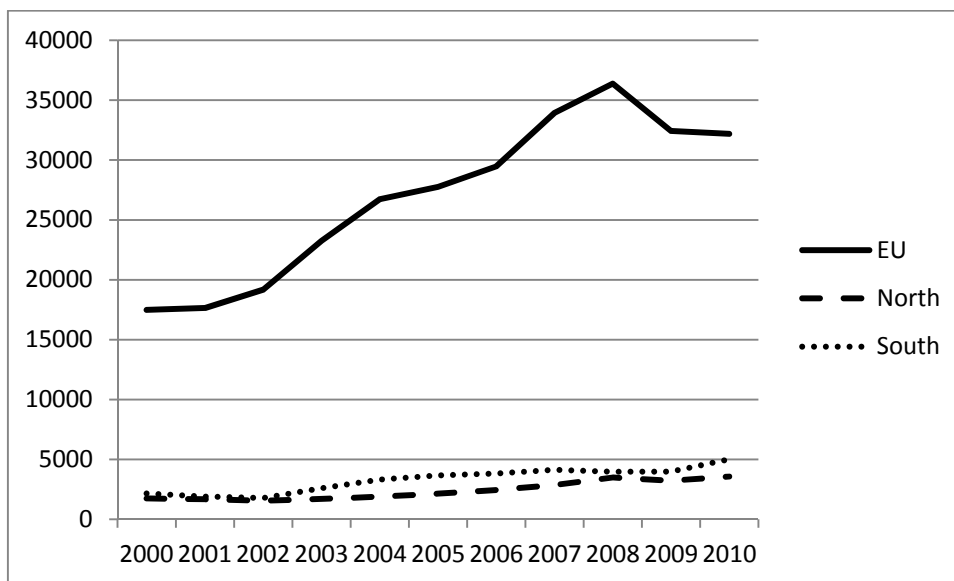

Source: Authors by [11]

The next indicator is the annual percentage rate of growth of the gross domestic product at market prices based on local currency. Gross domestic product is the sum of gross value added manufacturers in the domestic economy plus all taxes and minus any subsidies not included in the value of products

**Fig. 3: Growth of the regions (annual %)**



Source: Authors by [11]

Foreign direct investment with large tributaries is operating in the economy, which is required as a net inflow of investments, with a permanent participation in the management of the business operations in the economy rather than investment. This is the sum of equity capital, reinvestment of profits, other long-term capital, and short-term capital, as indicated in the balance of payments.

**Fig. 4: FDI per labour forces (net inflow, in current USD)**

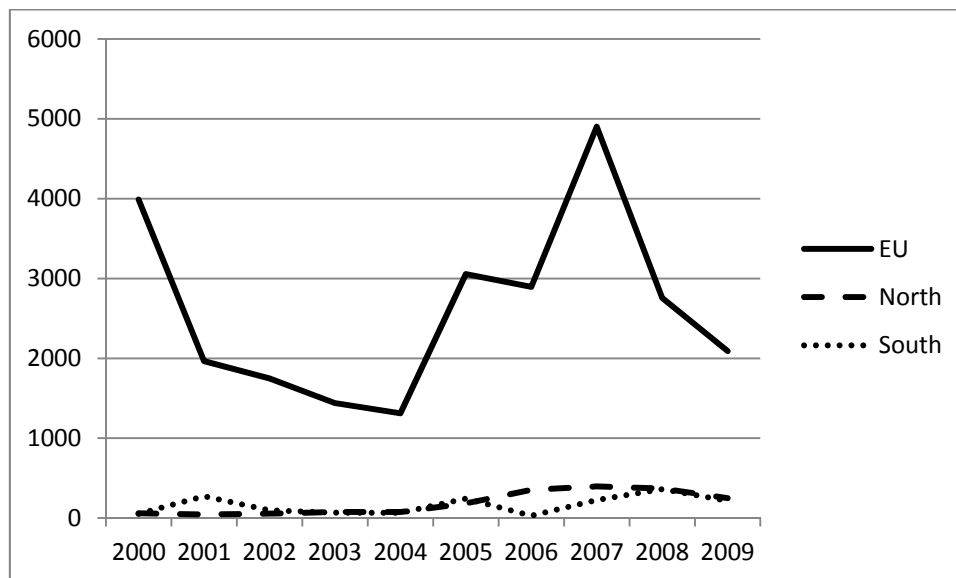

Source: Authors by [11]

Health expenditure per capita is the share of the total health expenditure, which is the sum of public and private health expenditure, and the total population. This includes the provision of health services, family planning, nutrition, activities and emergency assistance for health.

**Fig. 5: Health expenditures (% of GDP)**

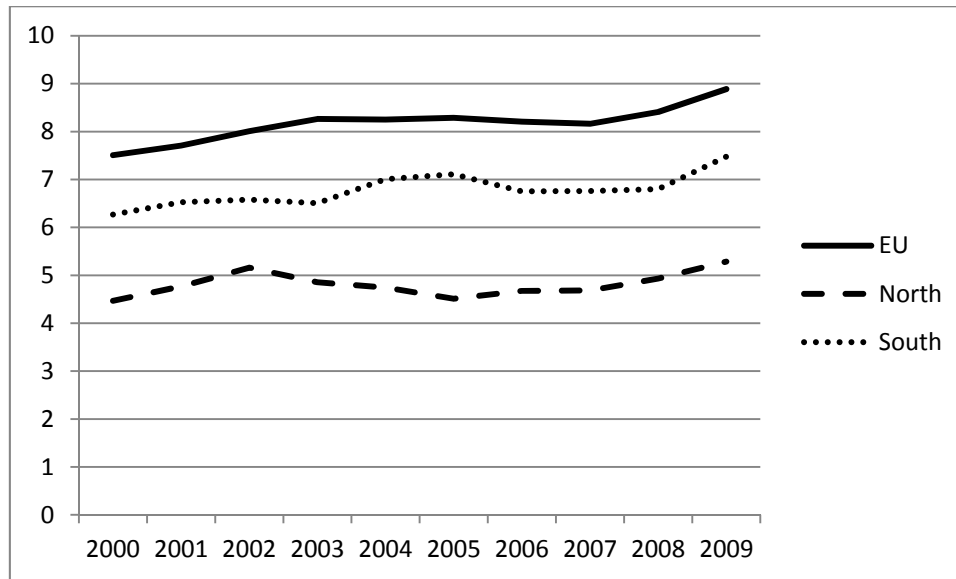

Source: Authors by [11]

Internet users are people with access to the global network. This indicator is in the last time one of the often used. Although not a major indicator, its importance lies in the illustration of the current trends in communication through IT. In fact, it is one of the main accelerators in economic and social development.

**Fig. 6: Internet users per capita**

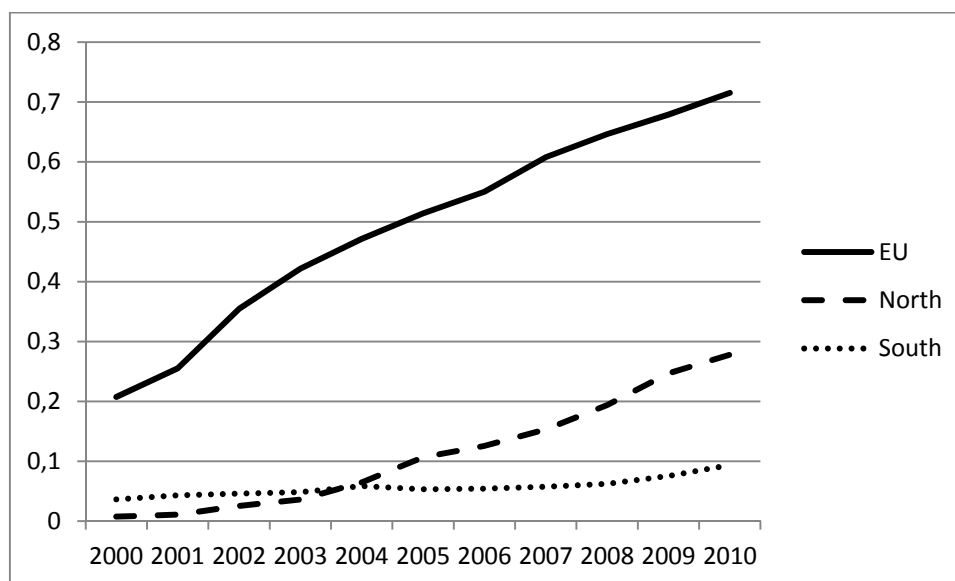

Source: Authors by [11]

#### 4 Discussion

The first two of the examined indicators of the gross domestic product related to the work forces and to the population. They are essentially interchangeable and show a similar trend.

The economic growth in African countries is in a different position than it is in the situation in Europe. For the AU countries this indicator is the fundamental. From Figure 3, it is apparent that the economic growth of African countries is in certain aspects different from the situation of the countries of the EU. For instance, in 2009 the AU states were not so much affected by the worldwide by the ongoing financial crisis. This situation is essential for any EU decision on its further enlargement through a different degree of integration (see Table 1) with African countries. In particular, this fact could be positive for the integration of new countries into the EU.

From this analysis it is clear that the European Union is to qualitatively different from the countries North African and the South African region. Performance of European countries is at a much higher level. Nevertheless, African countries have the advantage in a much higher economic growth, which, moreover, is not susceptible to global negative trends in the economic area.

In the case of the AU, the indicator of foreign direct investments is at a lower level in comparison with the countries of the EU. From the chart, however, is the apparent significant volatility in the trend in investments on the continent. So, once again, shows a greater sensitivity of European countries on global development.

Of the indicators of social nature is a major indicator of health care expenditure. Shows how the country can take care of their populations. It is one of the toughest ones to funding from public budgets. The differences between the European and the African countries are less essential. Also the progress of curves is very similar.

In the case of indicators of the Internet users in the EU countries shows considerable dynamism in the use of information technology. This trend is trying to zoom in the North African country. Although it does not reach such a level as the EU countries, the trend of the picture is similar.

## **Conclusion**

Although the further enlargement of the European Union in the future seems to be inevitable, it is not so clear from that analysis. It cannot be made unambiguous conclusion that on the basis of indicators of the processed in this analysis, it can be estimated for another direction of development in the enlargement of the EU.

We can suggest certain trends from the above analysis, but do not lead to the certain conclusions. The enlargement of the EU on the African continent would be possibly, however, it should not be taken only from the economic indicators which are not just about the economic power. For the estimation of countries is necessary to take into account the security criteria, which are related to economic performance, but in situation of the African countries is not the link explicit.

## **References**

- [1] *Africa-EU Strategic Partnership. The African Union Commission and the European Commission. Africa and Europe in Partnership* [online]. 2010. [cit. 2012-04-30]. Available from WWW:  
<<http://www.africa-eu-partnership.org/africa-eu-strategic-partnership>>.

- [2] AFRICAN UNION COMMISSION *African Union: United and Strong Africa. African Union* [online]. Addis Ababa: The African Union Commission, 2012. [cit. 2012-04-30]. Available from WWW: <<http://www.au.int/en/>>.
- [3] ARMSTRONG, H., TAYLOR, J. *Regional Economics and Policy*. Oxford: Blackwell Publishing, 2004. 437 p. ISBN 978-0-631-21713-4.
- [4] COLLIER, P. *The Bottom Billion. Why the Poorest Countries are Failing and what can be done about it*. Oxford, New York: Oxford University Press, 2008. 209 p. ISBN 978-0-19-537663-6.
- [5] COUNCIL OF THE EUROPEAN UNION *The Africa-European Union: Strategic Partnership* [online]. Brussels: European Communities, 2008. [cit. 2012-04-30]. 127 p. DOI 10.2860/26817, QC-30-08-446-EN-C. ISBN 978-92-8242375-2. Available from WWW: <[http://www.consilium.europa.eu/uedocs/cms\\_data/librairie/PDF/EN\\_AFRICA\\_inter08.pdf](http://www.consilium.europa.eu/uedocs/cms_data/librairie/PDF/EN_AFRICA_inter08.pdf)>.
- [6] EICHLER, J. *Mezinárodní bezpečnost v době globalizace*. Praha: Portál, 2009. 328 p. ISBN 978-80-7367-540-0.
- [7] FFP – FUND FOR PEACE. *Failed States Index: About the Failed States Index* [online]. Washington, D. C.: Fund for Peace, 2012. [cit. 2012-03-15]. Available from WWW: <<http://www.fundforpeace.org/global/?q=fsi-about>>.
- [8] KREJČÍ, O. *Mezinárodní politika*. Praha: Ekopress, 2010. 751 p. ISBN 978-808-6929-606.
- [9] PARKER, J., RATHBONE, R. *African History: A Very Short Introduction*. New York: Oxford University Press, 2007. 165 p. ISBN 978-0-19-280248-4.
- [10] AFRICAN UNION COMMISSION *South Sudan Becomes African Union's 54th Member. VOA – Voice of America. East Africa* [online]. Addis Ababa: The African Union Commission, 2012. [cit. 2012-04-30]. Available from WWW: <<http://www.voanews.com/english/news/africa/east/South-Sudan-Becomes-African-Unions-54th-Member-126320433.html>>.
- [11] WORLD BANK *The World at a Glance*. [online]. Washington, D. C.: The World Bank, 2012. [cit. 2012-02-16]. Available from WWW: <<http://data.worldbank.org/>>.
- [12] ZÁHOŘÍK, JAN. *Subsaharská Afrika a světové mocnosti v době globalizace*. Praha: Nakladatelství Lidové noviny, 2010. 179 p. ISBN 978-80-7422-021-0.

## Contact Address

### Ing. Martin Sobotka, Ph.D.

University of Pardubice, Faculty of Economics and Administration, Institute of Economic Sciences

Studentská 84, 532 10 Pardubice, Czech Republic

E-mail: [martin.sobotka@upce.cz](mailto:martin.sobotka@upce.cz)

Phone number: +420 466 036 127

**Ing. Lucie Sobotková, Ph.D.**

University of Pardubice, Faculty of Economics and Administration, Institute of Economic Sciences

Studentská 84, 532 10 Pardubice, Czech Republic

E-mail: lucie.sobotkova@upce.cz

Phone number: +420 466 036 159

**Ing. Zdeněk Řízek.**

University of Pardubice, Faculty of Economics and Administration, Institute of Economic Sciences

Studentská 84, 532 10 Pardubice, Czech Republic

E-mail: zdenek.rizek@upce.cz

Phone number: +420 466 036 477

Received: 01. 05. 2012

Reviewed: 29. 06. 2012

Approved for publication: 01. 11. 2012

# TEMPORARY EMPLOYMENT AS AN ALTERNATIVE UNEMPLOYMENT RATE REDUCING NEW EMPLOYMENT FORM ANALYSIS IN LITHUANIA AND CZECH REPUBLIC

Erika Svedaite, Teodoras Tamosiunas

**Abstract:** *The paper study identify temporary employment as an alternative unemployment rate reducing new employment form in European Union, Lithuania and Czech Republic. After the scientific literature, European Labour Force Survey (EULFS), Eurostat , document and statistical department analysis, systematization and comparison there was presented temporary employment concept and how it reduce unemployment rate, legal this atypical work form regulation. A study disclosed temporary employment indicators and how it reduce unemployment rate in Lithuania, Czech Republic and European Union. Study provides results that show temporary employment importance in labor market that reduce unemployment rate.*

**Keywords:** *Temporary employment, Temporary work agency, Temporary worker, Temporary employment contract, Temporary employment law, Unemployment rate.*

**JEL Classification:** *E2, E24.*

## Introduction

### 1 The relevance and the main issues of the research

Temporary employment is a new labor relations problems solving service in Lithuania. It allows people to work at least temporarily and find yourself losing hope in searching for a permanent job. For employers in Lithuania this new method of recruitment allows to save significant money and stay in the market during downturn.

Temporary employment is one of the measures that improve employment policies. Those services allow for passive participants easier to enter the labor market. This recruitment method is particularly relevant in addressing the unemployment rate problem.

During difficult economic and social situation in Lithuania and whole Europe countries entrepreneurs quickly began to explore new ways of saving the company money. One of them - job cuts. People on that time began to explore more diverse ways and opportunities to find the work.

**The practical research problem aspect** is associated with a temporary employment situation in Lithuania, Czech Republic and the whole European Union. It becomes an important to identify temporary employment services as a new way that reduce unemployment rate.

Temporary employment agency services significantly contribute the labor market positive improvements implementation especially with seasonal businesses and those

that flexibly respond to the effects of globalization in business. This employment form help to reduce unemployment rate in every EU country and make opportunities easier to integrate people to market trade. In addition, this service is relevant for low-skilled individuals and thereby it reduce unemployment.

**Scientific temporary work issue** in scientific level has not been widely studied. The legal aspects of this theme was highlight by Dr. T. Bagdanskis and prof. Dr. G. Dambrauskiene in scientific articles. Temporary employment services in public sector organizations are considered in E. V. Bartkus, A. Raipos and Z. Liepes articles. It discusses the nature of the outsourcing phenomenon, analyzing the scientific literature on the economic resources to temporary employment treatment. Flexible working time models are considered by S. Zickiene and A. Kovieriene research paper. Non-traditional recruitment methods including temporary employment are analysed in the collective work of Non-Standard Work and Industrial Relations. It provides examples of what recruitment methods are selected in various parts in the world.

**The research subject** – temporary agency work as an alternative unemployment rate reducing new employment form.

**The research aim** – to analyse temporary work as an alternative unemployment rate reducing new employment form in Lithuania, Czech Republic and EU.

**Research objectives:**

- After the analysis of scientific literature to explore the theoretical aspects of temporary employment.
- Define the legal regulation of temporary employment in Lithuania, Czech Republic and EU.
- To identify unemployment rate in Lithuania, Czech Republic and EU.
- Compare Lithuania and Czech Republic unemployment rate and to explore temporary work role in both countries.

**The research methods:** Scientific literature and document analysis, systematization, comparison, generalization. Empirical investigation methods: the quantitative and qualitative documents and data bases analysis, interpretation.

## **2 Theoretical aspects of temporary work**

Flexibility in the labor market is a necessary condition for competition that help address issues of unemployment, which means new jobs and the emergence forms of employment and together with temporary employment appearance, on purpose to make more efficient human resources use [15].

Temporary employment agency provide an atypical form of employment relationship. Those relationship are among three entities - employment agency, a temporary employee and company user. Temporary employment characterized by a so-called triangular or trilateral relationship between employment agencies, temporary staff and users of the company in whose favor a temporary worker performs certain tasks assigned to it. Generally regarded as temporary employment agency worker, employment agency - is an entity providing temporary workers to the firm users, and the user company – is an entity that uses temporary worker's employment [9, 7].



Temporary employment agencies services are considered of a number of authors. The first table presents scientists who examined the temporary employment agency services statements, test results and assessments of temporary employment.

**Tab. 1: Temporary employment theoretical concepts**

Mertens, A.; Mcginnity, F. (2004)	Found a connection between main three temporary work participants: the temporary work agency, working under a temporary contract staff and temporary work user. He state key factors leading temporary work existence attractiveness in employment among the users. Time and administrative cost are reducing and minimize. Human recourses recruitment process take less time using temporary agency services that allows client personnel staff divide their work time to direct functions. This author find out that using temporary agency services help companies to control the number of employees in order to contribute the companies financial resources and reduce cost
J. Arrowsmith (2009)	Temporary work agencies services are focused on temporary employment services for job seekers who are interested in short-term job offers.
A.Krisciuniene (2011)	Authors state, that people who are struggling to integrate into the labour market, students or people who have lost their job unexpectedly generally are interested in temporary work agency services.
A. Clark (2005)	Study temporary workers productivity to company. According to financial implications of increasing temporary employees and company productivity he found that temporary employment service contributes to cost reduction.
K. Obloj (2010)	Argues, that companies that are using temporary agency services can reduce costs that also reduce transmission of human resource management and rise possible job retention services.
D. A. Foote and T. B. Folta (2002)	Temporary employment services help company to avoid the unnecessary costs of human resources recruitment and permanent employment.
A. L. Kalleberg (2000)	By his research, he find out that mostly employers use temporary agency services for flexible management of existing number of employee in case when it is necessary to increase or decrease it. While for others the importance between employees it their ability to perform various tasks.
Judickiene, J. (2008)	Thought that temporary work has positive effects such as it is an opportunity to employ the unemployed market participants, but at the same time he argue that temporary employees receive lower wages than the same job working permanent company workers.
D. Jong, R. Witte (2008)	Argues that temporary agency services may become a negative factor for natural and legal persons.
R. Witte, K. Naswal (2003)	Found that temporary workers sense of job security were less committed than it was among permanent company employees.
L. Vosko (2008)	Argues that temporary worker is less subordinate for temporary services using companies than permanent workers.

*Source: The table is created based by authors' study*

In general temporary employment agencies services have main those benefits divided to three this flexible work user groups:

1. For temporary employee: gain greater career and personal development opportunities; gain valuable experience in project management; ability to

- test and apply specific skills in different organizational context; gain new skills, working experience in challenging areas.
2. For temporary employment agency: improve workers' skills; teamwork and cross functional staff's ability to exchange information; raise employee motivation and job satisfaction; extend the acquaintance; acquire a good employer reputation that takes care of community development.
  3. For using a temporary employment services company: receive the assistance required to implement the project; flexible human resources management [14].

To sum up, according to different authors statements temporary employment agency services are flexible, help to increase labour productivity; promotes competitiveness; provides temporary workers permanent jobs places and helps respond and adapt to economic cycles. It allows people to get the job pretty quickly which give them the necessary starting point for a new life. However, this also means that they are working as temporary employees and at the same time do not have the same working conditions as direct employees. Minimum wage they are getting can often be the maximum.

### **2.1. The legal regulation of temporary employment**

The appearance of temporary employment agency in Lithuanian labor market led the international companies which used this form of employment in the whole world. At the moment temporary employment services became more popular in companies due to staff shortages and in budgetary institutions.

Temporary employees in Lithuania especially young people feel more free without having to commit to work in the same job continuously. At the end of the agreed work for the duration of the work task, the company strives to offer another job. With increased labor hire, recruitment companies set up enterprises engaged in labor of temporary employment.

The second table provide the temporary employment regulation by special laws in European Union and Lithuania.

**Tab. 2: Temporary work regulatory framework**

European Union temporary work regulatory framework	Lithuanian temporary work regulatory framework
Labor Code	Lithuania Labour Code
Directive No. 2008/104/EC	Directive No. 2008/104/EC
1996 16 December European Parliament and Council Directive 96/71/EC	1996 16 December European Parliament and Council Directive 96/71/EC
1991 25 June Council Directive 91/383/EEC	1997 3 June International Labor Organization's 181 Convention
1997, Private Employment Agencies Convention	2011 1 December Temporary employment law

*Source: The table is created based by authors' study*

Following European Union and Lithuanian temporary work regulatory frameworks it could be stated that Labour code is one of the main official law that provide rules of temporary employment legal use. On the other hand, the legal and social status of temporary employment agency work in different European Union countries is not the same. Directive No. 2008/104/EC was adopted by European Parliament and Council which set temporary agency providing temporary employment services rights which was taken according to the labor markets. All necessary conditions in this document must be provided in all European Union member states which have temporary employment offering agencies.

1996 16 December European Parliament and Council Directive No. 96/71/EC regulate temporary agency work relationships among three entities: temporary employment agency, temporary employee and temporary employment company user. All member states must ensure this official document adaptation in their law and use it for right employment relationships [8].

1991 25 June Council Directive 91/383/EEC regulate temporary employment relationships in European Union countries as well. This document follow healthy and safety temporary employee work place. This directive concept is transposed into national Lithuania law [5].

1997 private employment agencies convention 1 article define temporary employment services and give the concept of private temporary employment agencies where private temporary employment agency is defined as a company or private person that has legal permit to provide temporary employment services in labor market [3].

1997 3 June international labor organization's 181 convention on private temporary employment agencies in Lithuania was ratified in 2004. After this convention in 2011 1 December in Lithuania appear temporary employment law that provides human recourses recruitment services and correct temporary employment use. The purpose of this directive is to ensure the temporary employees protection and to improve the quality of temporary employment services providing agencies [4]. Furthermore, this law introduce the principles of temporary employee working conditions.

## **2.2. Czech Republic temporary work regulatory framework**

Temporary employment law is most evident in the Czech Republic where it was put on a legal footing from October 2004. The first specific legislation for temporary employment in the Czech Republic was the Employment Act 2004. The new legislation was designed to clarify legal relationships and provide better protection for temporary employees following ratification of ILO convention no. 181 in 2001. Under the new law temporary employment may assign an employee to the same user for a maximum period of 12 consecutive calendar months, unless the employee requests a longer period or if the work being done is replacing that of an employee on maternity or family leave. The maximum total period for repeat fixed-term employment periods is set at two years [18].

In the Czech Republic the labour and social affairs ministry issues licences subject to criteria relating to age (over 23 years), residency, personal integrity, educational qualifications and experience. No financial guarantees are required, but a licence fee is charged (currently CZK 10,000 (about €350) if the business involves international placements and CZK 1,000 for activities solely carried out within the country). The labour office has the authority to perform inspections to ensure that employment regulations are enforced, although this is reportedly conducted only in response to a complaint [24].

## **3 Unemployment rate in Lithuania, Czech Republic and European countries**

According to International Confederation of Temporary Agency Work Businesses (CIETT), temporary employment agencies in the European Union currently employ over seven million workers - 1.9% of the EU working population. Temporary employment is often found out as a tool promoting flexibility in the labour market. It improves easier job searching and reduces unemployment rate [1].

The unemployment rate in the EU has been growing since September 2008. Based on Eurostat's estimations, the unemployment rate in the EU-27, seasonally adjusted, in April 2009 made up 8.6%, while in April 2008 – 6.8%. In April 2009, the highest unemployment rates were recorded in Spain (18.1%), Latvia (17.4%), Lithuania (16.8%), and Estonia (13.9%), while the lowest – in the Netherlands (3.0%), Austria (4.2%), Cyprus (5.4%), Denmark and Slovakia (5.5% in each). Unemployment has been increasing in almost all EU countries. The vastest increase in the unemployment rate from April 2008 to April 2009 was observed in Lithuania (from 4.3 to 16.8%), Latvia (from 6.1 to 17.4%) and Estonia (from 3.7 to 13.9%). In March 2009, the unemployment rate in the United States of America made up 8.9%, a year ago – 5.0% [12].

Table 3 shows unemployment rate annual year average in European Union, Czech Republic and Lithuania.

**Tab. 3: Unemployment rate (%)**

<b>GEO/TIME</b>	<b>2001</b>	<b>2002</b>	<b>2003</b>	<b>2004</b>	<b>2005</b>	<b>2006</b>	<b>2007</b>	<b>2008</b>	<b>2009</b>	<b>2010</b>
<b>EU Countries</b>	8,6	8,9	9,1	9,2	9,0	8,3	7,2	7,1	9,0	9,7
<b>Czech Republic</b>	8,0	7,3	7,8	8,3	7,9	7,2	5,3	4,4	6,7	7,3
<b>Lithuania</b>	16,5	13,5	12,5	11,4	8,3	5,6	4,3	5,8	13,7	17,8

*Source: Eurostat, 2012.*

The Czech Republic labour and social affairs ministry reported that the unemployment rate increased by 0.4% from 9.8 % in December of 2011. Employment offices registered over 500,000 job seekers last month. The highest rates of unemployment were recorded in the Northern regions of Bohemia and Moravia, reaching over 20% in some areas. The lowest unemployment is in Prague and reach 3 % [12].

Daniel Munich who is a professor at the Centre for Economic Research and Graduate Studies at Charles University and specializes in the labour market named those the main unemployment rate reasons: “The growing unemployment has at least two or three reasons. First, there is a European wide recession and one would conclude that it should impact the Czech labour market. The second impact is through the welfare system, which attracts more and more people who stay long-term unemployed collecting benefits and not being interested to work or work in the informal sector and not being taxed. So while the European recession will change the impact on the welfare system is permanent and contribute to growing unemployment of there is no change in the welfare system.” Czech Republic has about 40% of unemployed are long-term unemployed, meaning more then 12 months. While long-term unemployed are losing their skills, their work habits so it’s decreasing their productivity. And second, if these are parents it is likely that these parents transfer these habits of no work and living on welfare to their children, this is especially the case in North Bohemia and Moravia. Some kids in these families have never seen their parents working so they think this is the style of living, not to work and collect benefits [6].

According to provisional data of Statistics Lithuania, the unemployment rate in 2009 reached 13.7%, i.e. by 2.4 times more than in 2008. In 2009, increase in the male unemployment rate was more rapid than that in the female unemployment rate. In 2009, the male unemployment rate made up 17% and over the year increased 2.8 times, while the female unemployment rate made up 10.4% and over the year increased 1.9 times. In 2009, the unemployment rate in urban areas was lower than in rural areas and made up 12.6%, in rural areas – 16.5%. In 2008, the unemployment rate in urban areas made up 5.7 %, in rural areas – 6.1%, i.e. respectively 2.2 and 2.7 times less than in 2009. The highest unemployment rate was recorded in 2001 (17.4 %), while the lowest – in 2007 (4.3%) [23].

The overall unemployment rate in the EU reached 9.7% in 2010. The unemployment rate in the EU, Czech Republic and Lithuania has been growing since 2009, when economical crisis has appeared in every country labour market. In comparison to the rate during 2009, the unemployment rate rose by 0.7% points. This

is less than the steep rise from 2008 to 2009 due to the economic crisis, when the rate rose by 1.9% points between 2008 and 2009. The impact of the economic crisis on unemployment in the years from 2008 to 2010 has now completely wiped out the reduction experienced in the unemployment rate between 2004 and 2008 [12].

The unemployment rate rose in all 27 Member States between 2009 and 2010, apart from Germany, Luxembourg, Malta and Austria. The biggest decrease was recorded in Germany, where the unemployment rate dropped by 0.7% points. Belgium, France, Romania, Finland, Sweden and the UK also performed well, showing only moderate increases (below 0.5% points) between 2009 and 2010. While Estonia and Lithuania were among the countries with the highest increases, they recorded decreases in unemployment in the second half of 2010. High increases were also perceived in Greece, Spain and Slovakia. Spain remained the country with the highest overall unemployment rate in 2010, at 20.1%. The dispersion of unemployment across the EU continued to increase during 2010 [12].

Among the Member States, the lowest unemployment rates were recorded in Austria (4.1%), Luxembourg (4.7%) and the Netherlands (4.8%), and the highest rates in Spain (22.8%), Greece (18.3% in August) and Latvia (16.2% in the second quarter of 2011). Compared with a year ago, the unemployment rate fell in twelve Member States and increased in fifteen. The largest falls were observed in Estonia (16.1% to 11.3% between the third quarters of 2010 and 2011), Lithuania (18.3% to 15.0% between the third quarters of 2010 and 2011) and Latvia (19.3% to 16.2% between the second quarters of 2010 and 2011). The highest increases were registered in Greece (12.9% to 18.3% between August 2010 and August 2011), Spain (20.5% to 22.8%) and Cyprus (6.0% to 8.2%) [11].

International human resource management experts over the years have an active discussion and do not access to the general conclusion of what is the reasons of temporary employment development. In some places (UK, Ireland) temporary agency services became popular in the labor market during periods when passive participants were trying to enter the labor market and reduce unemployment rate with more flexible labor relations rules [2].

#### **4 The research method**

In order to prepare this research data was drawn from European Labour Force Survey (EULFS), Eurostat and statistical department. Those databases provide standardised, statistical information on individuals compiled from national Labour Force Surveys. It contains information regarding labour force participation, employment characteristics, gender, age, education and occupational status among others. The survey was designed to represent the working-age population in Europe and in each country. Thus provides database of employment issues in Europe countries.

#### **5 Analysis of the findings**

According to M. F. Corbett (2004) temporary employment agency services in other words could be named as external outsourcing were started to use since the 1970s in America. In economic theory this process is defined as the use of external resources

like a worthy service. That is way of business that is treated as a resource rental or lease services [4].

American management association showed that from 1995 more than half of the production company gave some part of their manufacturing process to temporary agency employees. Recently, a temporary employment covers a wide range of activities from which the main distinction is between these three: information technology, business process management and production services [17].

There is a lack of statistical sources dealing with the concept of temporary employment rate indicators in European Union. For instance, temporary employment indicators could be found in several national labour force statistics. However, this employment rate reducing work form data availability especially statistical information and researches on working conditions in European countries is very limited. This raises difficulties in data collection and temporary work monitoring developments analysis in labour market.

According to Eurostat statistical information the number of temporary agency workers since 1999 has increased worldwide from 5,2 million full time equivalents to nearly 9 million in 2009. In the last ten years the number of temporary employment agency workers in Europe has increased too. The fourth table shows the number of thousands of temporary employees in Europe, Lithuania and the Czech Republic.

**Tab. 4: umber of temporal workers**

Number of temporary agency workers (thousands)											
Country / year	1999	2000	2001	2002	2003	2004	2005	2006	2007	2008	2009
EU	2,12	2,62	2,62	2,60	2,73	2,95	3,12	3,46	3,91	3,88	3,21
Lithuania	-	-	-	-	-	-	-	-	-	-	1
Czech Republic	-	-	-	-	-	-	-	-	-	35	36

*Source: OECD's Library, (2012).*

The temporary workers data of Lithuania are not provided by Lithuanian statistic department and statistics department of Eurostat provides data for the year 2009 only. Number of temporary employee in the Czech Republic from 2008 to 2009 has increased by one thousand workers. The number of temporary employee in the same year in the European Union countries fell by 671 employees. Indicator drop down at that time as result because of economic crisis in the European Union. The evolution of the number of temporary employees in European Union during past years display strong inverse correlation with the year on year on reducing unemployment rate in all EU 27 countries. This set a confirmation as temporary agency services become a leading business indicator in European Union that positively effect labor market.

According to quarterly labour force sample survey in Czech Republic, permanant worker is name persons whose main job is a permanant job or with a work contract of

unlimited duration. Temporary worker: workers whose main job is a: fixed-term contract; interim work through a temporary work agency; apprentices and trainees; probationary period; an occasional, casual or seasonal worker; carries out community work as an unemployed; or has a contract for a specific task. Czech Republic has 215 operating temporary employment agencies while Lithuania has near 15.

Table 5 presents the percentage of temporary employees in EU, Lithuania and Czech Republic.

**Tab. 5: Percentage of temporal workers**

<b>Temporary employees as a percentage of the total number of employees (%)</b>											
<b>Country / year</b>	2000	2001	2002	2003	2004	2005	2006	2007	2008	2009	2010
<b>EU</b>	13,4	13,1	13,1	13,3	13,4	14,4	15,0	15,0	14,6	14,0	14,4
<b>Lithuania</b>	-	-	-	-	-	-	-	-	-	1,8	2,9
<b>Czech Republic</b>	9,3	9,0	8,8	9,9	9,5	8,6	8,7	8,6	8,0	8,5	8,9

*Source: OECD's Library, (2012).*

Table 6 provides the number of temporary employees as a percentage (%) of the total number of employees. This table does not provide sufficient data on temporary employment situation in Lithuania, as this information is not delivered by statistics department. Comparing the 2009 and 2010, the amount of temporary employees in Lithuania and in the Czech Republic shows that in Lithuania this index increased 1.1 percent and 0.4% in the Czech Republic. Meanwhile, the Czech Republic temporary employees accounted for nearly 10 percent of all state employees. In European Union this index was nearly 15 percent which indicates that temporary agency services are quite relevant for companies. Thus, the temporary employment contributes to reducing the unemployment rate in Lithuania and the Czech Republic and all European Union countries.

## **Conclusions**

Temporary employment is one of the consequences of the division of labor. Division of labor is as a phenomenon that allows businesses to directly engage only selected activities and all other ancillary support or maintenance (recruitment, personnel records, etc.) and other activities deliver to companies that specialize on it and can all do better and for lower cost. What is more it allow the company save money and additional costs in employee time for it recruitment procedures, job safety briefing, pay staff salaries, taxes.

The main temporary employment influencing factors are: lack of labor supply, reducing unemployment, reducing the possibility of time in searching for employees, the company financial constraints, need quickly find a worker for jobs, free movement of workers.



European Confederation of Private Employment Agencies (Eurociett) summarizes the twenty-seven European countries statistics and found that the increase in temporary workers working hours reduced unemployment rate and at the same time increase the country's GDP. Temporary employment is not only to reduce unemployment, but also reduces illegal activity and increase employment in general. It allows a greater range of employees to social security and attracts foreign investment.

## Discussion

Flexible work forms as the subject of Lithuanian higher education were analyzed only fragmentary. Separate flexible work organization principles were analyzed by dr. B. Gruevski, prof. dr. G. Dambrauskiene. But temporary employment in higher education has not been studied scientifically. The present analysis could be used for further research. What is more temporary agency service in Lithuania comparing with this service experience in foreign countries is a new flexible form of employment, especially from 2011 year December when temporary employment law was accepted.

Article provides temporary employment legal conditions, situation analysis and how it reflect labor market unemployment rate. This research leads to understand that temporary employment become necessity of labor market that helps to reduce unemployment rate. In the future well presented temporary employment services can strongly decrease unemployment rate but at the same time raise the lack of permanent job places.

## References

- [1] ARROWSMITH, J. (2009). *Temporary agency work and collective bargaining in the EU*. European foundation for the improvement of living and working conditions. Available online at:  
[http://www.eurofound.europa.eu/eiro/studies/tn0807019s/tn0807019s\\_7.htm](http://www.eurofound.europa.eu/eiro/studies/tn0807019s/tn0807019s_7.htm)
- [2] Association of Management Professionals (2007-08). *Temporary employment - the benefits to business and the employee*. Business News. Vilnius, p. 6-18.
- [3] Convention on private employment agencies. No convention. 181st State news. 2004, No. 40. Available online at:  
<http://www.litlex.lt/scripts/sarasas2.dll?Tekstas=1&Id=71600>.
- [4] CORBETT, M. F. (2004). *Outsourcing revolution*. Chicago: Dearborn trade publishing Kaplan Professional company.
- [5] Council Directive 91/383/EEC of 25 June 1991 supplementing the measures to encourage improvements in the safety and health at work of workers with a fixed- duration employment relationship or a temporary employment relationship, (1991). Official Journal L 206 , 29/07/1991 P. 0019 – 0021. Available online at: <http://eur-lex.europa.eu/LexUriServ/LexUriServ.do?uri=CELEX:31991L0383:en:HTML>
- [6] MUNICH, D. (2007). *Unemployment in East and West Europe*. Ross School of Business Paper No. 1076. Available online at:  
[http://papers.ssrn.com/sol3/papers.cfm?abstract\\_id=986633](http://papers.ssrn.com/sol3/papers.cfm?abstract_id=986633).

- [7] Department for business innovation and skills, (2011). *Agency workers regulations*. Guidance.
- [8] Directive 96/71/EC of the European Parliament and of the Council of 16 December 1996 concerning the posting of workers in the framework of the provision of services, (1997). Official Journal L 018 , 21/01/1997 P. 0001 – 0006. Available online at: <http://eur-lex.europa.eu/LexUriServ/LexUriServ.do?uri=CELEX:31996L0071:EN:HTML>
- [9] Eurociett, European Confederation of private Employment Agencies (2007). *More work opportunities for more people*. Strategic report for discussion. Brussels. Available online at: [http://www.ciett.org/fileadmin/templates/ciett/docs/20071126\\_strategic\\_report.pdf](http://www.ciett.org/fileadmin/templates/ciett/docs/20071126_strategic_report.pdf).
- [10] Eurociett, European Confederation of private Employment Agencies (2011). Evolution of number of hours worked by agency workers in Europe. Available online at: [http://www.eurociett.eu/fileadmin/templates/eurociett/docs/stats/Eurociett\\_agency\\_work\\_business\\_indicator\\_-\\_Apr\\_2011\\_final.pdf](http://www.eurociett.eu/fileadmin/templates/eurociett/docs/stats/Eurociett_agency_work_business_indicator_-_Apr_2011_final.pdf).
- [11] European Commission, (2011). *Employment, social affairs and inclusion*. Available online at: [https://ec.europa.eu/employment\\_social/anticipedia/xwiki/bin/view/Blog/Euro+area+unemployment+rate+at+103%25](https://ec.europa.eu/employment_social/anticipedia/xwiki/bin/view/Blog/Euro+area+unemployment+rate+at+103%25)
- [12] Eurostat, (2012). *Unemployment rate, annual average, by sex and age groups*.- Available online at: [http://appsso.eurostat.ec.europa.eu/nui/show.do?dataset=une\\_rt\\_a&lang=en](http://appsso.eurostat.ec.europa.eu/nui/show.do?dataset=une_rt_a&lang=en)
- [13] FOOTE, D. A.; FOLTA, T. B. (2002). *Temporary workers as real options*. Human Resource Management Review, 12: 4, 579-597.
- [14] GAGLIARDUCCI, S. (2005). *Intermittence in temporary employment: Italy vs. UK, 1990-1997*. European University Institute.
- [15] GIMENO, D., BENAVIDES, F. G. (2002). *European Foundation for the Improvement of Living and Working Conditions*. Available online at: <http://www.eurofound.europa.eu/pubdocs/2002/21/en/1/ef0221en.pdf>.
- [16] International Labour Organization, (2009). ILO report says temporary workers among the worst hit by the economic crisis, urges balances between flexible labour markets and workers protection. Available online at: [http://www.ilocarib.org.tt/portal/index.php?option=com\\_content&task=view&id=1310&Itemid=368](http://www.ilocarib.org.tt/portal/index.php?option=com_content&task=view&id=1310&Itemid=368).
- [17] HENDRY, J. (1995). *Culture, community and networks: the hidden cost of outsourcing*. European management journal, Vol. 13, No 2, 193 – 200.
- [18] JAROSLAV, H. (2009). *Czech Republic: Flexicurity and industrial relations*. Research Institute for Labour and Social Affairs. Available online at: <http://www.eurofound.europa.eu/eiro/studies/tn0803038s/cz0803039q.htm>
- [19] JONG, D., WITTE, R. (2008). *Literature review of theory and research on the psychological impact of temporary employment: Towards a conceptual model*.

- International Journal of Management Reviews. Volume 10, Issue 1, pages 25–51, March. Available online at:  
<http://onlinelibrary.wiley.com/doi/10.1111/j.1468-2370.2007.00221.x/abstract>.
- [20] JUDICKIENE, J. (2008). *Hire employees on track*. Business News No. 29, p. 12. Available online at:  
<http://archyvas.vz.lt/news.php?id=933385&strid=1002&rs=0&ss=&y=2008%2002%2012>.
- [21] KALLENBERG, L. (2000). *Nonstandart employment relations: part-time, temporary and contract work*. Annu Rev. Social, 26:341-65. Carolina.
- [22] KRISCIUNIENE, A. (2011). *Workers' rent - undiscovered opportunities for builders*. Available online at:  
[http://www.infostatyba.lt/lt/statyba/darbuotoju\\_nuoma\\_+statybinese\\_+imonese/?page\\_id=399&subpage\\_id=425](http://www.infostatyba.lt/lt/statyba/darbuotoju_nuoma_+statybinese_+imonese/?page_id=399&subpage_id=425).
- [23] Lithuania Statistics department - Unemployment rate, (2010). Available online at: <http://www.stat.gov.lt/en/news/view/?id=8680&PHPSESSID=.>
- [24] MARCELA, K. (2002). *National Labour Law Profile: The Czech Republic*. Available online at: [http://www.ilo.org/ifpdial/information-resources/national-labour-law-profiles/WCMS\\_158893/lang--en/index.htm](http://www.ilo.org/ifpdial/information-resources/national-labour-law-profiles/WCMS_158893/lang--en/index.htm)
- [25] MERTENS, A., MCGINNITY, F. (2004). *Wages and Wage Growth of Fixed-Term Workers in East and West Germany*. Applied Economics Quarterly, No. 2
- [26] OBLOJ, K. (2010). *Dominant Logic and Entrepreneurial Firms' Performance in a Transition Economy*. Entrepreneurship Theory and Practice Volume 34, Issue 1, pages 151–170, January. Available online at:  
<http://onlinelibrary.wiley.com/doi/10.1111/j.1540-6520.2009.00367.x/full>.
- [27] OECD's iLibrary, (2012). *Incidence of permanent employment*. Available online at: [http://stats.oecd.org/Index.aspx?DatasetCode=TEMP\\_I](http://stats.oecd.org/Index.aspx?DatasetCode=TEMP_I)
- [28] The employment and unemployment rates in the Czech Republic and in other Member States of the European Union according to results of the Labour Force Sample Survey, 2011. Available online at:  
<http://www.czso.cz/csu/csu.nsf/engineformace/azam110411analyza11.doc>).
- [29] VOSKO, L. (2008). *Temporary Work in Transnational Labour Regulation*.
- [30] Working codec. Lithuanian Labour Code. Second Edition 2005-09-05, Ministry of Justice. Legal Information Centre. Approved in 2002 4 June Law no. IX-926, entered into force in 2003 January 1st. Vilnius, 2005.

## Contact address

### Erika Svedaite

JSC „Darbinteria Lt“, Tilzes str. 124. Siauliai, Lithuania  
 Siauliai University, Vilniaus str. 88, Siauliai, Lithuania

E-mai: erika.svedaite@gmail.com

Phone number: +370 674 90573

**Teodoras Tamosiunas**

Siauliai University

Vilniaus str. 88, Siauliai, Lithuania

E-mail: teodoras@cr.su.lt

Phone number: +370 685 95804

Received: 21. 03. 2012

Reviewed: 04. 06. 2012

Approved for publication: 01. 11. 2012

# THE CYCLICALITY OF GOVERNMENT EXPENDITURE AND WAGNER'S LAW – CASE OF CZECH REPUBLIC, SLOVAKIA, HUNGARY, BULGARIA AND ROMANIA

Irena Szarowska

**Abstract:** *The importance of government expenditure management has increased during the last years. This paper provides empirical evidence on the cyclicality and the relationship between government expenditure and output in five European Union members in a period 1995–2009. We use Johansen cointegration test and the error correction model and analyze annual data on government expenditure in compliance with the COFOG international standard. The results confirm that the government expenditure functions are procyclical in most countries (91% cases in the sample). Output and government expenditure are cointegrated at least for four from ten expenditure functions in every country (four in the Czech Republic and Hungary, five in Bulgaria, seven in Slovakia and eight in Romania) and it implies a long-term relationship between government expenditure and output. Average value of long-run elasticity coefficients is 1.72 for all expenditure functions, 1.16 for total government expenditure. Conclusions about the short-run relationship between expenditure and output are not unambiguous due to a relatively low statistical significance. However, the coefficient values (average is 3.14) confirm the voracity hypothesis, as they suggest that in response to a given shock to real GDP, government expenditure will rise by even more in percentage points.*

**Keywords:** *Government Expenditure, Cyclicality, Voracity Effect, Long-Run Elasticity, Short-Run Elasticity.*

**JEL Classification:** *C32, H50, E62.*

## Introduction

The importance of government expenditure management has increased during the last years. Government expenditure and factors of their growth are a serious problem of many countries. As [16] mention, the economic theory provides two main categories of arguments that explain the public sector size in time and among countries. The first category has as starting point the Wagner law, according to which the elasticity of government expenditure compared to GDP is greater than one. As countries become more developed, the demand for public goods raises and is consistent with the increasing ability to collect the necessary funds. On the other hand, the “Baumol cost disease”, explains that the percentage of government expenditure increases because the raise of public servants’ salaries is higher than their productivity, while the price related to public services demand is relatively non)elastic. The second category of arguments is political. For election purposes, the fiscal policy, especially those concerning the government expenditure, tends to be inconsistent in time and focuses on greater deficits and greater public sectors.

We can find a view that government expenditure should act as a stabilizing force and move in a countercyclical direction (procyclical fiscal policy is conversely policy expansionary in booms and contractionary in recessions). Contrary to the theory (it implies that government expenditure is countercyclical), many of empirical studies found evidence that government expenditure is procyclical. See [11], [13], [3], [18], [10], [7] or [19] for more details. [20] show that fiscal procyclicality is evident in a much wider sample of countries. Analysis of [14] finds procyclicality in a single-country time series study of Irish fiscal policy. [15] also shows that the level of cyclicity varies across expenditure categories and across OECD countries. [1] test differences in the cyclicity of government expenditure across functional categories. Their evidence from 20 OECD countries suggests that procyclicality is more likely in smaller functional budgets, but capital expenditure is more likely to be procyclical for the larger expenditure categories. Many of researches as [8], [9] focused on Latin America. On the one hand, [6] shows in his research that expenditure is countercyclical. However, other papers show no discernible pattern. [5] document for G7 countries, the correlation between government consumption and output indeed appears to show no pattern and be clustered around zero. The differences in these results depend on the components of expenditure being measured. Government transfers and subsidies are found to have become substantially more countercyclical.

## **1 Statement of a problem**

As it was already mentioned, economic performance is greatly influenced by the level and the structure of government expenditure. It is not only a potential automatic stabilizer, but it is also a tool of political actions. In fact, development of government expenditure is often associated with Wagner 's law and voracity effect. Wagner's law states that government activity increases as economies grow, with the pace of increase being different for different branches of government. Voracity effect occurs if a positive shock to income leads to a more than proportional increase in public expenditure, even if the shock is expected to be temporary. The voracity is usually attributed to weak institutions and ethnic fractionalization, manifested in the presence of multiple interest groups seeking to secure a greater share of national wealth by demanding larger public expenditure on their behalf. The existing literature testing Wagner's law varies considerably in terms of the dependent and independent variables chosen to "test" the law. [21] originally proposed that as industrialization or social progress proceeded, public sectors would grow in relative importance. In practice, researchers use different measures of national income as a measure of this social progress. [17] point out on the fact that there are at least 14 different measures of government expenditure that have been used in the literature, and at least 13 different measures of output, including output per capita. In this paper we adopt the simplest formulation of Wagner's law by focusing on the relationship between aggregate economic activity and government expenditure in compliance with the COFOG international standard.

Most studies analyzing the cyclicity of government expenditure and output have used a panel data methodology that has not fully exploited the time-series properties of the data. On the other hand, studies testing for a long-run relationship, such as Wagner's law, have ignored the short-term aspects of this relationship. In the literature

on cyclicity, many studies use panel data models that are not well suited to exploring short-term versus long-term relationships. We exploit both the time-series and cross-sectional aspects using an error-correction framework.

The aim of the paper is to provide direct empirical evidence on cyclicity and the short-term and long-term relationship between government expenditure and output in five selected European countries. Although the theory implies that government expenditure is countercyclical, recent evidence suggests that it is procyclical. Previously published studies are weakly supported by the data particularly in emerging and post-transition economies in which results can vary.

We follow [2] and apply Johansen cointegration test and the error correction model on annual data of GDP and government expenditure the period 1995–2009 from Eurostat. The article is organized as follows. In the next section, we describe the dataset and empirical techniques used. Then, we present the results of government expenditure cyclicity and long-run and short-run relationship between output and government expenditure. We conclude with a summary of key findings.

## 2 Methods

The dataset consists of annual data on GDP and government expenditure in compliance with the COFOG international standard during the period 1995–2009. It is not possible to use higher frequently time series data as COFOG classification analyzes and reports only annual data. The countries included in the analysis are Bulgaria, Czech Republic, Hungary, Romania and Slovakia. The series for GDP and total government expenditure and its subcomponent are adjusted at constant prices. We used the same methodology as [2], but we applied it newly on functional classification of government expenditure in selected EU countries. In line with [2], we investigated fiscal and output co-movements by the approach proposed by [15]. We estimated the elasticity of government expenditure with respect to output, based on country-by-country time-series regressions. Next we used an error-correction approach, which allows us to distinguish between the short-term effect of output on government expenditure and any longer-term effect between these two variables. Most of the results were calculated in econometric program Eviews 7.

Many studies point out that using non-stationary macroeconomic variable in time series analysis causes superiority problems in regression. Thus, a unit root test should precede any empirical study employing such variables. We decided to make the decision on the existence of a unit root through Augmented Dickey–Fuller test (ADF test). The equation (1) is formulated for the stationary testing.

$$\Delta x_t = \delta_0 + \delta_1 t + \delta_2 x_{t-1} + \sum_{i=1}^k \alpha_i \Delta x_{t-i} + u_t \quad (1)$$

ADF test is used to determine a unit root  $x_t$  at all variables in the time  $t$ . Variable  $\Delta x_{t-i}$  expresses the lagged first difference and  $u_t$  estimate autocorrelation error. Coefficients  $\delta_0$ ,  $\delta_1$ ,  $\delta_2$  and  $\alpha_i$  are estimated. Zero and the alternative hypothesis for the existence of a unit root in the  $x_t$  variable are specified in (2).

$$H_0: \delta_2 = 0, H_\varepsilon: \delta_2 < 0 \quad (2)$$

The result of ADF test, which confirms the stationary of all time series on the first difference, is available on request. Testing the stationary is the essential assumption for implementation of cointegration approach. It is necessary to confirm that time series are non-stationary at level data but stationary at first difference.

We suppose there is a steady-state relationship between government expenditure and output given by (3).

$$G = AY^\delta \quad (3)$$

$G$  represents government expenditure,  $Y$  means output and Eq. (3) can also be written in linear form:

$$\log G = a + \delta \log Y, \quad a = \log A \quad (4)$$

If the adjustment of expenditure  $G$  to its steady-state  $\bar{G}$  is gradual, then the level of expenditure will respond to transitory changes in output, and  $G$  will move gradually toward its steady-state, or equilibrium level. To capture this gradual move, we specify a general autoregressive distributed lag specification for expenditure category  $i$  in period  $t$ :

$$\log G_{it} = \mu + \alpha \log G_{it-1} + \beta_0 \log Y_t + \beta_1 \log Y_{t-1} + \varepsilon_t, \quad |\alpha| < 1 \quad (5)$$

We can solve for the static, steady-state equilibrium by assuming that output is at its steady-state level  $\bar{Y}$  and ignoring the error term:

$$\log \bar{G} = \frac{\mu}{1-\alpha} + \frac{\beta_0 + \beta_1}{1-\alpha} \log \bar{Y}, \quad \delta = 1 - \alpha \quad (6)$$

More generally, we could allow output to grow at rate  $g$ . In this case, the only difference is that the constant term becomes  $\frac{\mu + (\beta_0 - \delta)g}{1-\alpha}$ , which depends on  $g$ . To reflect the steady state, (5) can be rearranged as the error correction model (7).

$$\log G_{it} = \mu + \beta_0 \log Y_t + \gamma (\log G_{it-1} - \delta \log Y_{t-1}) + \varepsilon_t \quad (7)$$

In (7), we can interpret  $\beta_0 \log Y_t$  as the short-term impact of output on expenditure and  $\beta_0$  as the short-run elasticity of government expenditure with respect to output. The error correction term  $\gamma (\log G_{it-1} - \delta \log Y_{t-1})$  captures deviations from the steady-state, or long-run equilibrium, where  $\delta$  is the long-run elasticity of government expenditure with respect to output, and  $\gamma$  is the rate at which government expenditure adjusts to past disequilibrium.  $\mu$  is constants of the model,  $\varepsilon_t$  means residual component of long-term relationship.

Moreover, (7) can be rewritten as (8) and then used to test if there is a long-run relationship between government expenditure and output. In particular, following [4], if  $\gamma$  is significantly different from zero in (8), then output and government expenditure are cointegrated.

$$\log G_{it} = \mu + \beta_0 \log Y_t + \gamma \log G_{it-1} - \phi \log Y_{t-1} + \varepsilon_t \quad (8)$$

where  $\phi = \gamma\delta$ . The above derivation makes clear the underlying assumption that there is a elasticity relationship between output and expenditure, while the transitory deviations are random.



### 3 Problem solving and discussion

Government expenditure can help in overcoming the inefficiencies of the market system in the allocation of economic resources. It also can help in smoothing out cyclical fluctuations in the economy and influences a level of employment and price stability. Thus, government expenditure plays a crucial role in the economic growth of a country. We used government expenditure in compliance with the COFOG international standard (Classification of the Functions of Government) in our analysis. Total government expenditure is divided into 10 basic divisions:

- G10: General public services
- G20: Defense
- G30: Public order and safety
- G40: Economic affairs
- G50: Environment protection
- G60: Housing and community amenities
- G70: Health
- G80: Recreation; culture and religion
- G90: Education
- G100: Social protection

#### 3.1 The structure of government expenditure

Firstly we analyzed the structure of government expenditure in a period 1995–2009. Results in Table 1 show the average share of government expenditure by functions, the average on total expenditure and the share of total government expenditure on GDP in each country during the analyzed period. Table 1 also presents the average of variables in all countries. Data confirm significant differences between countries and expenditure functions as well.

**Tab. 1: Government expenditure - COFOG classification (in % of total G)**

Country	G10	G20	G30	G40	G50	G60	G70	G80	G90	G100	G as % GDP
CZ	10.2%	3.4%	5.1%	19.3%	2.3%	2.7%	14.7%	2.7%	10.2%	29.4%	44.7%
HU	21.1%	2.4%	4.0%	12.3%	1.4%	2.0%	10.5%	3.1%	10.8%	32.5%	49.9%
SK	14.4%	4.6%	5.9%	15.3%	1.9%	2.2%	13.4%	2.4%	8.9%	30.9%	43.3%
BG	17.5%	6.0%	6.8%	11.5%	2.6%	1.8%	10.9%	2.0%	10.4%	30.7%	39.2%
RO	14.6%	5.8%	4.9%	17.0%	0.7%	4.4%	9.3%	2.4%	10.3%	30.6%	36.1%
Average	15.5%	4.4%	5.3%	15.1%	1.8%	2.6%	11.8%	2.5%	10.1%	30.8%	42.7%

*Source: Authors' calculations based on data from Eurostat*

Five expenditure functions, on average, account for more than 83% of the total expenditure: Social protection, Economic affairs, Health, General public services and Education. The Social protection expenditure (G100) is the highest expenditure function in every country and it takes nearly the third of all government expenditure. It contains, for example, expenditure on sickness and disability, old age, survivors,

family and children, unemployment, housing, social exclusion and R&D social protection.

The value of General public services (G10) and Economics affairs (G40) expenditure are in average very similar (15.1% resp. 15.5%), but the share differs in each country. The highest value of G10 is in Hungary, it is due to a higher expenditure on public debt services then in other countries. The value of total government expenditure is the smallest in Romania (36.1% GDP), the highest in Hungary (49.9% GDP), and the average of all countries is 42.7% GDP, that expresses significant differences in size and importance of public sector in the sample of countries.

### 3.2 The cyclicity of government expenditure

As was already noted, government expenditure is a possible automatic stabilizer. The cyclicity of government expenditure is typically defined in terms of how expenditure moves with the output gap. If government expenditure increases when there is a positive output gap (i.e. output is below its potential), then expenditure is countercyclical. If potential output were observable or easy to estimate, one could define counter-cyclicity as above-average expenditure to output ratio whenever output was below its potential. As [2] mention, measuring potential output is difficult. As a consequence, it is not easy to discuss business cycles or cyclicity per se. Therefore we focus on co-movements of government expenditure and output as a proxy for cyclicity.

**Tab. 2: The value of adjustment coefficient  $\gamma$**

	G total	G10	G20	G30	G40	G50	G60	G70	G80	G90	G100
CR	0.03 (0.03)	-0.14 (0.32)	-0.37 (0.62)	-1.14* (0.36)	-0.41 (0.25)	-0.45* (0.16)	-0.85* (0.49)	-0.35 (0.33)	-0.80* (0.27)	-0.22 (0.27)	-0.19 (0.21)
HU	-0.63 (0.45)	-0.15 (0.09)	0.27 (0.70)	0.45 (0.28)	-1.70* (0.46)	- 1.21** (0.26)	-0.16* (0.08)	-0.12 (0.36)	-0.33 (0.195)	0.30* (0.32)	-0.36 (0.25)
SK	-0.90* (0.40)	- 2.04** (0.44)	-1.21* (0.57)	-0.29 (0.53)	-0.03 (0.37)	-1.29* (0.45)	- 1.67** (0.24)	- 1.09** (0.42)	-1.05* (0.31)	0.03 (0.17)	- 1.33** (0.27)
BG	- 2.72** (0.48)	-1.00 (0.56)	0.04 (0.04)	0.31 (0.36)	-2.00* (0.76)	-1.15* (0.58)	-1.20* (0.37)	-0.06 (0.34)	-2.22* (0.64)	-0.52 (0.42)	-0.52* (0.27)
RO	-0.16 (0.20)	-0.56* (0.20)	- 0.85** (0.17)	-1.27* (0.61)	-1.27* (0.35)	- 1.38** (0.15)	-0.46* (0.23)	-0.12 (0.13)	- 1.73** (0.27)	-1.35 (0.84)	-0.05* (0.02)
Average	1.81	1.30	1.03	0.91	1.66	1.09	0.87	1.09	1.45	0.30	0.63
Share significant	40%	40%	40%	60%	60%	100%	100%	20%	80%	20%	60%

Source: Authors' calculations

Note: Symbols \*and \*\* and denote significance at the 1% and 5% level, standard deviation are in parenthesis. Average means the average absolute values of significant coefficients only. Share significant means share of significant cases.

Table 2 reports the estimates of the adjustment coefficient  $\gamma$  from equation (7), which is estimated by OLS with a correction for an autoregressive error term.  $\gamma$  is the rate at which government expenditure adjusts to past disequilibrium. In cases where  $\gamma$

is significant, we can conclude there is a cointegrating relationship between government expenditure and output. The results indicate significant difference across expenditure functions. There is a long-term relationship between total government expenditure and output consistent with Wagner's law, the share of significant results is 58% for all categories in all countries. Although the error correction term is not significant for all expenditure functions in any country of the sample, all countries have a significant error correction term for at least four of the expenditure functions (four in the Czech Republic and Hungary, five in Bulgaria, seven in Slovakia and eight in Romania). Moreover, the error correction term for Environment protection (G50) and Housing and community amenities (G60) are significant in all countries. As expected, the adjustment coefficients are mostly negative, indicating dynamic stability. The implication of a significant error correction term is that there is in fact a long-term relationship between government expenditure and output. But it is suitable to point out that the existence of cointegration does not imply causality, which is consistent with Wagner's view that there is not necessarily a cause and effect relationship between economic development and government activity.

**Tab. 3: The long-run elasticity coefficient  $\delta$**

	G total	G10	G20	G30	G40	G50	G60	G70	G80	G90	G100
CR	1.62** (0.10)	1.54** (0.26)		0.50** (0.07)	-0.46* (0.16)		2.01* (0.53)	1.94** (0.15)	1.80** (0.21)	1.62** (0.24)	1.36** (0.19)
HU	1.06** (0.05)	1.33* (0.42)	1.79** (0.08)	1.92** (0.14)	0.91** (0.13)	1.05** (0.22)	3.06* (1.19)	1.31** (0.11)	1.85** (0.21)	1.65** (0.10)	1.60** (0.18)
SK	0.46** (0.10)	0.32* (0.11)	-0.21* (0.08)		-1.27* (0.39)		0.09* (0.12)	1.20** (0.07)	0.52* (0.23)		0.54** (0.06)
BG	0.86** (0.02)		7.27** (1.19)	2.07** (0.31)	1.49** (0.14)		4.37** (0.29)	2.95** (0.62)	0.99** (0.08)	1.33** (0.08)	0.61** (0.04)
RO	1.84** (0.31)		-1.49* (0.70)	1.23** (0.28)	2.14** (0.26)	1.88* (0.49)		3.02* (1.28)	2.84** (0.24)	1.45** (0.12)	11.99* * (2.36)
Average	1.16	1.06	2.69	1.43	1.25	1.47	2.38	2.08	1.60	1.51	3.22
Share significant	100%	60%	80%	80%	100%	40%	80%	100%	100%	80%	100%

Note: Symbols \*and \*\* and denote significance at the 1% and 5% level, standard deviation are in parenthesis. Average means the average absolute values of significant coefficients only. Share significant means share of significant cases

Source: Authors' calculations

Table 3 summarizes the results about the long- run elasticity of expenditure with respect to output. It contains only significant coefficients; the long-run elasticity coefficient  $\delta$  is significant in 84% cases. A positive value of  $\delta$  is consistent with a wider interpretation of Wagner's law, as it implies that government expenditure rises with national income. If  $\delta$  is higher than one then this would be consistent with a narrow interpretation of Wagner's law, where government expenditure rises faster than national income.

The long-term elasticity of government expenditure and output  $\delta$  is positive (in 91% of cases), and it is the highest for Defense expenditure (G20) due to the extremely high  $\delta$  coefficient in Bulgaria (it greatly increased the average). Moreover,  $\delta$  is for total

expenditure larger than one (1.16), average value is 1.72 for all expenditure functions. It is consistent with the narrow interpretation of Wagner's law and indicating that in the long-term, the public sector is increasing in relative importance. The coefficient for long-run elasticity was significant in all countries for total expenditure, Economic affairs (G40), Health (G70), Recreation, culture and religion (G80) and Social protection (G100). This is important as these expenditure functions include in average 60% of total government expenditure. The average long-run elasticity coefficient  $\delta$  is not lower than one in any case; it means that each expenditure function rises faster than national income.

**Tab. 4: The short-run elasticity coefficient  $\beta$**

	G total	G10	G20	G30	G40	G50	G60	G70	G80	G90	G100
CR	0.53 (0.51)	-0.28 (1.09)	-0.94 (1.59)	1.41* (0.66)	2.34* (1.28)	5.45** (2.16)	0.81* (3.57)	0.06 (1.05)	-0.34 (1.24)	0.31 (0.84)	0.09 (0.66)
HU	1.17 (1.20)	0.31* (1.03)	3.99 (3.64)	1.13 (1.78)	2.62 (2.57)	0.09* (2.68)	0.48* (2.35)	1.12 (2.01)	4.96 (2.07)	1.38 (1.71)	1.26 (0.84)
SK	-0.64 (0.92)	7.33** (1.18)	1.58 (1.19)	2.3 (1.48)	3.25 (2.58)	2.45 (2.18)	0.22 (1.18)	2.58* (1.38)	1.37 (1.46)	0.18 (0.42)	1.65* (0.56)
BG	-2.39* (-0.75)	-5.44 (6.54)	3.71 (4.82)	-1.36 (2.13)	1.65 (3.25)	3.61 (5.15)	-6.58 (4.58)	-9.15 (5.70)	-0.15 (2.36)	-1.74 (2.36)	0.03 (0.69)
RO	-0.47 (0.64)	-2.39* (-1.12)	7.65** (-1.56)	5.7 (3.73)	-1.923* (-1.05)	12.68** (-1.53)	1.49 (0.96)	-1.51* (-0.81)	-7.63** (-1.60)	-0.05 (1.05)	-0.19 (0.43)
Average	2.39	3.34	7.65	1.41	2.13	6.7	0.64	0.82	7.63	0.00	1.65
Share significant	20%	60%	20%	20%	40%	60%	40%	37.5%	20%	0%	20%

*Note: Symbols \*and \*\* and denote significance at the 1% and 5% level, standard deviation are in parenthesis. Average means the average absolute values of significant coefficients only. Share significant means share of significant cases*

*Source: Authors' calculations*

Table 4 summarizes results about the short-run elasticity of expenditure with respect to output. The results and conclusions for the short-run elasticity of government expenditure to output are not so unequivocal. For all expenditure categories, the average coefficient is 3.14. Although the short-run elasticity of expenditure functions is positive in 62% of the countries in the sample, it's needed to points out on 32% statistical significant of results only. However, the coefficient value above one is consistent with the voracity hypothesis, as it suggests that in response to a given shock to real GDP, government expenditure rises by even more in percentage points.

## Conclusion

The aim of this article was to provide direct empirical evidence on cyclicity and the long-term and short-term relationship between government expenditure and output in five selected European countries (namely Bulgaria, Czech Republic, Hungary, Romania and Slovakia) in a period 1995–2009. We analyzed annual data on government expenditure in compliance with the COFOG international standard. Although the theory implies that government expenditure is countercyclical, our research does not prove that. The results confirm procyclical development of

government expenditure on GDP, Wagner's law and voracity effect in selected EU countries during 1995–2009.

We used Johansen cointegration test and the error correction model. Output and government expenditure are cointegrated for at least four of the expenditure functions in every country and it implies a long-term relationship between government expenditure and output. The government expenditure functions are procyclical in most countries (91% cases in the sample). Average value of long-run elasticity coefficient is 1.72 for all expenditure functions, 1.16 for total government expenditure. It is consistent with the interpretation of Wagner's law and indicates that the public sector is increasing in relative importance in the long-term. The coefficient for long-run elasticity was significant for total expenditure, Economic affairs (G40), Health (G70), Recreation, culture and religion (G80) and Social protection (G100) in all cases (countries). This is important as these expenditure functions include more than 60% of total government expenditure.

We also analyzed the short-run relationship between expenditure and output. Results are not unambiguous due to relatively low statistical significance (32%). However, the coefficient values (average is 3.14) confirm the voracity hypothesis, as they suggest that in response to a given shock to real GDP, government expenditure will rise by even more in percentage points.

### **Acknowledgement**

This article ensued thanks to the support of the grant GAČR 403/11/2073 "Procyclicality of financial markets, asset price bubbles and macroprudential regulation".

### **References**

- [1] ABBOTT, A., JONES, P. Procyclical government spending: Patterns of pressure and prudence in the OECD. In *Economics Letters*, 2011, Vol. 111, pp. 230–232. ISSN: 0165-1765.
- [2] AKITOBY, B. *et al.* Public spending, voracity, and Wagner's law in developing countries. In *European Journal of Political Economy*, 2006, Vol. 22, Iss. 4, pp. 908–924. ISSN: 0176-2680.
- [3] ALESINA, A. *et al.* Why is fiscal policy often procyclical? In *Journal of the European Economic Association*, 2008, Vol. 6, Iss. 5, pp. 1006–1030. ISSN: 1542-4774.
- [4] ERICSSON, N., MCKINNON, J. Finite sample properties of error correction tests for cointegration. In *Econometrics Journal*, 2002, Vol. 5, pp. 285–318. ISSN: 1368-4221.
- [5] FIORITO, R., KOLLINTZAS, T. Stylized facts of business cycles in the G7 from a real business cycles perspective. In *European Economic Review*, 1994, Vol. 38, pp. 235–269. ISSN: 0014-2921.
- [6] GALÍ, J. Government size and macroeconomic stability. In *European Economic Review*, 1994, Vol. 38, pp. 17–132. ISSN: 0014-2921.

- [7] GANELLI, G. The international effects of government spending composition. In *Economic Modelling*, 2010, Vol. 27, Iss. 3, pp. 631-40. ISSN 0264-9993.
- [8] GAVIN, M. et al. *Managing fiscal policy in Latin America and the Caribbean: Volatility, procyclicality, and limited creditworthiness*. IDB Working Paper No. 326/ 1996. [cit. 2011-02-25]. Available from WWW: <http://econpapers.repec.org/paper/idbwpaper/4032.htm>
- [9] GAVIN, M., PEROTTI, R. Fiscal policy in Latin America. In *Macroeconomics Annual*, 1997, Vol. 12, pp. 11–70. ISSN: 1537-2642.
- [10] HAMERNÍKOVÁ, B. et al. *Komparace vývoje veřejných výdajů ve vybraných zemích EU* [online]. 2009 [cit 2010-11-10]. Url: [http://kvf.vse.cz/wp-content/uploads/2010/06/1239726368\\_sb\\_hamernikovamaaytovaullikova.pdf](http://kvf.vse.cz/wp-content/uploads/2010/06/1239726368_sb_hamernikovamaaytovaullikova.pdf).
- [11] HERCOWITZ, Z., STRAWCZYNSKI, M. Cyclical ratcheting in government spending: Evidence from the OECD. In *Review of Economics and Statistics*, 2004, Vol. 86, Iss. 1, pp. 353-61. ISSN: 1530-9142.
- [12] JOHANSEN, S. Cointegration and Hypothesis Testing of Cointegration Vectors in Gaussian Vector Autoregressive Models. In *Econometrica*, 1991, Vol. 59, Iss. 6, pp. 1551–1580. ISSN: 1468-0262.
- [13] KAMINSKY et al. When it Rains, it Pours: Procyclical Capital Flows and Macroeconomic Policies. In *Nber Macroeconomics Annual*, 2004, pp. 11–53. ISBN: 978-0-262-57229-3.
- [14] LANE, P. R. International perspectives on the Irish economy. In *Economic and Social Review*, 1998, Vol. 29, Iss. 2, pp. 217-22. ISSN: 0012-9984.
- [15] LANE, P. R. The cyclical behaviour of fiscal policy: Evidence from the OECD. In *Journal of Public Economics*, 2003, Vol. 87, Iss. 12, pp. 2661-75. ISSN: 0047-2727.
- [16] MUTASCU, M., MILOS, M. Optimal Size of Government Spending. The Case of European Union Member States. In *Annales Universitatis Apulensis Series Oeconomica*, 2009, Vol. 11, Iss. 1, pp. 447- 456. ISSN: 1454-9409.
- [17] PEACOCK, A., SCOTT, A. The curious attraction of Wagner's law. In *Public Choice*, 2000, Vol. 102, pp. 1–17. ISSN: 0048-5829.
- [18] RAJKUMAR, A. S., SWAROOP, V. Public spending and outcomes: Does governance matter? In *Journal of Development Economics*, 2008, Vol. 86, Iss. 1, pp. 96-111. ISSN: 0304-3878.
- [19] SZAROWSKÁ, I. Public Spending Cyclicity and Wagner's Law in Central and Eastern European Countries. In *Acta Universitatis Agriculturae et Silviculturae Mendeleianae Brunensis*, 2012, Vol. LX, Iss. 2, pp. 383-390. ISSN: 1211-8516.
- [20] TALVI, E., VEGH, C. A. Tax base variability and procyclical fiscal policy in developing countries. In *Journal of Development Economics*, 2005, Vol. 78, pp. 156–190. ISSN: 0304-3878.
- [21] WAGNER, A. Staat in nationalökonomischer Hinsicht. *Handwörterbuch der Staatswissenschaften*. 3rd ed. Jena: Fischer, 1911, pp. 743–745.

## **Contact Address**

**Ing. Irena Szarowská, Ph.D.**

Silesian University in Opava, School of Business Administration, Department of Finance

Univerzitni nam. 1934/3, 733 40 Karvina, Czech Republic

E-mail: [szarowska@opf.slu.cz](mailto:szarowska@opf.slu.cz)

Phone number: +420 596 398 215

Received: 29. 04. 2012

Reviewed: 15. 09. 2012

Approved for publication: 01. 11. 2012

# INFORMATION AND COMMUNICATION TECHNOLOGIES AND THEIR BENEFITS FOR MEDIUM AND LARGE-SIZED ENTERPRISES

Ondřej Tichý

**Abstract:** *The primary research, which is brought by this paper, focuses on medium and large-sized enterprises in sectors of information and communication technologies (ICT). It investigates their attitude to the ICT that they use. Based on these ICT, the article is looking for trends set by the companies. Then, these trends could be considered as an inspiration for companies from other sectors of business.*

*The research results have shown that the specially developed software belongs between the most often implemented ICT tools in the last seven years by the questionnaire companies. The research also showed that this ICT tool of all, which they have implemented, is the most beneficial at a tactical level.*

*Another part of analysis, where the companies should chose benefits that arose from the implementation, pointed out that they are focused on two basic clusters of benefits. The first contains: improved teamwork and increased efficiency and effectiveness. The other cluster contains: reduced costs, improved service quality and improved integration of business functions. The research also showed that the surveyed companies consider the ICT only as a tool, which simplifies work.*

**Keywords** *Information and Communication Technologies, Organizational Structure, Company, Benefits.*

**JEL Classification:** *L860, L290, M150.*

## Introduction

The main purpose of this work is to determine a role of information and communication technologies (ICT) in the Czech companies. These technologies have experienced pervasive development in recent years and the research, here, brings reasons, which led to their deployment in the selected companies and also tries to identify their benefits.

The companies that were selected for this research act in an ICT sector of business. These companies work with the ICT at a daily range. Therefore, they have an overview about the news in the sector and definitively some of them tested in their environment. Hence, this article may serve as an inspiration for companies from other sectors to determine the trend of deploying the new ICT in organizational structures of the companies.

The text is divided into two parts. The first is carried out by a secondary research of relevant literature. The second part presents the results of a primary research with theirs discussion.



## 1 Statement of a problem

An organizational structure is a certain organizational system, where the work is divided, grouped and coordinated in a company. Managers use the organizational structure as a tool for achieving targets. When they define or change it, it is called a design of company. This process includes six key elements: specialization of labour, division of departments, chain of command, dimension of control, centralization and decentralization, formalization.

The reasons, why it is important to have organized work, are based on historically verified facts. Whenever activities of a group of people were organized, those groups always achieved better results than the group that is not organized [18]. Over the years, the organizational structures were the subject of lots of researches, to find such a structure that would best help employees to perform their work.

Authors Dědina, Odcházal state that the main responsibilities of the organizational structure include: (1) to ensure the effectiveness of information flow within the organization, (2) to achieve effective coordination and integration of varied activities in the organization [4]. This effective performance of an organization defined for instance Vysušil: (1) a hierarchical link enables to achieve set objectives to a company, (2) a hierarchical link leads to fast and flexible decision making, (3) it allows management of production control by qualified employees, (4) on the basis of these relations could quickly identify managers who do not perform work in accordance with the objectives [20].

It may seem from the previous paragraphs that there is some kind of the organizational structure, which can be always successfully used, but it is not true. The organizational structure always depends on a selected business strategy [17]. In practice, the companies' organizational structures can be broken down according to various criteria, relationships or links. Therefore, we distinguish the structures, which are divided according to the degree of formalization, the degree of centralization or the degree of complexity [3]. It is also possible to divide them according to a specialization, according to an association of activities [15], according to a division of powers [2] and so on.

There is increasingly used so-called model of a virtual organizational structure in the last years. It is characterized by a flexible structure varies according to the requirements of business processes, activities and tasks [10], [15]. These modern organizational structures are directly dependent on information and communication technologies (ICT). It could not fulfil its basic function without their contribution.

The ICT caused major changes in companies in terms of social and economic issues [9]. Like many other inventions in the past, these technologies were developed in a military environment and gradually were spread to almost all economic activities [19]. Today, the ICT are a fundamental pillar of the knowledge economy [16]. Their main domain is that they apply knowledge and, at the same time, generate additional knowledge (some authors speak directly about the "third industrial revolution") [9]. Therefore, the ICT is considered as a vital source of a competitive advantage for companies. The ICT also enable companies to reduce costs and / or increase the

effectiveness of processes [1], [5], [8]. We can say that it completely changed the way, how the existing businesses operate [13].

The ICT include for example networks, computers, PDA's (generally hardware), software and other systems for data / information processing and transmitting, for example a telephone [6], [7]. Plumb, Zamhir further argue that the ICT companies can improve a communication, the ability to exchange data, to enhance teamwork, to improve customer relationships, competitive advantage and so on [12]. According to them, it stems from the fact that the ICT enable obtain, process, accumulate and exchange information [12].

They further divide the ICT within organizations into three levels, depending on what benefits provide on a given level: (1) operational level, (2) tactical level, (3) strategic level [12]. The authors also specify each of these levels:

#### **Operational level**

- Improved data management
- Improved communication
- Improved decision-making
- Reduced paperwork
- Reduced labour costs
- Reduced rework
- Improved ability to exchange data
- Improved response time to queries
- Improved control of cash-flow

#### **Tactical level**

- Improved response to changes
- Improved service quality
- Improved teamwork
- Promotes pro-active culture
- Improved planning times
- Reduced time to compile tenders
- Improved integration with other business functions
- Reduced time to prepare cost plans
- Improved effectiveness and efficiency

#### **Strategic level**

- Improved growth and success
- Reduced marketing costs
- New technology leadership
- Improved market share
- Market leadership
- Improved customer relations
- Improved customer/supplier satisfaction
- Improved competitive advantage
- Improved organizational and process flexibility

## **2 Methods**

The prior chapter contains the secondary research in a field of the ICT and their deployment in the organizational structures of companies. The next chapter

brings results from the primary research. It was drafted on the basis of combination of a qualitative and a quantitative research among companies, which operate in the Czech Republic. The medium and large-sized enterprises were chosen (the number of employees was chosen as a criterion of division, as it is often stated in the literature) in a sector of ICT.

It is expected that these companies follow the latest trends in the ICT (often developed by themselves). There were not selected small-sized enterprises, because their organizational structures are simple enough to not fully exercise benefits from the ICT, which are important for this research.

A list of companies was obtained from the Amadeus database<sup>6</sup>, where it is possible to sort them according to selected criteria. The selection criteria are reported in the Tab. 1.

**Tab. 2: Selection criteria for the research**

Criterion	Number of companies	
	1 criterion	Cumulative
State: Czech Republic	450 870	450 870
Status: Active	16 116	436 760
Sector: ICT	507 886	5 054
Number of employees: 51+	417 130	133

*Source: Author*

The database shows that there are a total of 450.870 companies in the Czech Republic (on November 15, 2011). There were chosen only active companies, from the ICT sector and those, in which the number of employees is at least 51. As a result 133 companies fits to the selected criteria. During the processing there were excluded 30 companies, which could not be traced or were not appropriate for the research<sup>7</sup>. The qualitative research was conducted with ten selected companies from the list. Subsequently, on its results the question for a questionnaire was compiled. The questionnaire was sent to the rest of 93 companies from the list with a request to fill. That formed the quantitative research<sup>8</sup>. The questionnaire involves these questions:

- Q1: Which the most important ICT tool was implemented in your company since 2005?
- Q2: Which of these ICT does your company consider the most beneficial and why?
- Q3: Contrary, which of these ICT did not bring expected benefits and why?

<sup>6</sup> Amadeus is a database with a list of worldwide companies, more information can be found on: <http://bvdinfo.com/home.aspx>.

<sup>7</sup> The list contained also organizational units of the state and so on.

<sup>8</sup> A combination of a qualitative and a quantitative form of research is called „data triangulation“ [11].

- Q4: Which benefits brought the ICT implementation that you have mark as the most beneficial? (Followed by a list of benefits inspired by the three levels of benefits, see above.)
- Q5: Has the organizational structure of your company been changed due to the implementation of the selected ICT, eventually how? (Followed by a choice of several options, see the next chapter.)

### 3 Research results

SPSS was used to process the results. There were returned a total of 39 responses, it represents almost 38% of the relevant companies from the basic set. The results in individual questions are stated in the following paragraphs.

In the first question, the representatives of companies could choose from the offered ICT, which were relevant in this case. It is important to note that they could choose more than one choice, because they definitively implemented more than one in that time. The Fig. 1 brings overall results.

**Fig. 1: The most important ICT in companies**

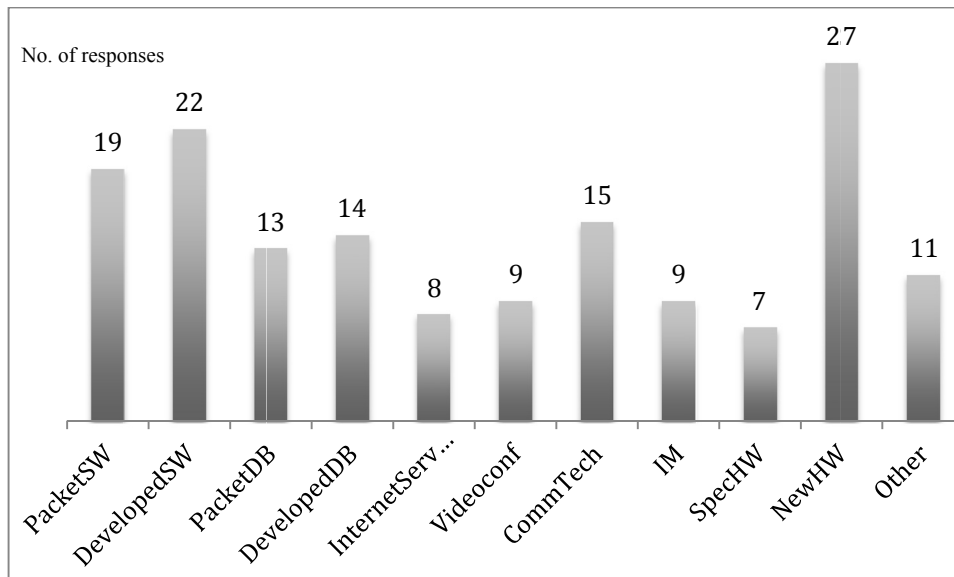

*Source: author*

The “new hardware” was the most frequent response. However, this option is definitively related to the obsolescence of existing computers and their natural renewal. The figure also shows that the “specially developed software” was the second most frequent option. Taking into account described the natural renewal hardware; it is possible to consider this option as the most important ICT tool for the selected companies.

The first question’s result is reflected in a response to the second question, where the respondents should choose the most beneficial ICT. The Tab. 2 brings results and the “specially developed software” option also prevails.

**Tab. 3: The most beneficial ICT for companies**

Type	Frequency	Per cents	Cumulative per cents
Packed SW	5	13,2	13,2
Developed SW	9	23,7	36,8
Packed Database	5	13,2	50,0
Developed Database	6	15,8	65,8
Videoconference	1	2,6	68,4
Communication Tech.	3	7,9	76,3
IM Communication	5	13,2	89,5
New Hardware	4	10,5	100,0

*Source: Author*

In the third question, the respondents had to state, which ICT did not succeed. The results showed that almost 80% of respondents could not give the right answer, because everything works fine. They often argued that everything must be properly tested before the implementation. There has to be pointed out that the survey took place among the ICT companies, where mostly ICT experts are employed. So, it would be rather surprising, if the result were different. The Tab. 3 brings the overall results of the unsuccessful ICT.

**Tab. 4: Unsuccessful ICT for companies**

Type	Frequency	Per cents	Cumulative per cents
None	30	78,9	78,9
Packed SW	1	2,6	81,6
Developed SW	4	10,5	92,1
Packed Database	1	2,6	94,7
Developed Database	1	2,6	97,4
Videoconference	1	2,6	100,0

*Source: Author*

The fourth question takes into account strategic, tactical and operational benefits as it was described above. The respondents could choose from more than one offered claim (often without having the awareness of this possible division). The results are shown in the Tab. 4.

**Tab. 5: ICT benefits for companies**

<b>Benefits</b>	<b>Option</b>	<b>Responses</b>	<b>Per cents</b>
<b>Operational</b>	Reduced paperwork	8	21
	Management support (decision-making, data mining...)	17	45
	Improved control of cash-flow	7	18
	Improved communication	5	13
	Improved response time to queries	13	34
	Improved ability to exchange data	19	50
<b>Tactical</b>	Improved planning times	5	13
	Improved effectiveness and efficiency	29	76
	Improved integration with other business functions	8	21
	Improved teamwork	3	8
	Improved service quality	21	55
<b>Strategic</b>	Improved customer/supplier satisfaction	8	21
	New technology leadership	14	37
	Reduced marketing costs	0	0
	Improved growth and success	3	8
	Improved competitive advantage	13	34
<b>Other</b>	Offer new products	2	5
	New project	7	18
	Other	2	5

*Source: Author*

In order to determine, which benefits give the greatest weight to the companies there was established a formula. The formula is trying to capture the weight differences between categories, taking into account the differences in each category. This way, they could be compared. The formula is presenting in following:

$$\frac{\sum_{i=1}^N n_k}{39 \times N} [-] (1),$$

where N is the number of individual benefits in a given category (here, the table's rows in the category).  $n_k$  is the variable, which expresses the real answers for each contribution (within the same row in the table). And a total of 39 responses were obtained. The Tab. 5 presented results.

**Tab. 6: Weight benefits for companies**

	Benefits		
	Operational	Tactical	Strategic
Results	0,29	0,34	0,19

*Source: Author*

The table shows that the companies focus especially on medium-term goals represented by the tactical benefits (those have the highest weight). The operational benefits (short-term goals) follow and the strategic benefits (long-term goals) have the lowest importance.

Another question examined whether the ICT lead to change in the organizational structure of the selected companies within two years after their implementation. Here, the respondents could select from several options. The Fig. 2 brings these options and the results.

**Fig. 2: ICT and change in an organizational structure**

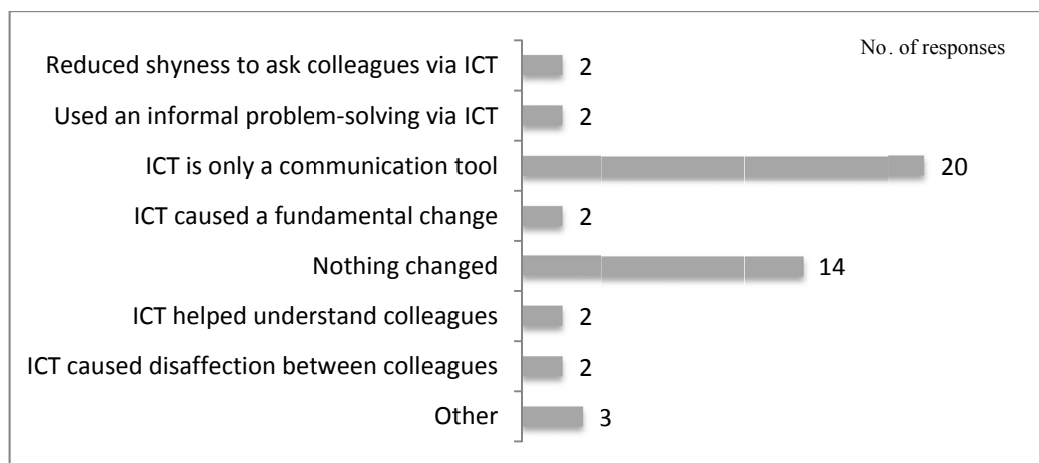

*Source: Author*

The results show that the selected companies use the ICT especially as a communication tool, which simplifies work or any change was registered. Other options are not significant.

### **3.1 Benefit analysis**

The benefits, which were used in the fourth question, were also the object of a multidimensional scaling. The analysis is focused on a cluster of benefits, which the companies follow with the ICT implementation.

The multidimensional scaling allows showing the relationship between categories using multiple variables. An aim of the analysis is to reduce the multidimensional space of variable vectors into a smaller space dimensions, usually a two-dimensional space. Then, the output of analysis enables to identify groups of similar categories. During the interpretation, it is being stated: the more individual points in a space are closer, the greater similarity is between the corresponding categories. The location of individual points are often being interpreted toward to the main axes [14]

### 3.1.1 Operational level

The Fig. 3 shows that all benefits are quite different at the operational level. As a conclusion can be said, that the operational level does not have the prevailing trend. Every company deals with their own specific operational requirements without any sector's obvious trend.

**Fig. 3: Multidimensional scaling at an operational level**

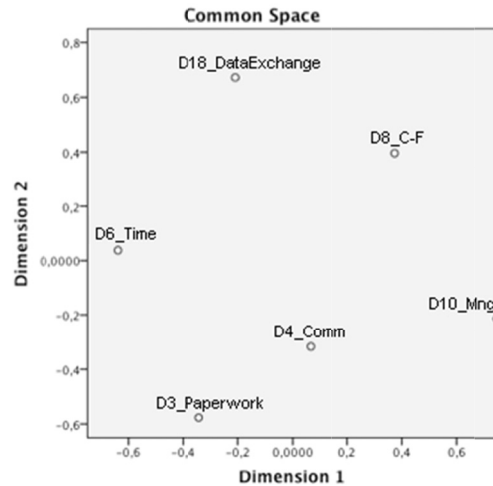

Source: Author, SPSS Output

### 3.1.2 Tactical level

The Fig. 4 represents the tactical level of benefits. There may be a horizontal axis used as a dividing parameter. It can be said that the companies focus on two basic trends, which are represented by two clusters of benefits. The first consists of: improved integration with other business functions, improved planning times and improved service quality. The other contains: improved effectiveness and efficiency and improved teamwork.

**Fig. 4: Multidimensional scaling at a tactical level**

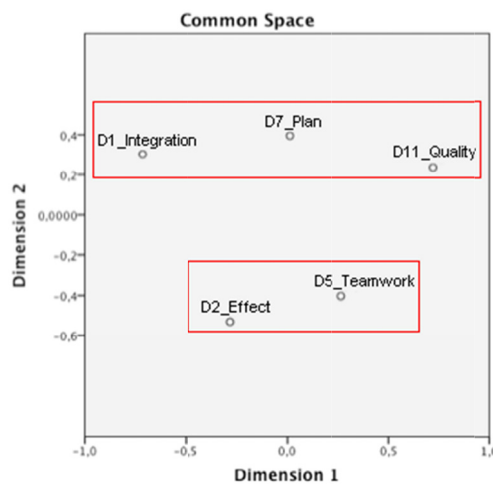

Source: Author, SPSS Output



### 3.1.3 Strategic level

At the strategic level, represented by the Fig. 5, the horizontal axis could also be used as the dividing parameter. Then, there are also apparent two basic trends, which are represented by two clusters of benefits. The first cluster contains: improved growth and new technology leadership. The second one consists of: improved customers / suppliers satisfaction and reduced marketing costs. The option “improved competitive advantage” does not fit any cluster therefore it was excluded.

**Fig. 5: Multidimensional scaling at a strategic level**

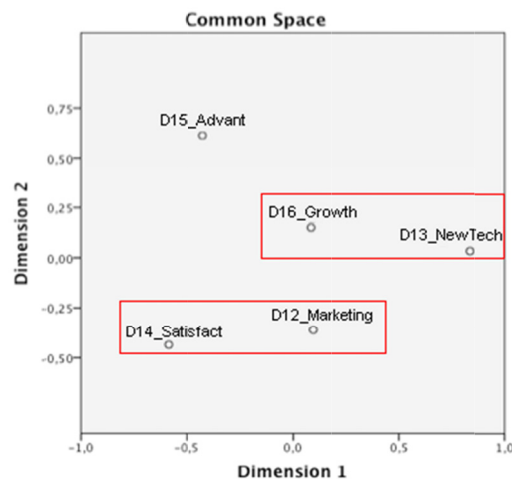

Source: Author, SPSS Output

## 4 Discussion

In today, the vast majority of companies are focused the short-term goals (especially earnings) and that is why the author of this article expects that the operational benefits will gain more importance in future and at the operational level there will be apparent the cluster of: reduced paperwork, management support and improved communication. In other relationship authors Plumb, Zamhir also pointing out day-to-day managerial practices as the most important option [12].

The author fully agrees with the result, which shows that the companies consider the ICT only as a communication tool. Everybody, who expects for example the fundamental change, has to take into account that the ICT are developed mostly to simplify people's work.

## 5 Limitations and further research

The limitations of the research lie in the limited number of responses; therefore the results cannot be generalized.

There is no possibility of running further research in this field, whereas there had been used the whole basic set of the companies from the Czech Republic. On the other hand, further research would try to examine the differences in these trends between the Czech Republic and other countries. Definitely, interesting research would verify set trends by this article in other sectors of business after a couple of months. Another

possible research could be carried out after several years. This way, the trends' development in the ICT implementation in companies could be captured.

## Conclusion

This research showed that medium and large-sized enterprises in the ICT sector focused mainly on the specially developed software. They consider it as one of the most important ICT tool that they have implemented in the last seven years. In this regard, almost 80% of the respondents state that there is not any significant technology, which did not proved in their practise.

This article also tried to identify benefits that have been followed in the implementation of the most important ICT. Subsequent analysis determined that the selected companies focused mainly on the benefits at the tactical level. Especially, there are two basic clusters of trends. The first said that companies want to improve teamwork and increase their effectiveness and efficiency. The second cluster of the benefits said that companies want to improve integration with other business functions, improve planning times and improve service quality.

The results also show that companies consider the ICT only as a tool that simplifies work. This result, however, is in opposition to the EU's effort. In fact, the EU considers the ICT as an engine of economic growth in the near future and therefore supports it from its funds.

## Acknowledgement

This contribution was supported by: FP-S-11-3/1417, "Inovativní přístupy v managementu a v marketingu v globálním evropském prostředí".

## References

- [1] BRYNJOLFSSON, E., HITT, L. Productivity, profitability and consumer surplus: Three different measures of information technology value. *In MIS Quarterly*, 1996, Vol. 20, Iss. 2, pp. 121–142.
- [2] CEJTHAMR, V., DĚDINA, J. *Management a organizační chování*. Praha: Grada publishing, 2010, 352 p. ISBN 978-80-247-3348-7.
- [3] CHARVÁT, J. *Firemní strategie pro praxi: praktický návod pro manažery a podnikatele : od firemní kultury po schopnost vydělávat peníze : příklady a studie z praxe v ČR*. Praha: Grada Publishing, 2006, 201 p. ISBN 80-247-1389-6.
- [4] DĚDINA, J., ODCHÁZEL, J. *Management a moderní organizování firmy*. Jihlava: Grada Publishing, 2007, 328 p. ISBN 978-80-247-2149-1.
- [5] DON SANTOS, B., SUSSMAN, L. Improving the return on IT investment: The productivity paradox. *In International Journal of Information Management*, 2000, Vol. 20, Iss. 6, pp. 429–431.
- [6] E-BUSINESS W@TCH. *The European e-Business Report*. [cit. 2012-04-04]. Available at WWW: <[http://ec.europa.eu/enterprise/archives/e-business-watch/key\\_reports/documents/EBR06.pdf](http://ec.europa.eu/enterprise/archives/e-business-watch/key_reports/documents/EBR06.pdf)>.

- [7] KLOUDOVÁ, J., et al. *Kreativní ekonomika : vybrané ekonomické, právní, masmédiální a informatizační aspekty*. Bratislava : Eurokódex, 2010. 216 p. ISBN 978-80-894-4720-6.
- [8] KUDYBA, S., DIWAN, R. The impact of information technology on U.S. industry. *In Japan and the World Economy*, 2002, Vol. 14, Iss. 3, pp. 321–333.
- [9] OLLO-LÓPEZ, A., ARAMENDÍA-MUNETÁ, E. ICT impact on competitiveness, innovation and environment. *In Telematics and Informatics*, 2012, Vol. 29, Iss. 2.
- [10] PALÁN, J. *Virtuální systémově – heterogenní model organizace*. [cit. 2012-04-03]. Available at WWW: <[http://www.agris.cz/Content/files/main\\_files/61/139554/palan.pdf](http://www.agris.cz/Content/files/main_files/61/139554/palan.pdf)>.
- [11] PAVLICA, K., et al. *Sociální výzkum, podnik a management : průvodce manažera v oblasti výzkumu hospodářských organizací*. Praha: Ekopress, 2001, 161 p. ISBN 80-86119-25-4.
- [12] PLUMB, I., ZAMFIR. A. Use Of Ict In Sme's Management Within The Sector Of Services. *In The Journal of the Faculty of Economics – Economic*, 2008, Vol. 4, Iss. 1, pp. 481-487.
- [13] RUIZ-MERCADER J., MERONO-CERDAN A. L., SABATER-SANCHEZ R. Information technology and learning: Their relationship and impact on organisational performance in small businesses. *In International Journal of Information Management*, 2006, Vol. 26, Iss. 1, pp. 16-29.
- [14] ŘEZANKOVÁ, H. *Analýza dat z dotazníkových šetření*. 2nd Edition. Praha: Professional Publishing, 2009, 217 p. ISBN 978-80-7431-019-5.
- [15] SEMORÁDOVÁ, P. *Předpoklady vývoje organizačních struktur*. Brno : VUT Brno, 2009, 130 p.
- [16] TAKAHASHI, K. I., et al. Environmental impact of information and communication technologies including rebound effects. *In International Symposium on Electronics and the Environment (ISEE'04)*, 2004, pp. 13–16.
- [17] VÁGNER, I. *Systém managementu*. 2nd Edition. Brno: Masarykova univerzita, 2007, 432 p. ISBN 978-802-1042-643.
- [18] VEBER, J., et al. *Management*. 2nd Edition. Praha: Management press, 2009, 449 p. ISBN 978-80-7261-200-0.
- [19] VILASECA, J., et al. El impacto de las TIC en la empresa turística: el caso de Cataluña. *In UOC, Working Paper Series*, 2006.
- [20] VYSUŠIL, J. *Plánování není přežitek*. Praha: Profess, 1993, 93 p. ISBN 80-852-3518-8.

### Contact Address

**Ing. et Ing. Ondřej Tichý**

Brno University of Technology, Faculty of Business and Management, Department of Management

Kolejní 2906/4, 612 00, Brno, Česká republika  
Email: [tichy@fbm.vutbr.cz](mailto:tichy@fbm.vutbr.cz)  
Tel. číslo: +420 54114 3378

Received: 26. 04. 2012

Reviewed: 06. 08. 2012

Approved for publication: 01. 11. 2012

# IMPROVING THE QUALITY OF PROCESSES BY USING KNOWLEDGE CONTINUITY ENSURING

Hana Urbancová, Josef Kříž

**Abstract:** *In the current knowledge economy the workers are the key competitive advantage and their knowledge is the most important asset in the various business processes. If people leave the organization they will take their knowledge with them and it can jeopardize the quality of the processes. This paper focuses on the topic of the ensuring the knowledge continuity as a tool for fluent improvement of processes in organizations. The processes and the areas were identified within the organization by means of induction. The processes are improved by using the knowledge continuity management. The benefits of the processes were measured by quantitative research, by using the questionnaire survey in organizations in the Czech Republic. One of the conclusions of the paper is that with correct knowledge continuity the quality of the processes in the organization can be increased together with the performance.*

**Keywords:** *Knowledge, Knowledge continuity, Quality, Process, Benefits, Quantitative survey.*

**JEL Classification:** *J24.*

## Introduction

The aim of organizations is achieving the organization's performance with the application of efficient management. The means for achieving organizations' aims is the right and efficient functioning of individual processes in which the organization's employees who are the carriers of knowledge take part [19]; [9]. The right management of processes requires to cope with managerial functions, such as correct and timely decision-making and the selection of suitable procedures. The process of decision-making is based not only on analyses and experience, but also on knowledge [3]; [5]; [6].

## 1 Statement of a problem

The objective of the article is to identify the benefits from process arising from the application of knowledge continuity management in organizations. The identification is based on analysis of results of the quantitative survey. A sub-objectives is to make a comparative analysis of the benefits achieved from using the knowledge continuity in organizations according to size (i.e. by number of employees) and to test whether there are statistically significant differences in the various categories of processes and size of organization and to identify the importance to ensure the knowledge continuity for quality processes and decision making.

### 1.1 Theoretical background of the work

Processes in organizations consist of an order or sequence of activities arranged logically whose output represents a benefit for the customer [16]. [17] adds that it is

a set of one or more interconnected activities that collectively contribute to the achievement of the goal, usually in relation to the organizational structure that defines functional roles and relationships. Processes exist in each and every organization and significantly influence its performance [16]. The improvement of processes is based on targeted management of processes by the organization's management. In other words, based on the understanding of critical problems, their causes, connections and the determination of their so-called "constraints" (Theory of Constraints – TOC). It is a new management approach based on the location of constraints in processes whose improvement (elimination) leads to the enhancement and ongoing improvement of processes in an organization [8]. Knowledge continuity may also be defined as the so-called process "constraint". The key idea of TOC is that if a system is free of constraints, the flow would, without any time limitation, continue to grow. In other words, it is possible to say that in the case of ensuring knowledge continuity between a leaving employee and his/her successor it will mean the elimination of a constraint limiting the efficiency of individual processes.

The protection of organizational sources is a part of an organization's business continuity [19]. Organizational sources also include people as a production factor without which organizations cannot operate. They are the carriers of knowledge [14], and therefore the protection of knowledge (as a production source) and of employees as knowledge carriers should be one of organizations' priorities [12]. Ensuring business and process continuity enhances organizations' productivity [13] by maintaining current competitive advantages or gaining of a new competitive advantage through the implementation and utilization of new opportunities. Knowledge continuity is part of organizations' operation continuity [4]; [7]; [19].

Knowledge continuity is an area associated with knowledge management and defines the ratio of knowledge retained by the organization when a knowledge employee leaves the organization and the knowledge leaving together with the knowledge employee. Knowledge continuity management is a branch of knowledge management (see Fig. 1). While knowledge management focuses on the capturing and sharing of know-how important for colleagues who have similar tasks in the organization, knowledge continuity management is targeted at the transfer of critical knowledge (minimum knowledge base, knowledge decrease below this level leads to the knowledge discontinuity) from departing employees to their successors [1]; [2].

If the leaving of an employee does not lead to changes in the original knowledge base, the successor will take over all critical knowledge of the leaving employee. In other words, the aim of knowledge continuity is to maintain the original knowledge base of the leaving employee.

**Fig. 1: Management of knowledge base continuity**

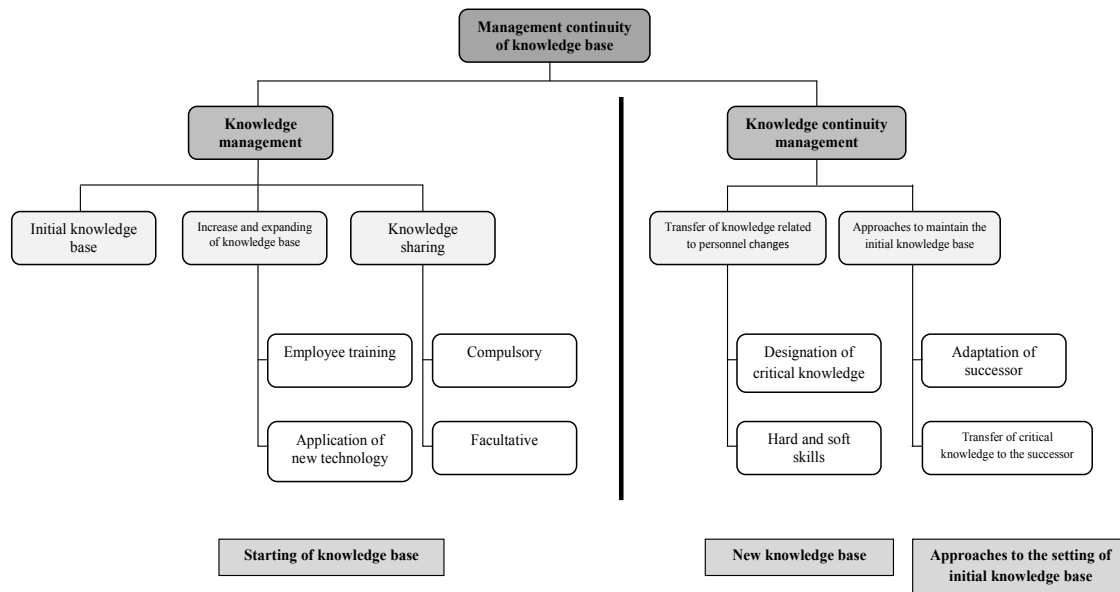

*Source: Author*

Without a suitable process for retaining this knowledge and its transfer to the successor, this knowledge is lost for the organization and thus the performance of the organization is endangered. Performance means an ability to achieve personal, procedural, team and organizational goals. As a result, newcomers who replace leaving employees spend more time to start working as important findings and information of their predecessors is lost. The problem of unsecured transfer leads to time and material losses in the quality of process management. This paralyzes organizations' abilities to act flexibly and keep track [18].

The above implies that managers have to pay attention to ensure knowledge continuity and make this activity part of managerial roles in order to achieve an optimal level of business continuity as without knowledge employees holding knowledge critical for the organization it is impossible to ensure business continuity.

## 2 Methods

The first part of the article is focused on the theoretical approaches to knowledge continuity management and increasing the efficiency of business processes. The second part analyses the outcomes of the survey carried out among managers of organizations in the Czech Republic. The article has been processed based on the analysis of secondary sources, outcome synthesis and the evaluation of results of a questionnaire survey.

The questionnaire consisted of 7 questions from the area of assessment of the benefits associated with the implementation of knowledge processes, knowledge management and knowledge continuity management. For evaluation surveys and for purposes of comparative analysis tools descriptive statistics (absolute frequency) and non-parametric testing were used. The nonparametric Mann - Whitney U test was used at the significance level of 0.1. Selected non-parametric test tested whether the

differences between the averages of the answers of respondents from each organization according to size are statistically significant.

The data for the evaluation of the processes where the quality is improved by the application of the knowledge continuity management, has been gathered through a quantitative survey, i.e. a questionnaire survey, in which 148 higher and middle management managers from various organizations took part. The questionnaire was distributed to 814 respondents from 580 organizations. The overall questionnaire return was 18.18%, i.e. 148 respondents took part. The selected group of organizations included in the survey has been chosen by means of quota random sampling among organizations situated in the Czech Republic and presented on the Internet and their managers were contacted. The selection criteria for the survey have been set in a way to roughly reflect the proportional representation of organizations according to the sector of economy, organizations' size and middle and top managers' genders in compliance with the figures published by the Czech Statistical Office:

- 15% (85 organizations) from the primary, 15% (85 organizations) from the secondary, and 70% (410 organizations) from the tertiary sector;
- according to the organizations' size (number of employees): 65% (377 organizations) from small, 20% (116 organizations) from middle-sized, and 15% (87 organizations) from large organizations;
- according to the middle and top managers' gender: male 77.5% (654 managers) and female 22.5% (160 managers).

The selected sample chosen from the basic group is a characteristic sample in all respects and proportionally represents the groups of organizations as selected from the basic group. 55.1% holds a senior management position, 68.9% have university education, 45.5% are in the age group 46-62 years, 70.1% are employees of Czech organizations, 51.5% work in tertiary sector and 38.9% work in the primary sector. 76.6% of respondents were male.

The data have been processed by means of the LimeSurvey application, SPSS 17.0 and the MS Excel 2007 software.

### **3 Problem solving**

Based on the above said it is possible to say that organizational processes represent a complex sequence of activities that are directed at an unambiguously defined goal, that involve at least one employee and that follow certain methodological instructions and procedures. At the same time it is possible to state that organizational processes are areas that organizations need to work on actively.

A survey carried out among managers of organizations at the level of middle and higher management identified areas in which knowledge continuity ensuring will manifest. Based on the data obtained the figures graphically represent benefits arising from the implementation of processes in an organization (Fig. 2) and benefits for individual organizational processes (Fig. 3).



**Fig. 2: Benefits arising from the application of knowledge continuity management in organizations**

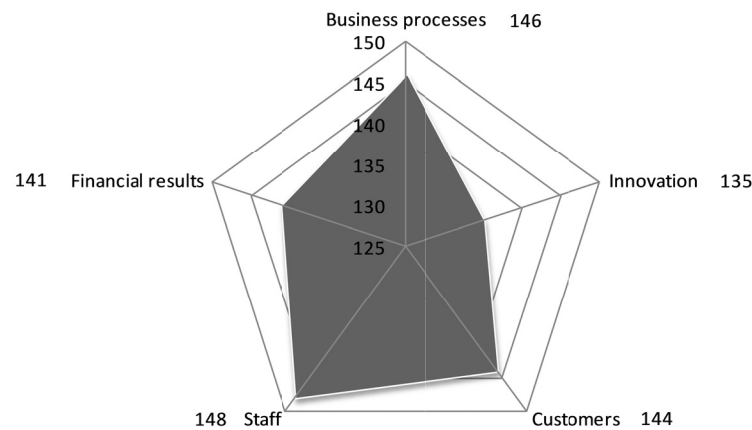

Source: [Author's survey]

In the category of organizational processes, respondents see the major benefits in higher productivity (101 respondents) and the lowering of error rates in processes (92 respondents). A large number of respondents also mentioned the category of further utilization of internal knowledge (69 respondents) and higher process transparency (65 respondents). Respondents who ticked the option “other” did not specify their choice. Only one respondent mentioned that there were no benefits tracked in the category of organizational processes. A more detailed list of benefits is shown in Figure 3.

**Fig. 3: Benefits in classification of business processes**

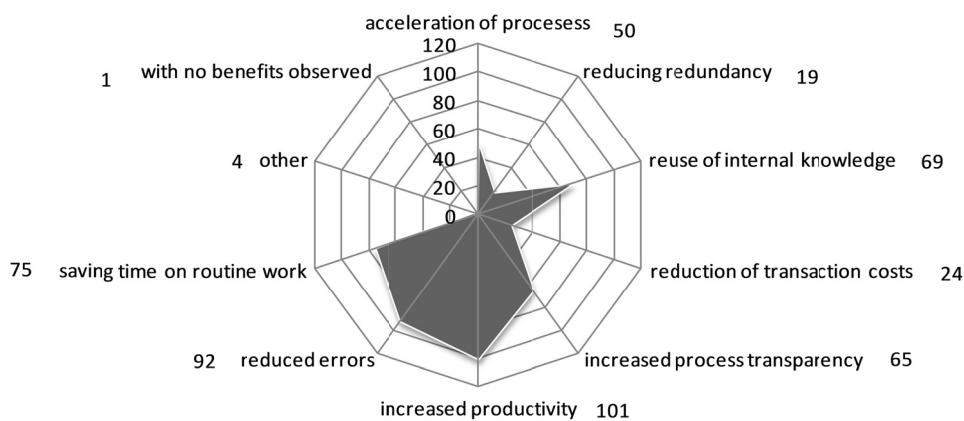

Source: [Author's survey]

In the area of benefits associated with the fundamental business objectives of organizations the research revealed that a total of 105 respondents stated that the biggest benefit lies in the improvement of the organization’s performance, 74 respondents found that it was beneficial in terms of cost lowering, 67 respondents

mentioned the introduction of new methods of work and 57 the increase of profit (Fig. 4).

**Fig. 4: Benefits associated with primary commercial targets of organization**

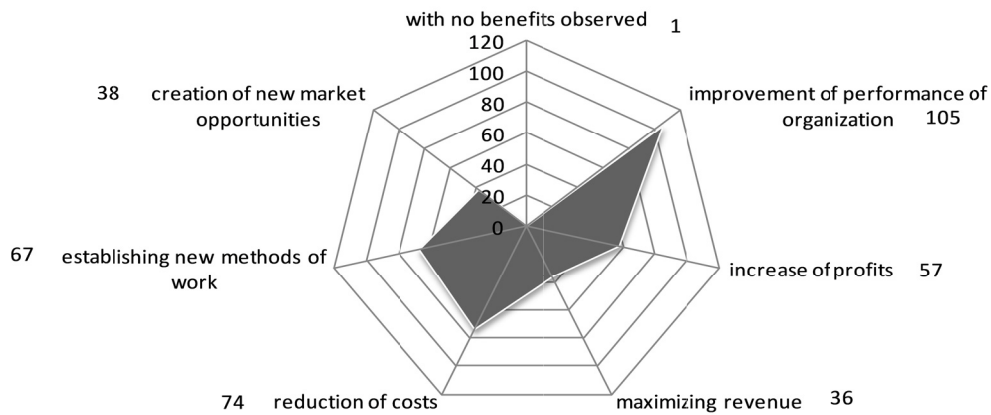

Source: [Author's survey]

Organizations are aware of the fact, that effective knowledge transfer helps in improving of processes and enhancing the competitiveness of the organization. Based on the above, it is also possible to agree with the conclusion of the surveys by [15] that the benefits of knowledge management depend in particular on the manner of acceptance of this conception, its application and adherence by the organization. If an organization applies knowledge continuity management intentionally, if it realises that their employees' knowledge is the greatest asset and efficiently supports knowledge sharing and transfer among current employees, it can expect benefits not only in the area of knowledge utilization and team work, but consequently also in the improved performance of the entire organization, lowering of costs and increasing the productivity including economic and non-economic aspects.

In conclusion the application of the knowledge continuity management contributes to achieving the standard objectives associated with development of organizations. The efficient management, extension, sharing and preservation of employees' knowledge can ensure not only deeper individual, but also the so-called organizational knowledge. In general, the introduction of knowledge processes improves the performance and productivity of the entire organization. The advantages are evident also from the long-term perspective, as there are activities where knowledge, experience and skills transfer takes longer.

### **3.1 The benefits of knowledge continuity ensuring in small and large organizations**

To verify the results and support the conclusions of the article sums calculated responses of the respondents (see Table 1) in the survey took place in each category (business processes, innovation, customers, employees, financial results and the underlying business objectives). Using these sums dependencies between the frequency response in different categories and sizes of organizations were tested using

the Mann - Whitney U non-parametric test (see Table 2) on null hypothesis  $H_0$ : difference between means is statistically significant and the alternative hypothesis  $H_1$ : the difference between means is statistically significant.

**Tab. 1: The sum of responses for each category**

	Size of organizations	Number	Mean	Sum
Business processes	Up to 19 employees	41	38,84	1592,50
	Over 250 employees	46	48,60	2235,50
	Total	87		
Innovation	Up to 19 employees	41	41,61	1706,00
	Over 250 employees	46	46,13	2122,00
	Total	87		
Customers	Up to 19 employees	41	44,13	1809,50
	Over 250 employees	46	43,88	2018,50
	Total	87		
Staff	Up to 19 employees	41	38,77	1589,50
	Over 250 employees	46	48,66	2238,50
	Total	87		
Financial results	Up to 19 employees	41	43,68	1791,00
	Over 250 employees	46	44,28	2037,00
	Total	87		
Basic business objectives	Up to 19 employees	41	40,83	1674,00
	Over 250 employees	46	46,83	2154,00
	Total	87		

Source: [Author's survey]

**Tab. 2: Non-parametric tests depending on the benefits of individual processes and organization size (up to 19 and over 250 employees)**

	Business processes	Innovation	Customers	Staff	Financial results	Basic business objectives
Mann-Whitney U	731,500	845,000	937,500	728,500	930,000	813,000
p - value	,068	,377	,962	,064	,908	,258

Source: [Author's survey]

Comparison in the contribution was made over the category of small organizations up to 19 employees and large organizations of 250 employees (division according to the CSO), where the non-parametric test (for two independent samples) at a significance level  $\alpha = 0.1$  were tested benefits in each category processes. The aim of the comparison was to determine whether the benefits achieved will vary in different categories according to size of organization processes. The results of these two groups of sizes of organizations are presented in the paper due to the fact that in these two categories were identified greatest statistical differences.

The test criterion was established on the basis of calculated p-values (see Table 2), on the basis of which conclusions can be made (evaluation) by a Mann - Whitney U

test. The observed p-value was compared with a specified level of significance. P - value was found to be less than the significance level ( $\alpha = 0.1$ ) in the category of business processes and employees. Therefore in these categories the null hypothesis is rejected.

Based on the Mann - Whitney U test, it can be said that in the category of business processes and categories of employees, there are statistically significant differences in small and large organizations.

Differences in benefits between small and medium sized organizations and between medium and large organizations have been demonstrated, since the p-value was higher than the level of significance.

To substantiate the results there can be mentioned articles and findings of other authors involved in similar researches aimed at benefits of the introduction of knowledge management and knowledge continuity management, for example [10]; [11]; [15].

#### **4 Discussion**

To ensure higher quality of processes, it is essential to ensure knowledge continuity in organizations especially for the following reasons:

- Each employee in an organization is involved in its processes and requires knowledge for his/her activities => in an organization knowledge transfer should be governed by the process of knowledge continuity ensuring.
- By ensuring the maximum level of knowledge continuity it is possible to eliminate the negative consequences of loss of knowledge (for reasons of personnel changes) and maintaining of the quality of processes.
- Knowledge continuity ensuring enhances the quality of decision-making, the quality of the management process and contributes to a better quality of processes (in particular of processes utilizing knowledge) and thus ensures operation of the entire organization.
- It enables the organization to retain knowledge even after the employee who was the holder of the critical knowledge leaves.
- It improves and speeds up the process of initial training of newcomers.

The above reasons are depicted in Figure 5, which shows the progress of individual process steps of ensuring of knowledge continuity leading to the higher performance of organizations.

**Fig. 5: The progress of the individual process steps of knowledge continuity leading to the higher performance of organizations**

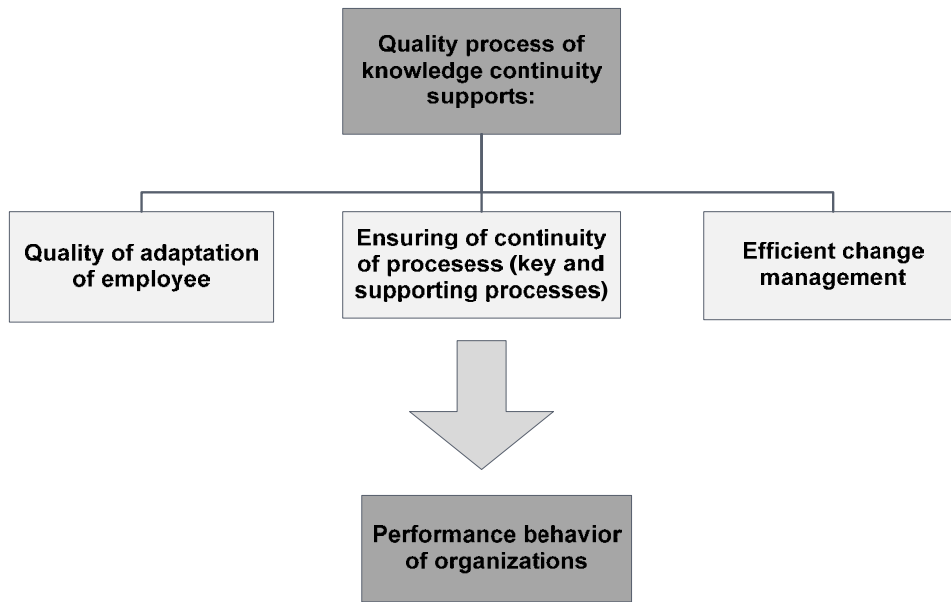

Source: Author

Finally, it is important to realize that targeted sharing of critical knowledge translates into a more rapid process of individual and organizational learning (better and faster training of new employees) and innovation by developing superior products and thus into the increase of the organization’s performance. Benefits in the area of organization processes arising from knowledge continuity ensuring the quality adaptation of worker are further shown in Figure 6).

**Fig. 6: Benefits arising from the ensuring of knowledge continuity management in business processes the quality adaptation of worker**

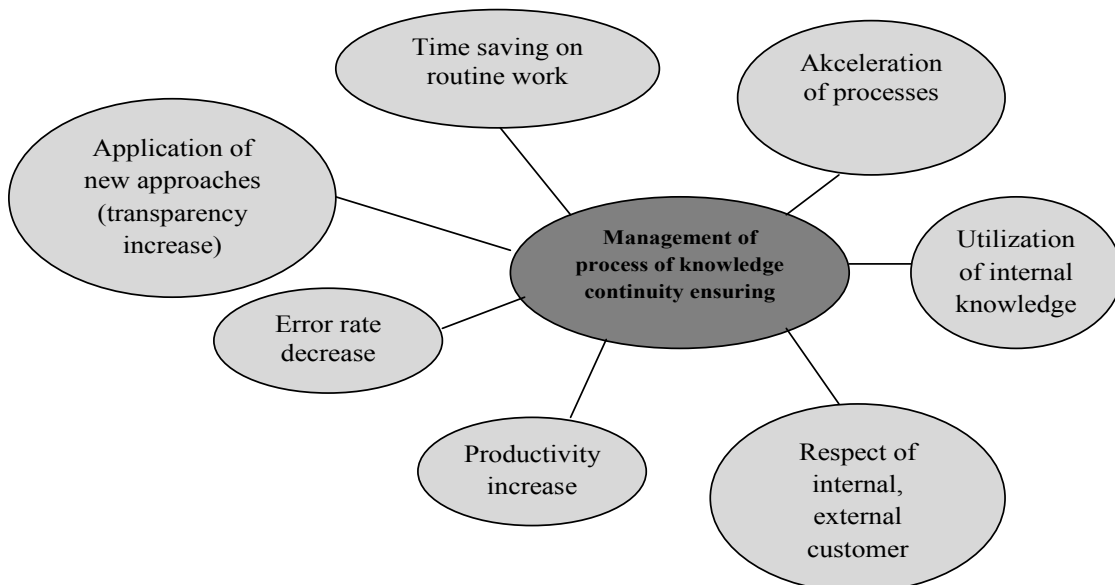

Source: Author

The enhancement of quality of processes by means of ensuring knowledge continuity can be achieved by organizations in the following ways:

- By identifying key employees with critical knowledge pursuant to decision-making situations (transfer of structured knowledge followed by the transfer of critical knowledge, which will project in the quality of decision-making)
- By a suitable personnel policy; it is in particular important to make sure that employees who are carriers of critical knowledge do not leave before they transfer the critical knowledge to a suitable successor (at the time when the employee leaves, the organization should already have a successor who has the same critical knowledge necessary for his work as his predecessor)
- By continuous transfer of knowledge that must be ensured during the professional history of employees and not only at the time when they are about to leave the organization
- By developing a high-quality organizational culture in terms of natural knowledge sharing and transfer and idea brainstorming => the necessity of anchoring the area of knowledge continuity ensuring in the organizational culture of codes of conduct that have to be binding on an organization's employee and into the system of shared values (integration values) that maintain, strengthen and improve the compactness of the organization and its processes (ensure integrity), improve process efficiency as they shorten links (distances) between individual elements
- By creating systems of gradual enhancement of quality of processes
- By deliberate establishment of a suitable organizational climate
- By setting a suitable organizational structure encouraging communication among employees; the personality of the manager responsible at the given level for adequate adherence to efficient measures of knowledge continuity ensuring.

=> in case the conditions leading to knowledge continuity ensuring are not met, it will lead to the raising of barriers to knowledge sharing and transfer and the key processes in organizations will not work appropriately.

## **Conclusion**

Based on the results it is possible to state that knowledge continuity ensuring has a significant meaning for and impact on the quality of processes and the quality of operational, tactical and strategic decision-making based on timely, precise and complex knowledge of the matter in question. The importance of knowledge continuity ensuring also follows from the fact that a leaving employee in an organization where knowledge continuity is not ensured will carry away not only the know-how, but also relationships s/he has established with his/her collaborators in the organization. Where knowledge continuity is ensured, if an employee with critical knowledge decides to leave, the organization will not lose the knowledge since it has been transferred to a different employee. Also the quality of organizational processes

will be preserved. Systematic knowledge continuity ensuring is therefore aimed at the continuity of decision-making and an organization's development.

## Acknowledgement

This contribution is a follow-up to the project of University – wide internal grant agency (CIGA), number 20121001 – Business continuity management contributing to higher performance in organizations.

## References

- [1] BEAZLEY, H., BOENISCH, J., HARDEN, D. *Continuity Management: Preserving Corporate Knowledge and Productivity When Employees Leave*. 2002, John Wiley & Sons, New York, ISBN 978-0471219064.
- [2] BEAZLEY, H. *Knowledge Continuity: The New Competitive Advantage*. [online]. 2003 [cit. 2008-07-07]. Available at: <<http://www.gwsae.org/executiveupdate/2003/April/knowledge.htm>>.
- [3] BEAZLEY, H., BOENISCH, J., HARDEN, D. Knowledge Continuity: The New Management Function. *Journal of Organizational Excellence*, 2003, Vol. 22, No. 3, pp. 65-81, ISSN 0953-4814.
- [4] Business Continuity Institute. *BCI* [online]. 2010 [cit. 2010-06-11]. Available at: <<http://www.thebci.org/>>.
- [5] BRATIANU, C. *A dynamic structure of the organizational intellectual capital*. In: Naaranoja, M. Knowledge management in organizations, 2008, pp. 233-243, ISSN 1479-4411.
- [6] CABRERA, A., COLLINS, W., SALGADO, J. S., Determinants of Individual Engagement in Knowledge sharing. *International Journal of Human Resource Management*, 2006, Vol. 17 (2), pp. 254-264, ISSN 0958-5192.
- [7] British Standards Institution. *BS 25999 Business continuity* [online]. 2010 [cit. 2010-06-11] BSI Group. Available at: <<http://www.bsigroup.com/en/Assessment-and-certification-services/management-systems/Standards-and-Schemes/BS-25999/>>.
- [8] GOLDRATT, E. M. *Isn't It Obvious?* North River Press, 2009, ISBN 978-0884271925.
- [9] JOHANNESSEN, J., OLSEN, B. Knowledge Management and Sustainable Competitive Advantages: The Impact of Dynamic Contextual Training, *International Journal of Information Management*, 2003, Vol. 23 (4), pp. 277-289, ISSN 0268-4012.
- [10] JONES, R. Measuring the benefits of knowledge management at the Financial Services Authority: a case study. *Journal of Information Science*, 2003, Vol. 29, Issue 6, pp. 475-487, ISSN 0165-5515.
- [11] LEVY, M. Knowledge retention: minimizing organizational business loss. *Journal of Knowledge Management*, 2011, Vol. 15, Issue 4, pp. 582-600, ISSN 1367-3270.

- [12] MASSINGHAM, P. Knowledge risk management: a framework. *Journal of Knowledge Management*, 2010, Vol. 14, Issue 3, ISSN 1367-3270.
- [13] MÜNSTERMANN, B., ECKHARDT, A., WEITZEL, T. The performance impact of business process standardization: An empiric evaluation of the recruitment process. *Business Process Management Journal*, 2010, Vol. 16, Issue 1, ISSN 1463-7154.
- [14] NONAKA I., TAKEUCHI, H. *The Knowledge-Creating Company*, Oxford University Press, 1995, New York, NY, ISBN
- [15] NORTH, K., HORNUNG, T. The benefits of Knowledge Management - Results of the German Award "Knowledge Manager 2002". *Journal of Universal Computer Science*, 2003, Vol. 9, issue 6, pp. 463-471. Springer. New York, 2003, ISSN 0948-695X.
- [16] PETŘÍK, T. *Procesní a hodnotové řízení firem a organizací – nákladová technika a komplexní manažerská metoda ABC/ABM*. Linde Praha, a. s., 2007, ISBN 978-80-7201-648-8.
- [17] ŘEPA, V. *Podnikové procesy – procesní řízení a modelování*. Praha: Grada Publishing, a. s, 2006, pp. 265, ISBN 80-247-1281-4.
- [18] STAM, CH. *Knowledge and the Ageing Employee: A Research Agenda*. INHOLLAND University of Applied Sciences, 2009, Haarlem, The Netherlands. ISBN 978-1-906638-71-9.
- [19] WONG N. W. Strategic skills of business continuity managers: Putting business continuity management into corporate long range planning. *Journal of Business Continuity & Emergency Planning*, Henry Stewart Publications, 2009, Vol. 4, No. 1, pp. 62–68, ISSN 1749–9216.

## Contact Address

### **Ing. Hana Urbancová, Ph.D.**

Czech University of Life Sciences, Faculty of Economics and Management,  
 Department of Management  
 Kamýcká 129, 165 21, Prague 6 – Suchdol, Czech Republic  
 Email: urbancova@pef.czu.cz  
 Phone number: +420 224 382 026

### **Ing. Josef Kříž, CSc.**

Czech University of Life Sciences, Faculty of Economics and Management,  
 Department of Management  
 Kamýcká 129, 165 21, Prague 6 – Suchdol, Czech Republic  
 Email: krizj@pef.czu.cz  
 Phone number: +420 224 382 383

Received: 30. 01. 2012

Reviewed: 20. 08. 2012

Approved for publication: 01. 11. 2012



# GUIDELINES FOR PAPER WRITING

## Scientific Papers of the University of Pardubice. Series D, Faculty of Economics and Administration

### GENERAL INFORMATION

By sending an article, the author agrees that the article is original and unpublished. The author agrees with the on-line publication of the contribution as well. All the papers must follow the format guidelines. Decision about acceptance of article for publication is based on anonymous peer review report.

### FORMAL REQUIREMENTS

#### Language

Papers can be written in Czech, Slovak or English language according to the calls of contribution submission. In the case of contribution submission written in English, the statement about the quality of English language is required.

#### Paper Structure

Title. Author. Abstract (150 – 200 words). Keywords (5 – 7 keywords). Codes of JEL Classification ([http://www.aeaweb.org/jel/jel\\_class\\_system.php](http://www.aeaweb.org/jel/jel_class_system.php)). Introduction. 1 Statement of a problem. 2 Methods. 3 Problem solving. 4 Discussion. Conclusion. Acknowledgement. References. Contact Address. For writing your article please use predefined template styles and formats. The structure of the article is required.

#### Main Text Format

The article should not be longer than min. 8 and max. 12 pages format A4. The paper should be written in MS Word, font Times New Roman 13, line spacing 1, spacing after heading and paragraphs is 6 mm, justified alignment. All margins are set to 2.5 on the left and right, top and down edge 2. Header 1.25 and footer to 1.6. If necessary, use bold, do not use underline and italics. Paragraph indentation is 6 mm. Do not use the numbering of pages.

#### Headings

**1 Chapter (Times New Roman, 14, bold)**

**1.1 Sub-chapter (Times New Roman, 13, bold)**

**1.1.1 Sub-sub-chapter (Times New Roman, 13, bold italics)**

#### Tables and Figures

Tables and pictures are placed directly in the text. Figure is any graphical object other than table. Figures – we recommend choosing two-dimensional graphs, only in cases of inevitable spatial graphs. Lines, axes and a description of the image are written in font size 9. We recommend not using the raster grid and outer surround. Journal is printed in black and white. The source is placed right below the figure or table, Times New Roman, italics, 11.

Marking tables: **Tab. 1: Title in italics, bold, 13**, placed above the table, an explanation of abbreviations used in the note below the table. Tab. 1, Tab. 2 in the text. Example:

**Tab. 1: Title of the table**

Number	Year 2001	Year 2002	Year 2003
1	23	25	23
2	24	25	24

Source of data: [1]

Marking figures: **Fig. 1: Title in italics, bold, 13**, located above the figure. Fig. 1, Fig. 2 in the text of article. Example:

**Fig. 1: Title of the figure**



Source of data: [1]

### **Formulas**

Formulas are to be numbered. The number should be written in font size 13 Times New Roman in parentheses, aligned to the right margin and next to the formula.

### **Citation in the Text**

Literature reference should be presented in the text in its respective place with an indication number in square parentheses: [1]. If necessary, use [1, p. 24].

### **Footnotes**

Footnotes should be used sparingly. Do not use footnotes for citing references

### **Acknowledgement**

In the case, the paper presents the result of the grant project, an acknowledgement should be there (e.g. The paper was supported by GA ČR No. 111/111/111 “Title of the project”).

### **References**

References to literature should be presented according to ISO 690 (01 0197). Sources are sorted alphabetically. Numbers are in square brackets, font Times New Roman, size 13 pt, indent 1 cm, space 6 points. List of multiple publications from one author must be listed in order of date of issue. If one title has more authors, initiate maximally three. If one or more names are missed attach to the last mentioned name abbreviation "et al." or its Czech equivalent of “a kol.”. Example:

### **References (Times New Roman, 13 points, bold, alignment left, a gap of 6 points)**

- [1] BELODEAU, B., RIGBY, D. *Management Tools and Trends 2009*. Bain&Company. [cit. 2010-02-25]. Available at WWW: Available from WWW: <[http://www.bain.com/bainweb/PDFs/cms/Public/Management\\_Tools\\_2009.pdf](http://www.bain.com/bainweb/PDFs/cms/Public/Management_Tools_2009.pdf)>.
- [2] BERGEVOET, R. H. M., ONDERSTEIJN, C. J. M., SAATKAMP, H. W., VAN WOERKUM, C. M. J., HUIRNE, R. B. M. Entrepreneurial behavior of Dutch dairy farmers under a milk quota system: goals, objectives and attitudes. *In Agricultural Systems*, 2004, Vol. 80, Iss.1, pp. 1-21. ISSN: 0308-521X.

- [3] GREENACRE, M. *Correspondence Analysis in Practice*. Boca Raton: Chapman & Hall/CRC, 2007. 280 p. ISBN 978-1-58488-616-7.

**Contact Address (Times New Roman, 13 points, bold, alignment left, a gap of 6 points)**

**prof. Ing. Jan Novák, CSc.**

University of Pardubice, Faculty of Economics and Administration

Studentská 84, 532 10 Pardubice, Czech Republic

Email: Jan.Novak@upce.cz

Phone number: +420 466 036 000

**Paper submission**

Please send your paper in electronic form MS Word via e-mail to Martina.Kynclova@upce.cz

**REVIEW PROCEDURE**

At first, each submission is assessed by executive editor and by The Editorial Board, who check whether the submission satisfies the journal requirements. If it does, they send the papers to the referees. Referees elaborate evaluation reports in the form of a standard blank form (sent to referees by the executive editor). Referees evaluate the papers from content and formal point of view, a summary of comments for the author(s) is included. The referee recommendation to the editor should be one of the following: Accept for publication, accept with minor revisions, accept with major revisions, reject. The Editorial Board reserves the right to return to the authors any manuscript that in their opinion is not suitable for publication in the journal, without expressly stipulating the reasons for doing so. Accepted articles for publication do not undergo linguistic proofreading. Executive editor informs the author about the result of the review procedure.

**EDITORIAL BOARD**

**Assoc. Prof. Ing. et Ing. Renáta Myšková, Ph.D.**, Senior Editor, Faculty of Economics and Administration, University of Pardubice, Dean

**prof. Ing. Jan Čapek, CSc.**, Faculty of Economics and Administration, University of Pardubice

**Assoc. Prof. Ing. Iлона Obršálová, CSc.**, Faculty of Economics and Administration, University of Pardubice

**Prof. Ing. Vladimír Olej, CSc.**, Faculty of Economics and Administration, University of Pardubice

**Prof. RNDr. Bohuslav Sekerka, CSc.**, Faculty of Economics and Administration, University of Pardubice

**Ing. Karel Šatera, Ph.D. MBA**, Faculty of Economics and Administration, University of Pardubice

**Ing. Martina Kynclová**, Executive Editor, Faculty of Economics and Administration, University of Pardubice

## SCIENTIFIC BOARD

**Dr. John Anchor**, University of Huddersfield, England

**Assoc. Prof. Ing. Josef Brčák, CSc.**, Czech University of Life Sciences Prague, Faculty of Economics and Management, Czech Republic

**Prof. Ing. Jiří Dvořák, DrSc.**, University of Technology Brno, Faculty of Business and Management, Czech Republic

**Assoc. Prof. Ing. Peter Fabian, CSc.**, The University of Žilina, Slovak Republic

**Assoc. Prof. Ing. Alžběta Foltínová, CSc.**, University of Economics Bratislava, Slovak Republic

**Assoc. Prof. Ing. Mojmír Helísek, CSc.**, The University of Finance and Administration Prague, Czech Republic

**Prof. Ing. Ivan Jáč, CSc.**, Technical university of Liberec, Faculty of Economics, Czech Republic

**Prof. Ing. Christiana Kliková, CSc.**, Technical University of Ostrava, Faculty of Economics, Czech Republic

**Prof. JUDr. Jozef Králik, CSc.**, Police Academy Bratislava, Slovak Republic

**Prof. Ing. Miroslav Krč, CSc.**, University of Defence Brno, Czech Republic

**Prof. PhDr. Karel Lacina, DrSc.**, Czech University of Life Sciences Prague, Czech Republic

**Assoc. Prof. Ing. Ivana Linkeová, Ph.D.**, Czech Technical University in Prague, Faculty of Mechanical Engineering, Czech Republic

**Assoc. Prof. JUDr. Eleonóra Marišová, Ph.D.**, Slovak University of Agricultural in Nitra, Faculty of European Studies and Regional Development, Slovak Republic

**Prof. Dr. Ing. Miroslav Pokorný**, Technical University of Ostrava, Czech Republic

**Prof. Ing. Jiří Polách, CSc.**, Business School Ostrava, Czech Republic

**Prof. Ligita Šimanskienė, doctor of social sciences**, Klaipėda University, Lithuania

**Prof. univ. Dr. Angela Repanovici**, Universitatea Transylvania Brasov, Romania

**Assoc. Prof. Ing. Elena Šúbertová, Ph.D.**, University of Economics Bratislava, Faculty of Business Management, Slovak Republic

**Assoc. Prof. Ing. Miloš Vítek, CSc.**, Czech Republic

## CONTACT US

University of Pardubice

Faculty of Economics and Administration

Studentská 95, 532 10 Pardubice, Czech Republic

Email: [martina.kynclova@upce.cz](mailto:martina.kynclova@upce.cz)

[www.uni-pardubice.cz](http://www.uni-pardubice.cz)

## Journal web page:

<http://www.upce.cz/en/fes/veda-vyzkum/fakultni-casopisy/scipap.html>

Title	Scientific Papers of the University of Pardubice, Series D
Publisher	University of Pardubice Faculty of Economics and Administration Studentská 95, 532 10 Pardubice, Czech Republic
Registration number	IČ 00216275
Editor-in-chief	Mgr. Eva Matějová
Periodicity	3 per year
Volume number	18
Issue number	24 (2/2012)
Place	Pardubice
Publication Date	26. 11. 2012
Number of Pages	227
Number of Copies	75
Edition	First
Printed by	Printing Centre of the University of Pardubice

MK ČR E 19548  
ISSN 1211-555X (Print)  
ISSN 1804-8048 (Online)

